

Grant QR2 Range

Indirect Heat Pump Cylinder

Installation, Servicing and User Instructions

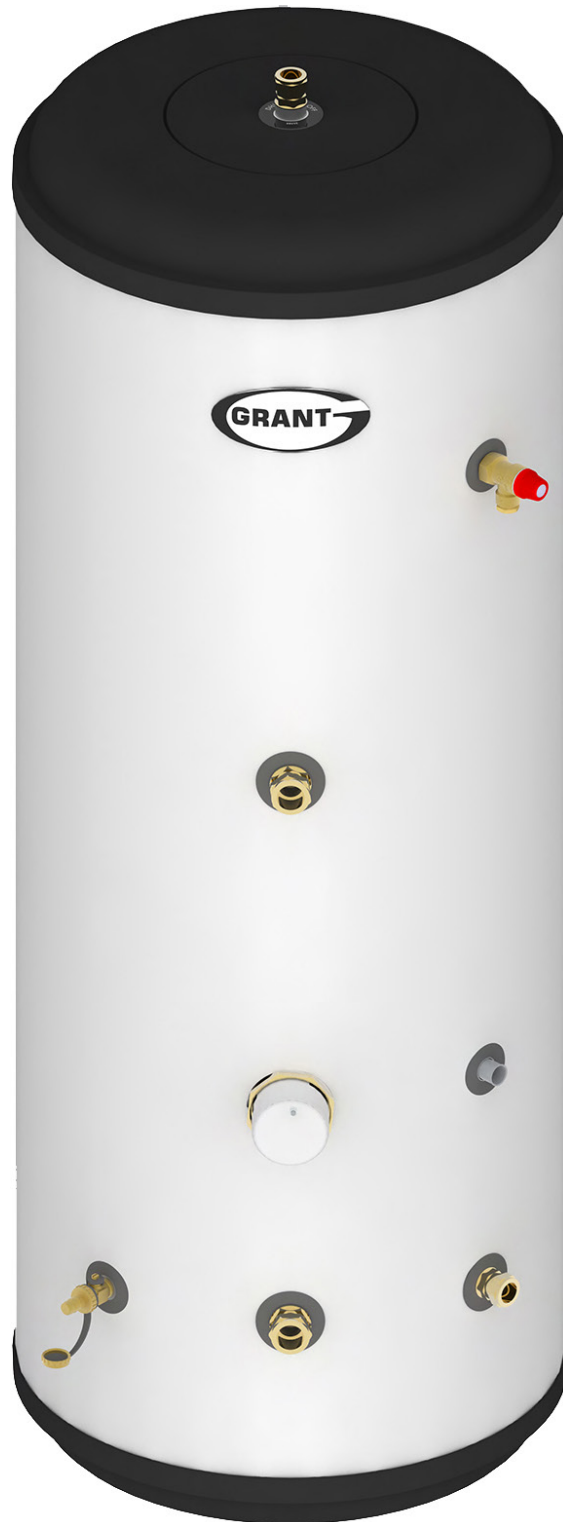

IMPORTANT NOTE FOR INSTALLERS

These instructions are intended to guide Installers on the installation, commissioning and servicing of a Grant Quick Recovery indirect Heat Pump cylinder. After installing the cylinder, leave these instructions with the user.

User instructions to guide users in the operation of the cylinder are in Section 12 of these instructions.

SPECIAL TEXT FORMATS

The following special text formats are used in these instructions for the purposes listed below:

! WARNING !

Warning of possible human injury as a consequence of not following the instructions in the warning.

! CAUTION !

Caution concerning likely damage to equipment or tools as a consequence of not following the instructions in the caution.

! NOTE !

Used for emphasis or information not directly concerned with the surrounding text but of importance to the reader.

PRODUCT CODES COVERED

Grant QR2 Single Coil Heat Pump Cylinder Model	Product Code
150 litre	QR2SC150
180 litre	QR2SC180
210 litre	QR2SC210
250 litre	QR2SC250
300 litre	QR2SC300

Grant Slimline QR2 Single Coil Heat Pump Cylinder Model	Product Code
150 litre	QR2SC150SL
180 litre	QR2SC180SL
210 litre	QR2SC210SL

SERVICING

The cylinder should be serviced at least every twelve months and the details entered in the Service Log in Appendix A at the back of these instructions.

CUSTOMER SUPPORT CENTRE

Grant UK provides an online support centre for Heating Professionals and Homeowners to access post-installation care, advice and maintenance support for Grant products. Follow the QR codes below to access your relevant Customer Support Centre.



Homeowner



Professional



GRANT ENGINEERING (UK) LIMITED

Frankland Road, Blagrove Industrial Estate, Swindon, SN5 8YG

Tel: +44 (0)1380 736920 Fax: +44 (0)1380 736991

Email: info@grantuk.com www.grantuk.com

This manual is accurate at the date of printing but will be superseded and should be disregarded if specifications and/or appearances are changed in the interests of continued product improvement. However, no responsibility of any kind for any injury, death, loss, damage or delay however caused resulting from the use of this manual can be accepted by Grant Engineering (UK) Limited, the author or others involved in its publication.

All goods sold are subject to our official Conditions of Sale, a copy of which may be obtained on application.

© Grant Engineering (UK) Limited. No part of this manual may be reproduced by any means without prior written consent.

CONTENTS

1	INTRODUCTION	4	8	FAULT FINDING	28
1.1	Installation Requirements	4	8.1	intermittent Water Discharge	28
1.2	Water Supply Requirements	4	8.2	Constant Water Discharge	28
1.3	Location	4	8.3	No Flow From Hot Water Taps	29
1.4	Storage and Handling	4	8.4	Cold Water Flow From Hot Water Taps	29
1.5	About Your Cylinder	4	8.5	Excessive Hot Water From Taps	30
1.6	Open Vented Hot Water Systems	4	9	SPARE PARTS	31
1.7	Primary Circuit Pipework Connections	4	9.1	Spare Parts	31
1.8	Secondary Circuit Pipework Connections	4	10	PRODUCT FICHE	32
1.9	Taps and Fittings	4	11	END OF LIFE INFORMATION	32
1.10	Hard Water Scaling	5	12	USER INSTRUCTIONS	33
1.11	Insulation	5	12.1	User Instructions	33
1.12	Health and Safety	5	13	GUARANTEE	34
2	TECHNICAL DATA	6		APPENDIX A - INSTALLATION, COMMISSIONING AND SERVICE RECORD LOG BOOK	36
2.1	Cylinder Technical Data	6			
2.2	Product Contents	8			
2.3	Dimensions	9			
2.4	Connections and Controls	12			
2.5	Optional Quick Recovery Cylinder Plinth Dimensions	13			
3	PRIMARY CIRCUIT INSTALLATION	15			
3.1	Grant QR2 Indirect Heat Pump Cylinders	15			
3.2	Primary Connections	15			
3.3	The 2-Port Valve	15			
3.4	Hard Water Areas	15			
4	SECONDARY CIRCUIT INSTALLATION	16			
4.1	General	16			
4.2	Cold Water Inlet Manifold	16			
4.3	Installation	16			
4.4	Expansion Vessel	17			
4.5	Temperature and Pressure Relief Valve	17			
4.6	Hot Water Supply	17			
4.7	Prevention of Scalding	17			
4.8	Secondary Return	17			
4.9	Tundish	18			
4.10	Discharge Pipe	18			
4.11	Discharge Pipe Sizing	18			
4.12	Worked Example	18			
4.13	Discharge Pipe Arrangement	19			
5	ELECTRICAL	20			
5.1	Immersion Heater	20			
5.2	Immersion Heater Wiring Instructions	20			
5.3	Immersion Heater Safety Cut-Out	21			
5.4	Dual Thermostat	21			
5.5	2-Port Valves	21			
5.6	Heat Pump Interface Box	21			
5.7	Wiring Diagrams	22			
6	COMMISSIONING, DRAINING DOWN AND SAFETY	25			
6.1	Filling the Cylinder	25			
6.2	Draining Down	25			
6.3	Immersion Heater Safety Cut-Out	25			
6.4	Cold Water Discharge from Tundish	26			
6.5	Hot Water Discharge from Tundish	26			
6.6	Expansion Vessel	26			
6.7	Customer Handover	26			
7	MAINTENANCE	27			
7.1	Servicing and Maintenance	27			
7.2	Inlet Manifold Assembly	27			
7.3	Expansion relief Valve	27			
7.4	Expansion Vessel	27			

1 INTRODUCTION

1.1 INSTALLATION REQUIREMENTS

Thank you for purchasing a Grant unvented hot water storage cylinder from our QR2 range.

This cylinder conforms to the requirements of BS EN 12897:2016+A1:2020. Water supply - specification for indirectly heated unvented (closed) storage water heaters.

These Installation and User instructions must be read carefully before you begin installing the cylinder.

The cylinder must be installed by a competent person in compliance with all current legislation, codes of practice and local by-laws covering the installation of an unvented hot water cylinder.

Please also make sure that the installation complies with the information contained in these Installation and User Instructions.

To prevent damage to the coil/s, cylinder and cylinder connections, make any soldered joints before connecting pipework to the cylinder.

1.2 WATER SUPPLY REQUIREMENTS

We recommend that your Grant unvented cylinder is installed with an uninterrupted water supply.

Where possible, the unit should be fed via a Ø22 mm supply pipe. It requires a supply pressure of at least 1.5 bar with a flow rate of at least 25 litres per minute as a minimum for it to function.

Even with this pressure and flow rate, the flow from the outlets will be disappointing if several outlets are used simultaneously. Generally speaking, the higher the supply pressure, the better the system will function.

The inlet manifold pressure reducing valve is factory set to limit the incoming system operating pressure to 3 bar. The maximum supply pressure into the pressure reducing valve (PRV) is 12 bar.

1.3 LOCATION

The unit is designed to be floor standing, vertically mounted, internally in a frost-free environment. When choosing a suitable location for the cylinder, consideration should be given to the routing of the discharge pipe to a convenient point and also the availability of an adequate power supply for connecting the immersion heater.

The cylinder may stand on any flat and level surface without any special foundation requirements, provided that it is sufficiently robust to support the full weight of the cylinder (refer to Section 2.1).

The position of the cylinder should be such that easy access is provided for servicing the controls and replacing the immersion heater(s) should the need arise.

Generally, pipe runs should be made as short as possible and insulated to prevent heat loss.

Should it be required, a stand for the cylinder is available to purchase from Grant UK (product code: MB-29) to enable pipework to be run underneath the cylinder with ease. Refer to Section 2.5 for dimensions.

1.4 STORAGE AND HANDLING

If the cylinder is not being installed immediately, it should remain in its carton to prevent damage. We recommend that the cylinder be transported to its installation position on a sack truck or similar whilst still within the carton.

! CAUTION !

Do not use the factory fitted Temperature and Pressure relief valve (T&P relief valve) as a handle when moving and positioning the cylinder.

1.5 ABOUT YOUR CYLINDER

Grant QR2 indirect Heat Pump cylinders have either:

- A single indirect coil designed for connection to an air source heat pump, such as the Grant AERONA range. If another heat source, such as a boiler or another make of heat pump is to be connected, please refer to the manufacturer's installation instructions for more information.

The heat pump coil may need to be connected using a 2-port motorised valve (refer to Section 3.3 for further details). This valve is supplied loose with all Grant QR2 indirect heat pump cylinders.

Failure to fit this 2-port valve in a system layout where it is required (refer to Section 3.3 for further details) will invalidate all guarantees and will be in breach of the Building Regulations Approved Document G3 (2010). More information on electrical wiring is given in Section 5 of these instructions.

Grant QR2 cylinders are factory-fitted with a temperature and pressure relief (T&P) valve and a 3 kW electric immersion heater.

Refer to Figure 2-3 and table 2-10 for the T&P valve position.

Refer to Sections 5, 6 and 12 for further details on immersion heaters.

1.6 OPEN VENTED HOT WATER SYSTEMS

If required, your Grant QR2 indirect Heat Pump cylinder can be used as part of an open vented hot water system, i.e. fed from a cold water storage cistern and fitted with an open vent pipe, provided the maximum head does not exceed 30 metres.

When used in this way, it will not be necessary to install the expansion vessel and cold water inlet manifold supplied with the cylinder.

! NOTE !

The temperature and pressure relief (T&P) valve must be left connected to the cylinder (as supplied).

As it may still operate due to temperature, the temperature and pressure relief (T&P) valve should be connected in the correct manner - refer to guidance given in Section 4 of these instructions.

1.7 PRIMARY CIRCUIT PIPEWORK CONNECTIONS

All primary circuit pipework connections to the cylinder MUST be made in accordance with Figure 2-3. Refer to Section 3 (Primary Circuit Installation) for further details.

1.8 SECONDARY CIRCUIT PIPEWORK CONNECTIONS

All secondary circuit primary pipework connections to the cylinder MUST be made in accordance with Figure 2-3. Refer to Section 4 (Secondary Circuit Installation).

1.9 TAPS AND FITTINGS

All taps and fittings incorporated in the unvented hot water system should have a rated operating pressure of 7 bar or above.

The compression nuts and olives required to make all necessary pipework connections to the cylinder are supplied fitted.

1.10 HARD WATER SCALING

If the cylinder is used in a hard water area scaling will form inside the cylinder and this will reduce both the performance and working life of the cylinder.

Where the total hardness exceeds 125 ppm a high capacity water softener, or suitable water conditioner, should be installed in the incoming cold water supply to the cylinder.

The cylinder immersion heater control thermostat has been factory-set to around 61.5 °C(±3 °C). Please refer to Section 5.1 for further information on the immersion heater supplied.

The water temperature control thermostats (on the immersion heaters and dual thermostats) fitted to the cylinder should be set no higher than 65 °C, however this could be decreased to be between 60 °C and 65 °C depending on the end user's requirements.

Setting a lower target temperature will help to minimise the build-up of lime scale and is likely to increase the longevity of the hot water cylinder.

1.11 INSULATION

All Grant QR2 indirect Heat Pump cylinders are insulated with a 50 mm layer of CFC/HCFC free, fire retardant, polyurethane foam injected between the stainless steel cylinder and the outer casing. This polyurethane foam has a Global Warming Potential (GWP) of 3.1 and an Ozone Depletion Potential (ODP) of 0.

1.12 HEALTH AND SAFETY

The information supplied in Tables 2-2 to 2-3 will help you assess the safest way to manoeuvre your cylinder into position.

Please use the correct table to find the empty weight of your cylinder and then consider how you can safely move it into its final position.

Please leave these Installation and User Instructions with the householder after installation.

2 TECHNICAL DATA

2.1 CYLINDER TECHNICAL DATA

Table 2-1: Cylinder technical data (All models)

	Grant QR2 Indirect Cylinders
Secondary return connection (mm)	22 (250 L & 300 L only)
Cold feed / hot draw-off connections (mm)	22
Primary coil connections (mm)	22
Maximum water supply pressure (bar)	12
System operating pressure - pre-set (bar)	3
Expansion vessel charge pressure (bar)	3
Expansion relief valve pressure (bar)	6
T&P relief valve lift pressure (bar)	7
T&P relief valve lift temperature (°C)	90
Maximum primary circuit working pressure (bar)	2.5

2.1.1 SINGLE COIL MODELS

Table 2-2: Cylinder technical data (QR2SC models)

	Grant QR2 Single Coil Indirect HP Cylinders				
	150 litre	180 litre	210 litre	250 litre	300 litre
Nominal capacity (litres)	150	180	210	250	300
Actual capacity (litres)	135	168	200	238	281
Overall diameter (mm)	561	561	561	561	561
Overall height (mm)	1175	1354	1541	1792	2103
Weight - empty (kg)	36.5	39	44	49	54.5
Coil capacity (litres)	11	11	11	11	11
Total weight full - incl coil (kg)**	182.5	218	255	298	346.5
Primary coil length (m)	18.5	18.5	18.5	18.5	18.5
Primary coil surface area (m ²)	3.2	3.2	3.2	3.2	3.2
Primary coil pipe diameter (mm)	28	28	28	28	28
Performance:					
Primary coil rating (kW)	44.70	42.14	39.58	36.17	31.90
Standing heat loss (kWh/24hrs)*	1.15	1.21	1.41	1.54	1.81
Standing heat loss (W)*	48	50	59	64	75
ERP rating	B	B	B	B	C

* Test carried out at 60 °C.

**Total weight full = Weight empty + Actual capacity + Coil capacity.

Table 2-3: Cylinder technical data (QR2SCSL models)

	Grant QR2 Slimline Single Coil Indirect HP Cylinders		
	150 litre	180 litre	210 litre
Nominal capacity (litres)	150	180	210
Actual Capacity (litres)	140	170	200
Overall diameter (mm)	481	481	481
Overall height (mm)	1567	1839	2110
Weight - empty (kg)	37	44	49
Coil capacity (litres)	11	11	11
Total weight full - incl coil (kg)**	188	225	260
Primary coil length (m)	18.5	18.5	18.5
Primary coil surface area (m ²)	3.2	3.2	3.2
Primary coil pipe diameter (mm)	28	28	28
Performance:			
Primary coil rating (kW)	37.50	36.55	35.60
Standing heat loss (kWh/24hrs)*	1.24	1.40	1.57
Standing heat loss (W)*	52	58	65
ERP rating	B	B	C

* Test carried out at 60 °C.

**Total weight full = Weight empty + Actual capacity + Coil capacity.

2.2 PRODUCT CONTENTS

2.2.1 SINGLE COIL MODELS

Table 2-4: Product contents (QR2SC and QR2SCSL models)

	Grant QR2 Single Coil indirect HP Cylinders				
	150 litre	180 litre	210 litre	250 litre	300 litre
Cylinder assembly	1	1	1	1	1
Expansion vessel - 18 litre (G3/4" M)	1	1	1	1	-
Expansion vessel - 25 litre (G3/4" M)	-	-	-	-	1
½" Temperature and PRV - 7 bar/90 °C - 15 mm compression fitting (Factory-fitted)	1	1	1	1	1
Tundish - 15/22 mm	1	1	1	1	1
22mm compression nut and olive (Factory-fitted)	4	4	4	5	5
¾" BSPM x 22 mm compression adapter	1	1	1	1	1
¾" BSPF x 22 mm compression adapter	1	1	1	1	1
½" Drain cock c/w hose connector (Factory-fitted)	1	1	1	1	1
Inlet manifold - 3 bar PRV and 6 bar expansion relief valve	1	1	1	1	1
2-port motorised valve - 22 mm	1	1	1	1	1
Dual thermostat (control: 25-65 °C / high limit: 90 °C)	1	1	1	1	1
Immersion heater - 3kW 1¾" boss (Factory-fitted)	1	1	1	1	1

2.3 DIMENSIONS

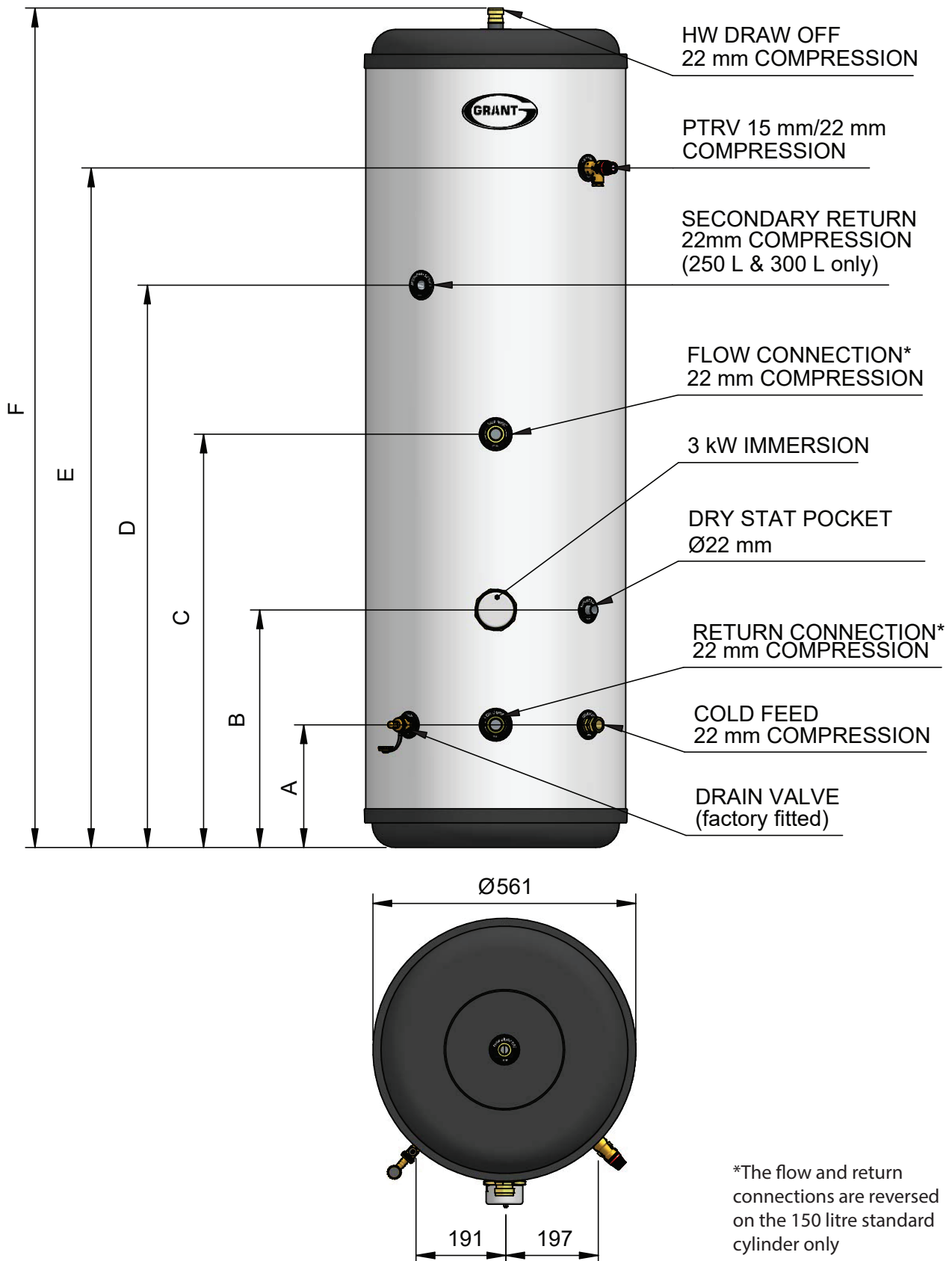

Figure 2-1: Grant QR2SC single coil Heat Pump cylinder dimensions

Table 2-5: Grant QR2SC single coil Heat Pump cylinder dimensions

Dimensions (mm)	150 litre	180 litre	210 litre	250 litre	300 litre
A	263	262	262	262	262
B	512	507	507	507	507
C	884	882	882	882	882
D	-	-	-	1200	1512
E	884	1013	1200	1450	1762
F	1175	1354	1541	1791	2103

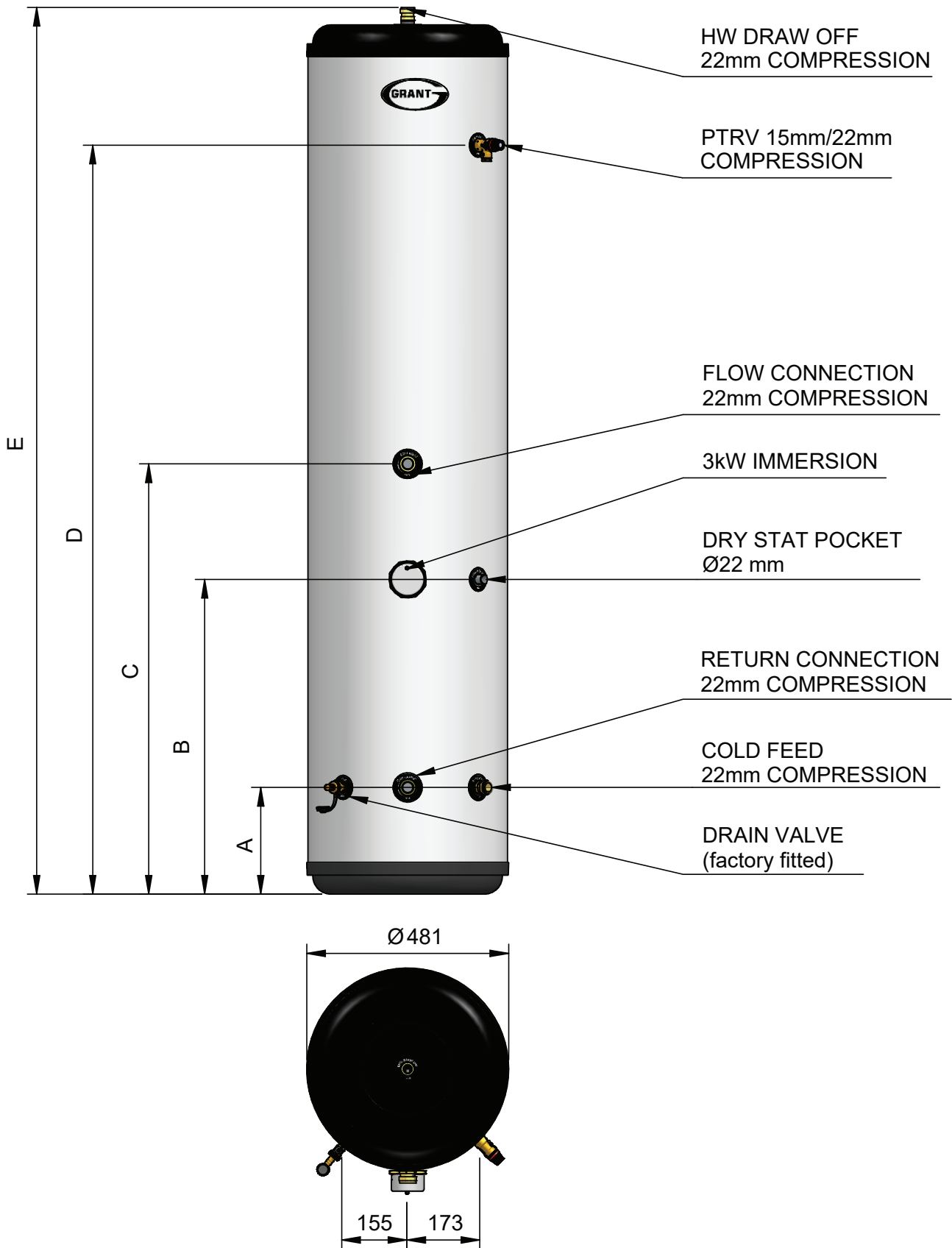

Figure 2-2: Grant Slimline QR2SCSL single coil Heat Pump cylinder dimensions

Table 2-7: Grant Slimline QR2SCSL single coil Heat Pump cylinder dimensions

Dimensions (mm)	150 litre	180 litre	210 litre
A	254	254	254
B	749	749	749
C	1024	1024	1024
D	1240	1511	1783
E	1567	1839	2110

Page intentionally left blank.

2.4 CONNECTIONS AND CONTROLS

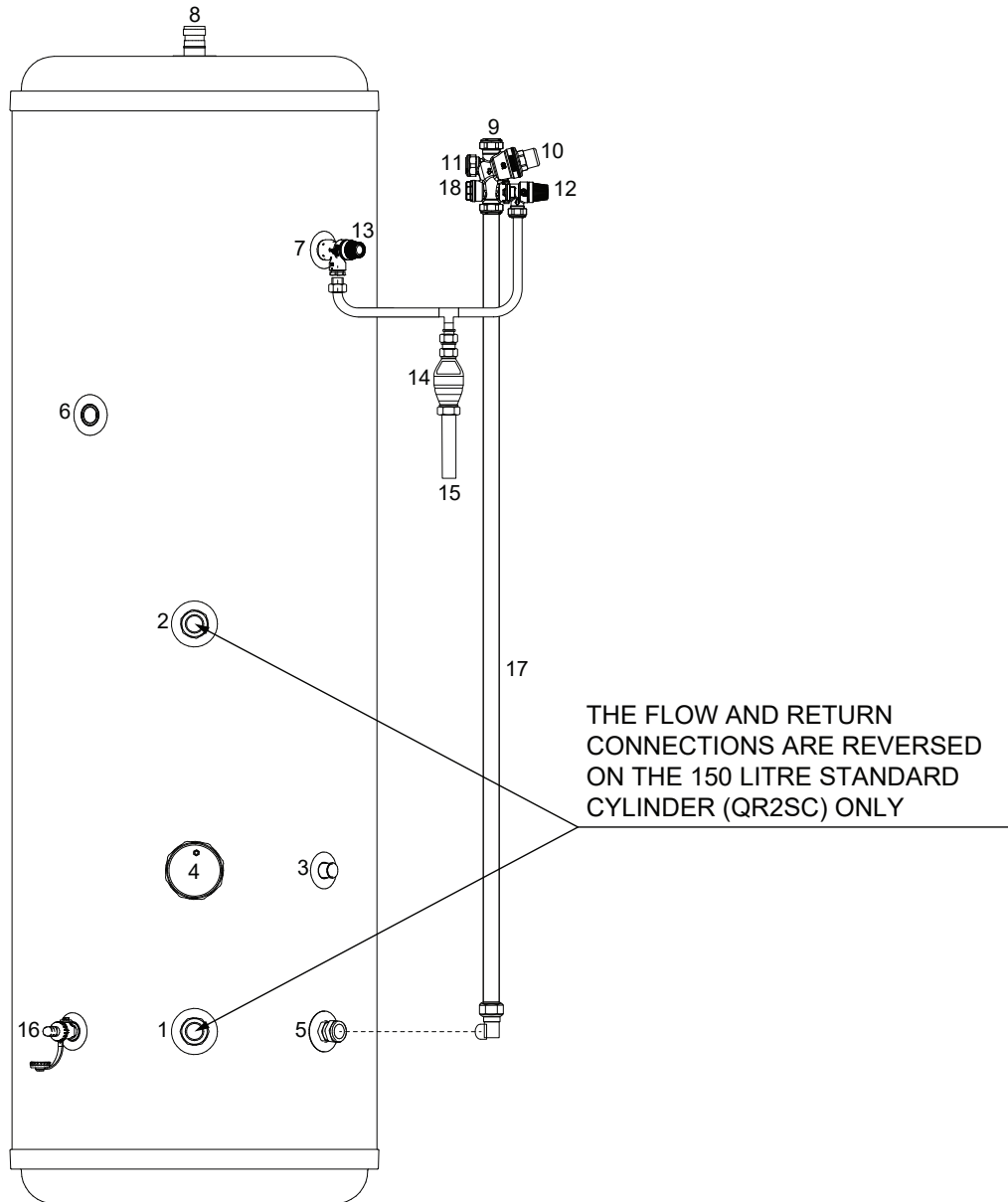

Figure 2-3: Grant QR2SC & QR2SCSL cylinders

Table 2-10: Grant QR2 indirect Heat Pump cylinder connections and controls (key to Figures 2-3)

Item	Description	Connection Size	Item	Description	Connection size
1*	Heat pump return tapping	22mm compression	10	Pressure reducing valve - 3 bar	-
2*	Heat pump flow tapping	22mm compression	11	Balanced cold supply connection	22mm compression
3	Stat pocket	20mm diameter	12***	Expansion relief valve - 6 bar	15mm compression
4	Immersion heater c/w control & limit thermostat (factory fitted)	1¼" BSP	13***	Temperature & Pressure relief valve - 90 °C / 7 bar	15mm compression
5	Cold water inlet	22mm compression	14	Tundish	15/22mm compression
6**	Secondary return	22mm compression	15	Discharge pipe (not supplied with cylinder)	-
7	T&P valve connection	½" BSPF	16	Drain cock (supplied fitted to cylinder)	½" BSPF
8	HW outlet	22mm compression	17	Mains water supply pipe (not supplied with cylinder)	-
9	CW supply to inlet manifold	22mm compression	18	Expansion vessel connection	¾" BSPF

* the flow and return connections are reversed on the 150 litre standard cylinder only

** for 250L & 300L cylinders only

*** pipework between items 12 and 13 NOT supplied with cylinder

2.5 OPTIONAL QUICK RECOVERY CYLINDER PLINTH DIMENSIONS

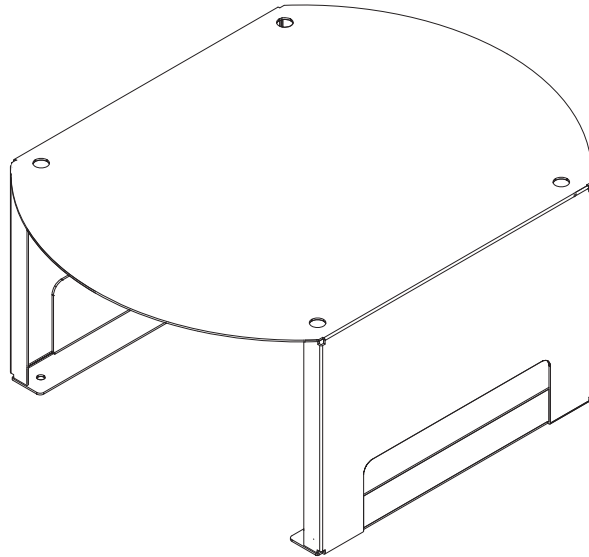

Figure 2-4: Optional quick recovery cylinder plinth (product code: MB-29)

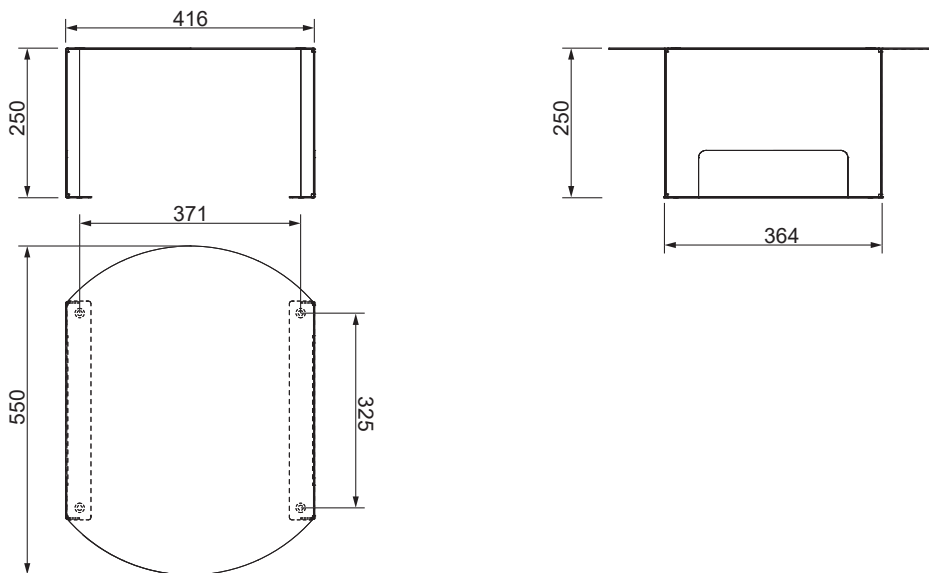

Figure 2-5: Optional quick recovery cylinder plinth dimensions

2.5.1 OPTIONAL QUICK RECOVERY CYLINDER STAND

Grant offer an optional stand for cylinders when installing an internal volumiser. Refer to figure 2.6 for dimensions and to section 1.13 for product code.

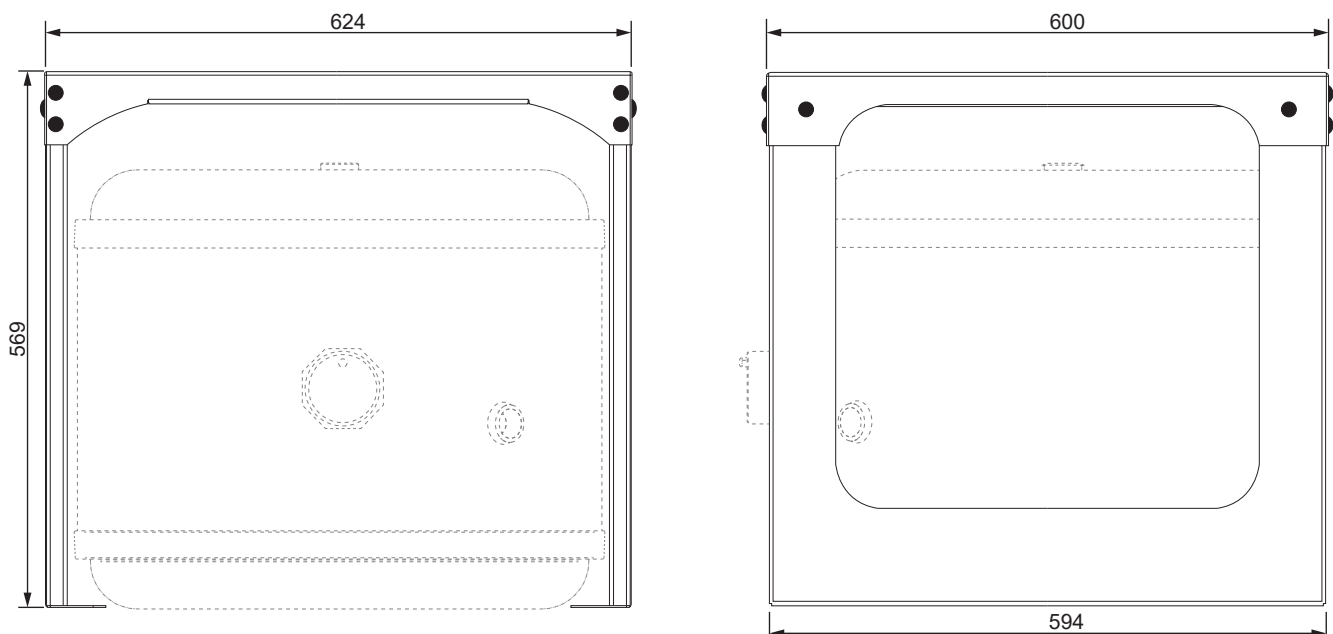

Figure 2-6: Front view dimensions - QR2 Cylinder stand for 50L internal volumiser (product code: MB-50)

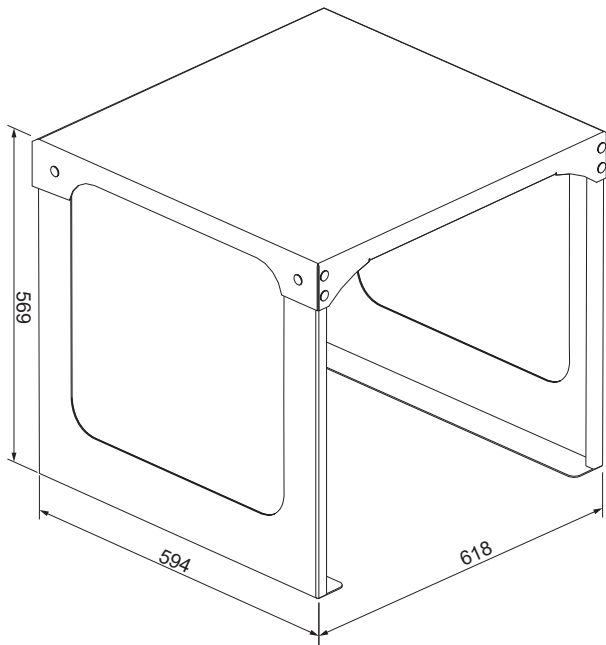

Figure 2-7: QR2 Cylinder stand for 50L internal volumiser

3 PRIMARY CIRCUIT INSTALLATION

3.1 GRANT QR2 INDIRECT HEAT PUMP CYLINDERS

Grant QR2 indirect Heat Pump cylinders are specifically designed for connection to most fully pumped Air Source Heat Pump systems (such as the Grant Aerona Heat Pump ranges) - either unvented or vented hot water systems- having a maximum working pressure of 3.5 bar and a maximum working temperature of 90°C.

If you are in any doubt over the suitability of an Air Source Heat Pump for use with the cylinder, consult the heat pump manufacturer.

! WARNING !

Solid fuel or wood burning boilers and gravity circulation systems must not be used on the primary circuit of an unvented hot water system.

3.2 PRIMARY CONNECTIONS

1. The primary flow and return connections from the heat pump should be made to the flow and return connections of the cylinder. Refer to Figures 2-1 to 2-3, as appropriate.

On all cylinders except the standard 150 litre (QR2SC); connect the primary flow to the upper connection and the primary return to the lower connection.

For the standard 150 litre (QR2SC) cylinder only; connect the primary flow to the lower connection and the primary return to the upper connection.

The 2-Port motorised valve (supplied) may need to be fitted into the primary flow to the indirect coil. Refer to Section 3.3 for further information.

For all Grant QR2 cylinders:

- The primary flow and return fittings are 22mm compression.
 - The valve has 22mm compression connections.
2. Locate the dual thermostat probes in the stainless steel stat pocket (refer to Figure 2-3, for location) and secure using the retaining screws on the thermostat housing.
 3. Any automatic or manual air vent fitted to vent air from the upper coil should be installed on the primary flow pipe to the coil.

3.3 THE 2-PORT VALVE

The use of the 2-port motorised valve supplied with the cylinder depends on the type of heat source used with the indirect coil. Refer to Sections 3.3.1 and 3.3.2, as appropriate.

3.3.1 AIR SOURCE HEAT PUMP

If an Air Source Heat Pump is being connected to the indirect coil of the cylinder and the cylinder is being connected to an "S-Plan" type system, then the 2-port motorised valve (supplied) MUST be fitted into the primary flow to the indirect coil in order to prevent the temperature of the cylinder contents being lowered by a space heating demand.

Refer to item 2 in Figure 3-1. The 2-port valve should be wired in accordance with either Figure 5-3 or Figure 5-4 for a Grant Aerona Heat Pump (depending on the controller) to comply with current legislation. For other makes of heat pump please check with the heat pump manufacturer for connection details.

If an Air Source Heat Pump is being connected to the indirect coil of the cylinder and the cylinder is being connected to a "W-Plan" type system using a 3-port diverter valve (such as that supplied by Grant - Product code: HPID120), then the 2-port motorised valve (supplied) does not need to be fitted into the primary flow to the indirect coil.

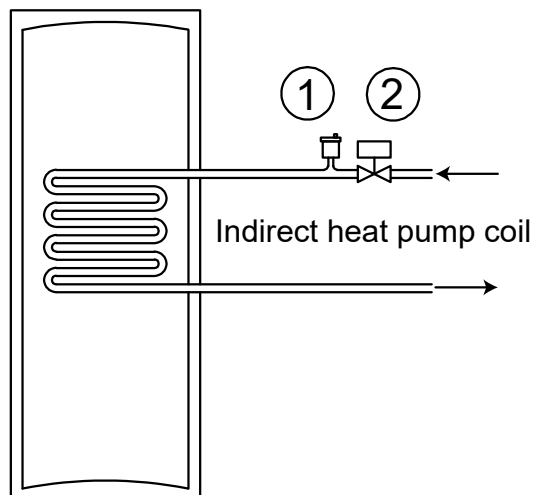

Figure 3-1: Primary circuit connections

Table 3-1: Key to Figure 3-1

Item	Description
1	Automatic Air Vent
2	Motorised 2-port valve

3.3.2 BOILER OR OTHER HIGH TEMPERATURE HEAT SOURCE

If a boiler or other high temperature heat source is being connected to the indirect coil of the cylinder, the 2-port motorised valve (supplied) MUST be fitted into the primary flow to the indirect coil of the cylinder, irrespective of system layout (eg S-Plan, Y-Plan, etc...). This must be done to comply with Building Regulations Approved Document G3.

Please check with the appliance manufacturer for connection details.

3.4 HARD WATER AREAS

If the cylinder is to be used with a boiler, in a hard water area, we recommend that the primary flow temperature be limited to 75 °C. This will help reduce the migration of suspended solids in the water and help prevent the build up of lime scale.

4 SECONDARY CIRCUIT INSTALLATION

4.1 GENERAL

Grant QR2 indirect Heat Pump cylinders are supplied with the safety devices and components loose in a kit, with the exception of the Temperature & Pressure (T&P) relief valve which is factory-fitted. These safety devices and components **MUST** be fitted to the cylinder as detailed in the following Sections 4.2 to 4.13. For a list of these safety devices and components refer to Table 2-4.

For commissioning and maintenance purposes, it is essential to fit a service valve (not supplied) in the cold water supply pipe, immediately before the inlet manifold.

The 1/2" drain cock is factory fitted in the cold feed to the cylinder to provide a means of draining the unit. Refer to Figures 2-3 for a suitable drain cock position that will enable most of the cylinder to be drained off when required.

4.2 COLD WATER INLET MANIFOLD

This manifold contains a pressure reducing valve, a check valve and expansion relief valve with a stainless steel seat.

The pressure reducing valve is factory set to 3 bar. The set pressure is shown on top of the valve. The maximum inlet pressure to this valve is 12 bar.

A balanced cold water connection is provided on the inlet manifold. Refer to Figure 4-1. This should only be used to provide balanced cold supplies to shower valves and mixer taps. If the balanced cold water outlet is not required, blank off this port.

4.3 INSTALLATION

1. Cold water supply pipe to be 22mm nominal size.

2. Flush supply pipework before connection to remove all flux and debris prior to fitting the inlet controls.

Failure to do this may result in irreparable damage to the controls and will invalidate the warranty.

3. Once the pipework is flushed connect the cold supply to the Inlet manifold.

The manifold can be installed in any position as long as it is installed in the correct flow direction. Refer to the arrows on the side of the body.

Make sure that the head of the expansion relief valve is offset from the cylinder for ease of access.

4. The expansion relief valve should be either horizontal or upright - if fitted inverted, debris may be deposited on the seat and cause fouling of the seat when the valve operates. Check direction of flow arrows.
5. If the installation requires one, a pressure gauge should be sourced and fitted on the cold water supply to the cylinder, between the inlet manifold and the cold water inlet tapping on the cylinder.
6. Connect the expansion vessel directly to the 3/4" BSPF connection in the inlet valve manifold body, after removing the black plastic plug. See Figure 4-1 and Section 4.4.
7. The expansion relief drain pipework must be connected to a safe visible discharge point via the tundish (supplied in the unvented hot water safety kit) and the pipework must have a continuous fall.
8. Connect the expansion relief valve outlet into the discharge pipe from the temperature and pressure Relief valve using a 15mm copper pipe and tee piece (not supplied). Fit the tundish below this tee piece using a short length of copper pipe. Refer to Sections 4.9 to 4.13 for further information on the Tundish and Discharge pipe.
9. The pressure reducing valve has two outlets, the second one is for a balanced cold water supply, to a shower or a bidet (over rim type only, ascending spray type requires type AA, AB or AD air gap).
Major shower manufacturers advise fitting a mini expansion vessel in the balanced cold supply to accommodate thermal expansion and prevent tightening of shower controls.
If the dwelling has a shower mixing valve (manual or thermostatic) or a Bidet (over rim type) use the cold water supply from the balanced cold water connection on the inlet manifold for these outlets.
Do not use the balanced cold connection to supply bath taps as this can reduce the flow of water available to the cylinder.
If the balanced cold water outlet is not required, blank off the connection.
10. The Service Log at the back of these instructions should be completed after commissioning of the system.
11. The cylinder must be registered with Grant UK within 30 days of installation. Refer to Section 13 for further details on the Cylinder guarantee.

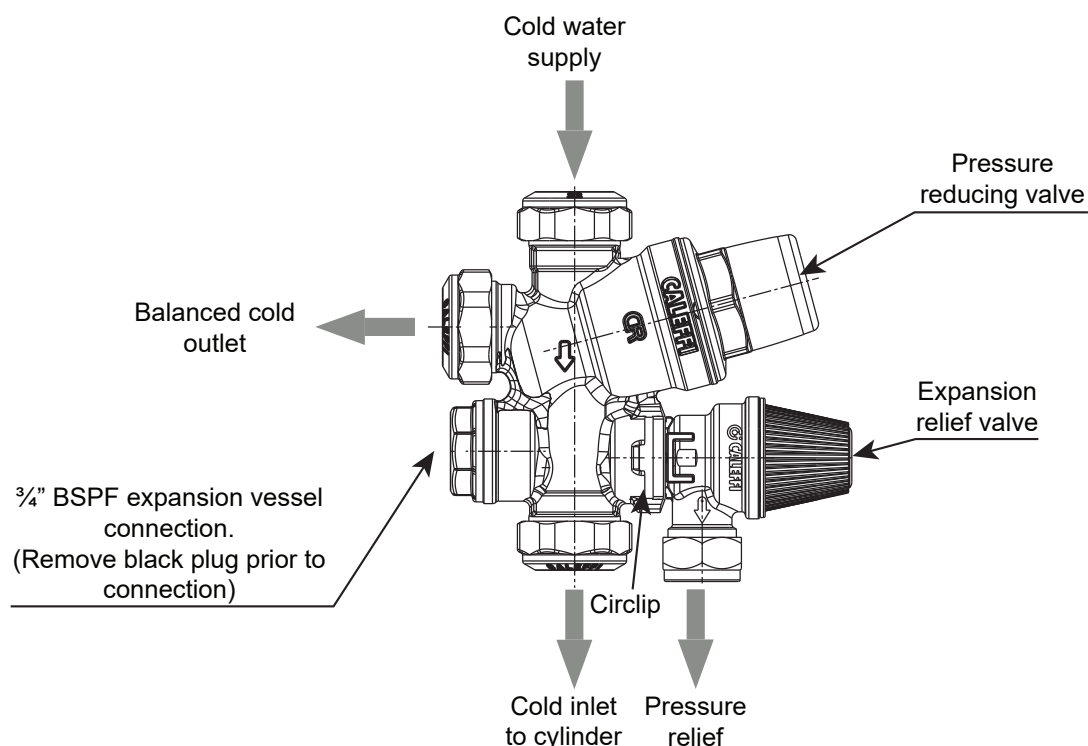

Figure 4-1: Cold water inlet manifold (orientation as fitted on a Grant QR2 cylinder)

4.4 EXPANSION VESSEL

A suitable expansion vessel with a pre-charge pressure of 3bar is supplied for fitting to all cylinders.

This expansion vessel must be connected into the cold water supply, between the expansion relief valve (in the inlet manifold) and the cold water inlet to the cylinder. Refer to Figure 4-1.

The preferred method of connection is to hard pipe the expansion vessel directly to the 3/4" BSPF connection in the inlet valve manifold body using 22mm diameter pipe. Refer to Figure 4-1.

To do this, with the cylinder in its final position and with all primary circuit connections to the cylinder made:

1. Remove the black plastic plug from the inlet manifold body (refer to Figure 4-1).
2. Screw the 3/4" BSPM x 22mm compression adapter (supplied) into the 3/4" BSPF connection in the inlet manifold body.
3. Mount the expansion vessel in a suitable position on an adjacent wall to the cylinder using the wall brackets on the vessel.

! NOTE !

The expansion vessel must be positioned with the connection point at the bottom.

No valve should be fitted between the expansion vessel and the cylinder.

4. Using 22mm diameter pipe and the 22mm compression nut and olive supplied with the expansion vessel, connect the expansion vessel to the inlet manifold.

The air charge pressure in the expansion vessel must be regularly checked (e.g. at every service) and topped up as necessary. The correct air charge pressure is 3.0bar.

Refer to Sections 7.1 and 7.4 for further details.

4.5 TEMPERATURE AND PRESSURE RELIEF VALVE

The temperature and pressure relief valve (T&P Valve) is supplied factory fitted to the cylinder. The T&P valve must not be removed from the cylinder or tampered with in any way. The valve is pre-set to lift at 7bar or 90 °C and any attempt to adjust it will invalidate the guarantee.

4.6 HOT WATER SUPPLY

Connect the hot water supply pipe to the top outlet of the cylinder. Refer to Figures 2-1 or 2-2, as appropriate.

4.7 PREVENTION OF SCALDING

Building Regulations Approved Document G (Part G3) requires that the hot water temperature supplied to a bath should be limited to a maximum of 48 °C by using an in-line blending valve (not supplied with the cylinder) with a maximum temperature stop.

The length of the supply pipe between the blending valve and the bath hot water outlet should be kept to a minimum to prevent the colonisation of waterborne pathogens (e.g. legionella). Refer to Approved Document G for further details.

4.8 SECONDARY RETURN

Grant QR2 indirect Heat Pump cylinders with a storage volume of 250 and 300 litres are fitted with a secondary return connection. If a secondary return circuit is required it should be connected to the cylinder as shown in Figure 4-2.

! NOTE !

If a secondary circulation circuit is installed then a larger expansion vessel may be required to handle the increase in volume. Contact Grant UK for guidance if necessary.

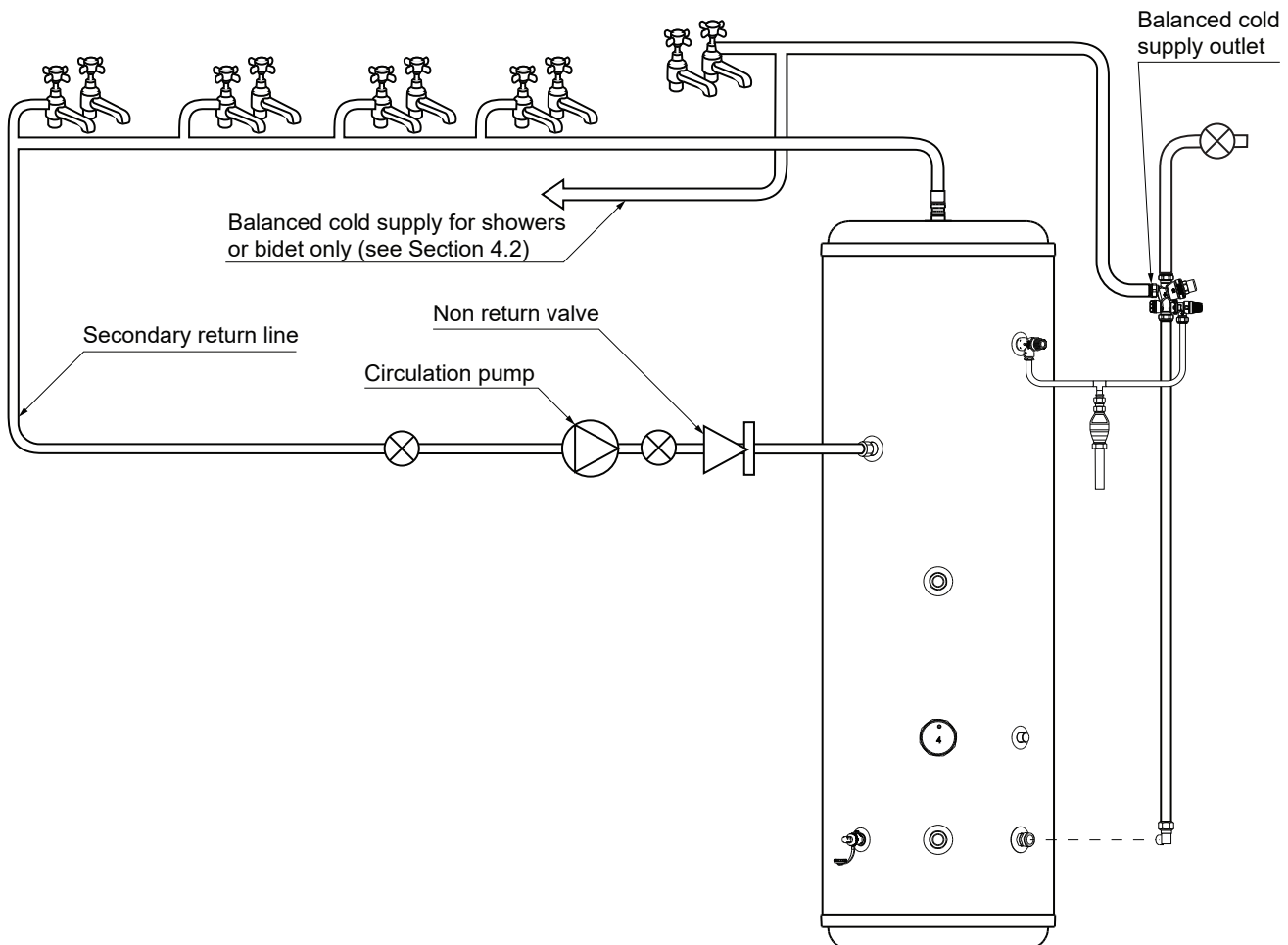

Figure 4-2: Secondary return circuit

4.9 TUNDISH

A suitable tundish is supplied loose with the cylinder for fitting in the common discharge pipe from the T&P and Pressure relief valves.

The tundish should be vertical, located in the same space as the unvented hot water cylinder and be fitted as close to, and lower than, the T&P valve with no more than 600mm of pipe (D1) between the valve outlet and the tundish. Refer to figure 4-3.

! WARNING !

The tundish must NOT be positioned above or in close proximity of any electrical current carrying devices or wiring.

A discharge pipe must be fitted to the outlet of the tundish. This must conform to the requirements as given in Sections 4.10 to 4.13 of these Installation and User Instructions.

4.10 DISCHARGE PIPE

- The discharge pipe (D2) from the tundish should terminate in a safe place where there is no risk to persons in the vicinity of the discharge.
 - It should be made of metal or other material that has been demonstrated to be capable of withstanding temperatures of the water discharged.
 - Be at least one pipe size larger than the normal outlet size of the safety device unless its total equivalent hydraulic resistance exceeds that of a straight pipe 9m long, i.e. for discharge pipes between 9m and 18m long the equivalent resistance length should be at least two sizes larger than the normal outlet size of the safety device, between 18m and 27m at least three sizes larger and so on.
Bends must be taken into account in calculating the flow resistance. Refer to Sections 4.11, 4.12 and 4.13.
 - Have a vertical section of pipe at least 300 mm long, below the tundish before any elbows or bends in the pipe work.
 - Be installed with a continuous fall of 1:200 (0.286°).
 - Have discharges visible at both the tundish and the final point of discharge but where this is not possible or practically difficult there should be clear visibility at one or other of these locations.
- Examples of acceptable discharge arrangements are:
 - ideally below a fixed grating and above the water seal in a trapped gully.
 - downward discharges at a low level; i.e. up to 100mm above external surfaces such as car parks, hard standings, grassed areas etc. are acceptable providing that where children may play or otherwise come in to contact with discharges, a wire cage or similar guard is positioned to prevent contact, whilst maintaining visibility.
 - discharges at high level; e.g. into a metal hopper and metal down pipe with the end of the discharge pipe clearly visible (tundish visible or not) or onto a roof capable of withstanding high temperature discharges of water and 3m from any plastics guttering systems that would collect such discharges (tundish visible).
- Where a single pipe serves a number of discharges, such as in blocks of flats, the number served should be limited to not more than 6 systems so that any installation can be traced reasonably easily.

The single common discharge pipe should be at least one pipe size larger than the largest individual discharge pipe to be connected.

If unvented hot water storage systems are installed where discharges from safety devices may not be apparent i.e. in dwellings occupied by blind, infirm or disabled people, consideration should be given to the installation of an electronically operated device to warn when a discharge takes place.

! NOTE !

The discharge will consist of scalding water and steam. Asphalt, roofing felt and non-metallic rainwater goods may be damaged by such discharges.

4.11 DISCHARGE PIPE SIZING

Refer to Table 4-1 (discharge pipe sizing).

Table 4-1: Discharge pipe sizing

Valve outlet size Diameter (inches)	Minimum size of discharge pipe D1 (mm)	Minimum size of discharge pipe D2 from tundish (mm)	Maximum resistance allowed, expressed as a length of straight pipe, i.e. no elbows or bends (m)	Resistance created by each elbow or bend (m)
½	15	22	Up to 9	0.8
		28	Up to 18	1.0
		35	Up to 27	1.4
¾	22	28	Up to 9	1.0
		35	Up to 18	1.4
		42	Up to 27	1.7
1	28	35	Up to 9	1.4
		42	Up to 18	1.7
		54	Up to 27	2.3

! NOTE !

The above table is based on copper tube. Plastic pipes may be of a different bore and resistance.

Sizes and maximum lengths of plastic pipe should be calculated using data for the type of pipe being used.

4.12 WORKED EXAMPLE

The example below is for a 1/2" diameter temperature relief valve with a discharge pipe (D2) having 4 x 22mm elbows and a length of 7 m from the tundish to the point of discharge.

From Table 4-1:

Maximum resistance allowed for a straight length of 22mm copper discharge pipe (D2) from a 1/2" diameter temperature relief valve is 9.0m.

Subtract the resistance for quantity of 4 x 22mm elbows at 0.8m each = 3.2m.

Therefore, the maximum permitted length is 9.0 - 3.2 = 5.8m.

5.8m is less than the actual length of 7m; therefore calculate the next largest size.

Maximum resistance allowed for a straight length of 28mm copper discharge pipe (D2) from a 1/2" diameter temperature relief valve is 18m.

Subtract the resistance for a quantity of 4 x 28mm elbows at 1.0m each = 4m.

Therefore, the maximum permitted length is 18 - 4 = 14m.

As the actual length is 7m, a 28mm diameter copper pipe will be satisfactory in this case.

4.13 DISCHARGE PIPE ARRANGEMENT

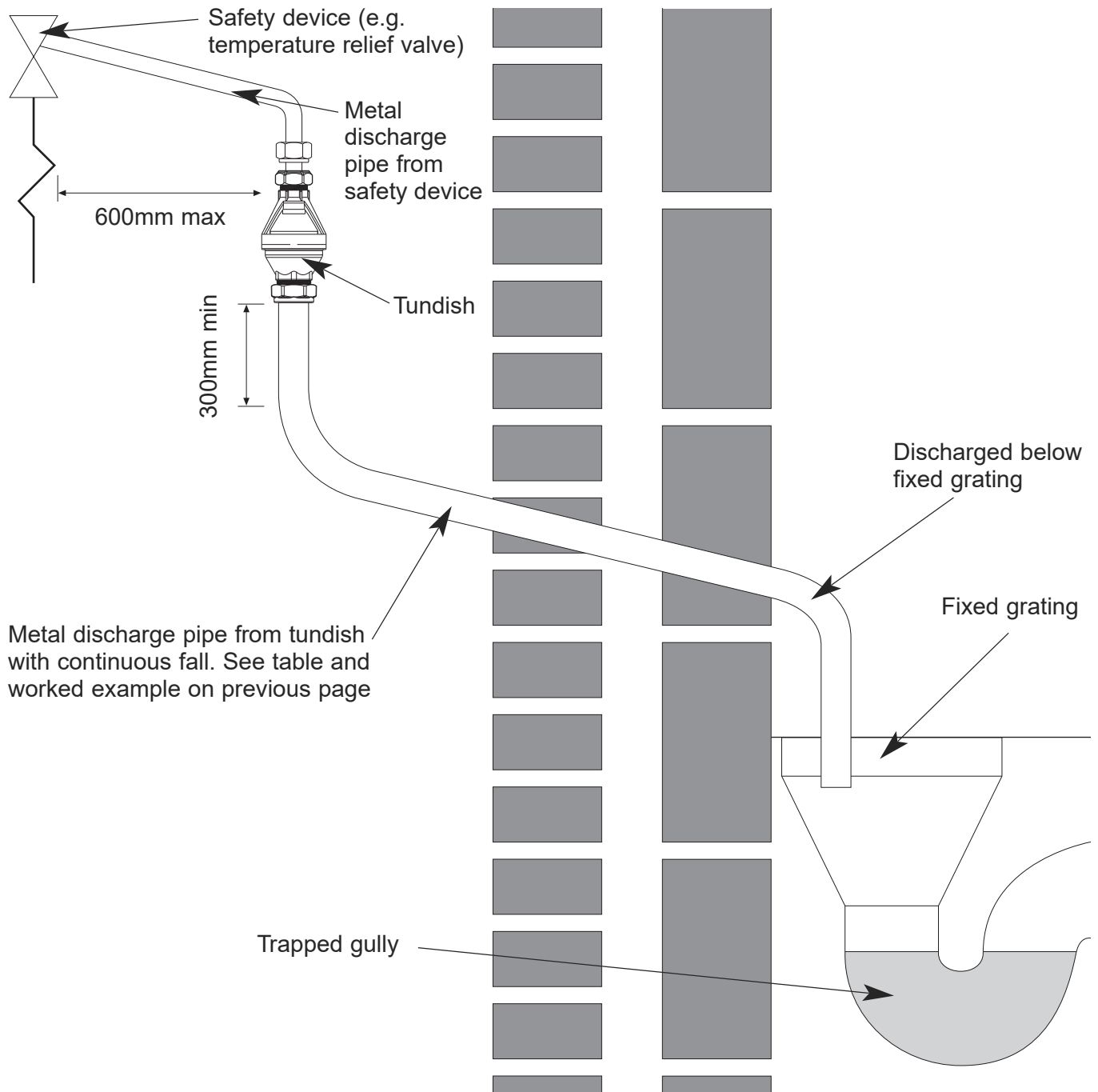

Figure 4-3: Typical discharge pipe arrangement

5 ELECTRICAL

All electrical wiring must be carried out by a competent person and in accordance with the current edition of BS7671 (the I.E.T. Wiring Regulations), including any amendments.

The control equipment supplied must be wired according to these Installation and User Instructions to ensure that the cylinder functions safely.

From an economic and convenience point of view, it is intended that these controls operate in conjunction with other control packages, for example, an "S-plan" type system that incorporates a programmer, etc.

5.1 IMMERSION HEATER

All Grant QR2 indirect Heat Pump cylinders are supplied factory-fitted with one 3kW immersion heater. This immersion heater conforms to:

- EN 60730-1:2016/A1:2019
- EN IEC 60730-2-9:2019
- EN IEC 60730-2-9:2019/A1:2019
- EN IEC 60730-2-9:2019/A2:2020
- EN 60730-1:2016
- Intertek BEAB Mark:
- EN60335-1:2012, A11, A13, A1, A2, A14, A15
- EN60335-2-73:2003+A1, A2, A11

The control thermostat is pre-set on position "4.5" at a temperature of approximately 61.5 °C(±3 °C). Refer to Figure 5-1.

Installation and wiring instructions for the immersion heater are supplied with each unit. The wiring connections are also shown in Figure 5-1. Follow the wiring instructions connecting the live, neutral and earth as indicated.

The immersion heater must be permanently connected to the electrical supply through a double-pole isolator. A safety cut-out is also incorporated within the thermostat and is factory set to operate at 83 °C(±5 °C).

The immersion heater is factory fitted to the cylinder. If the immersion heater needs to be replaced it must be fitted to the cylinder using the gasket provided on the unit. Only use a correctly shaped spanner. Stilsons or pipe grips should not be used. The use of sealing compound is not recommended.

! WARNING !

The immersion heater must NOT be used unless it is fully immersed in water.

Always ensure that the cylinder is full of water BEFORE switching on the electrical supply.

Refer to Figures 2-1 & 2-2 (as appropriate) for the position of the immersion heater.

5.2 IMMERSION HEATER WIRING INSTRUCTIONS

Ensure that the supply voltage corresponds to the voltage rating of the immersion heater as shown on the rating label on the terminal cover.

Each 3kW 230V 50Hz-immersion heater should be wired in accordance with the instructions given in Figure 5-1.

The cable must be routed through the strain relief bush. The cable grip should be secured using only the screws provided.

It is the installer's responsibility to wire the immersion heater and it can be run through a double pole isolator or double-pole switched fused spur with a minimum rating of 13A and a contact separation of at least 3mm.

The installer will need to size the supply cable to the immersion heater depending on the distance the isolator is from the immersion heater.

The installer should use a suitable sized, heat resistant cable for final connection to the immersion heater. 3183TQ or 3093Y are the most common ones and are both rated to 90 °C, and 1.5mm² is suitable for up to 16A. The immersion heater must be earthed.

! WARNING !

Always ensure that the immersion heater cap is not covered.

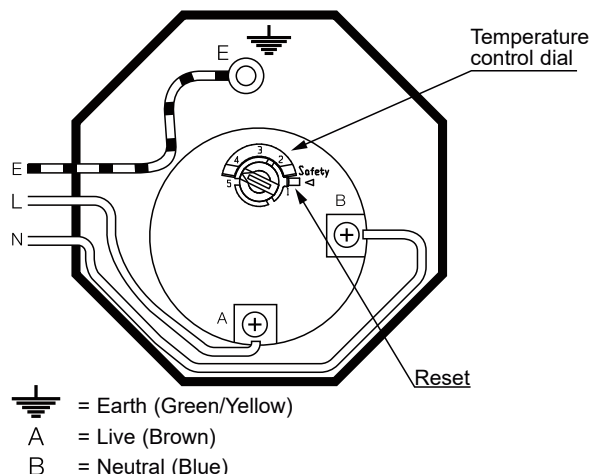

Figure 5-1: Immersion heater wiring connections

! WARNING !

This immersion heater must be earthed.

! WARNING !

The manual reset high limit thermostat must not under any circumstances be by-passed. This is pre-set to 70 °C (±5 °C) and to prevent nuisance tripping, the control thermostat should always be left in the 4.5 position. (For temperature of approximately 61.5 °C(±3 °C). Refer to Figure 5.2

5.3 IMMERSION HEATER SAFETY CUT-OUT

The immersion heater incorporates an independent non self-resetting over temperature cut-out device to prevent excessive water temperatures.

In normal operation the reset pin is positioned to the right-hand side of the control knob and is indicated by a triangle (with the word 'safety' above) will be approximately 2-3mm below the upper surface of the thermostat cap. Refer to Figure 5-2.

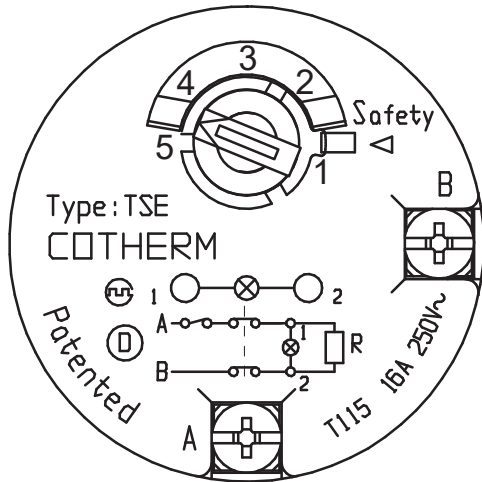

Figure 5-2: TSE single pole thermostat plan view details

Should the over temperature cut-out operate:

- The reset pin will be pushed upwards to become level with or slightly above the cover.
- Wait until the temperature has fallen sufficiently.
- Investigate and identify the cause of the cut-out operation and rectify the fault.

Manually reset the cut-out by pressing in the reset pin to its normal operating position using hand pressure only with a suitably sized implement.

! WARNING !

Before removing the immersion heater covers to either reset the safety cut-out or check/alter the thermostat setting, ensure that the electrical supply is isolated.

Ensure the cover to the immersion heater cover is replaced correctly and the retaining nut is fitted. Finally switch the mains electricity supply back on.

5.4 DUAL THERMOSTAT

A dual thermostat (a combined control and high limit thermostat) is supplied separately with the cylinder (two are supplied with twin coil models).

The Dual Thermostat probes are to be fitted into the sensor pocket in the cylinder (refer to items 3 in Figure 2-3, for position) to control the operation of the heat pump.

The cylinder control thermostat has an adjustment range between 25 °C and 65 °C. It is recommended that it is set between 25 °C and 55 °C for Grant Aeronas Heat Pump installations.

The high limit (overheat) thermostat will automatically operate at 90 °C.

For details on the correct wiring connections, refer to Figures 5-3 to 5-5 (as appropriate).

5.5 2-PORT VALVES

To comply with the regulations governing the installation of indirect unvented hot water cylinders, a 2-port motorised valve (supplied) may need to be fitted to the primary flow to the indirect coil of the cylinder.

If your cylinder is being installed as part of an ASHP installation, refer to Section 3.3.1 for further information.

If your cylinder is being installed as part of a boiler (or other high-temperature heat source) installation, refer to Section 3.3.2 for further information.

5.6 HEAT PUMP INTERFACE BOX

The Grant EP002 Heat Pump interface box (supplied with all Grant Aeronas air source Heat Pumps) is designed to provide the voltage free switching for the Aeronas air source Heat Pump, using the space heating and hot water switched live outputs from the control system wiring centre.

This box can be installed next to the heating system wiring centre. Alternatively, it can be located nearer to the Aeronas Heat Pump, but NOT be installed externally.

Refer to the Aeronas installation instructions for further details.

This interface box is NOT required when the cylinder is used with a Grant Aeronas 290 Heat Pump or Grant oil boiler.

5.7 WIRING DIAGRAMS

The control system shown in this diagram includes the Grant hot water priority relay (product code: HPWPR1). This ensures that there can be no demand for space heating and hot water at the same time.

Any demand from the Grant HPIDTM4 DHW Timer and cylinder thermostat for hot water will activate the relay, immediately interrupting any heating demand from the Grant NeoStat. This will remain interrupted until the demand for hot water stops - either the cylinder thermostat is satisfied or there is no hot water output from the timer.

For information regarding the operation of the DHW Boost Kit shown in this control system wiring diagram, please refer to Section 5.4 of the Aerona³ ASHP installation instructions.

Aerona ³ ASHP Wiring Terminals	
19	Hot water
20	Heating
18 and 21	Common

! NOTE !

The volt free remote contact is provided by the Grant EP002 Interface relay box. Refer to the installation instructions supplied with the Aerona³ ASHP for further details.

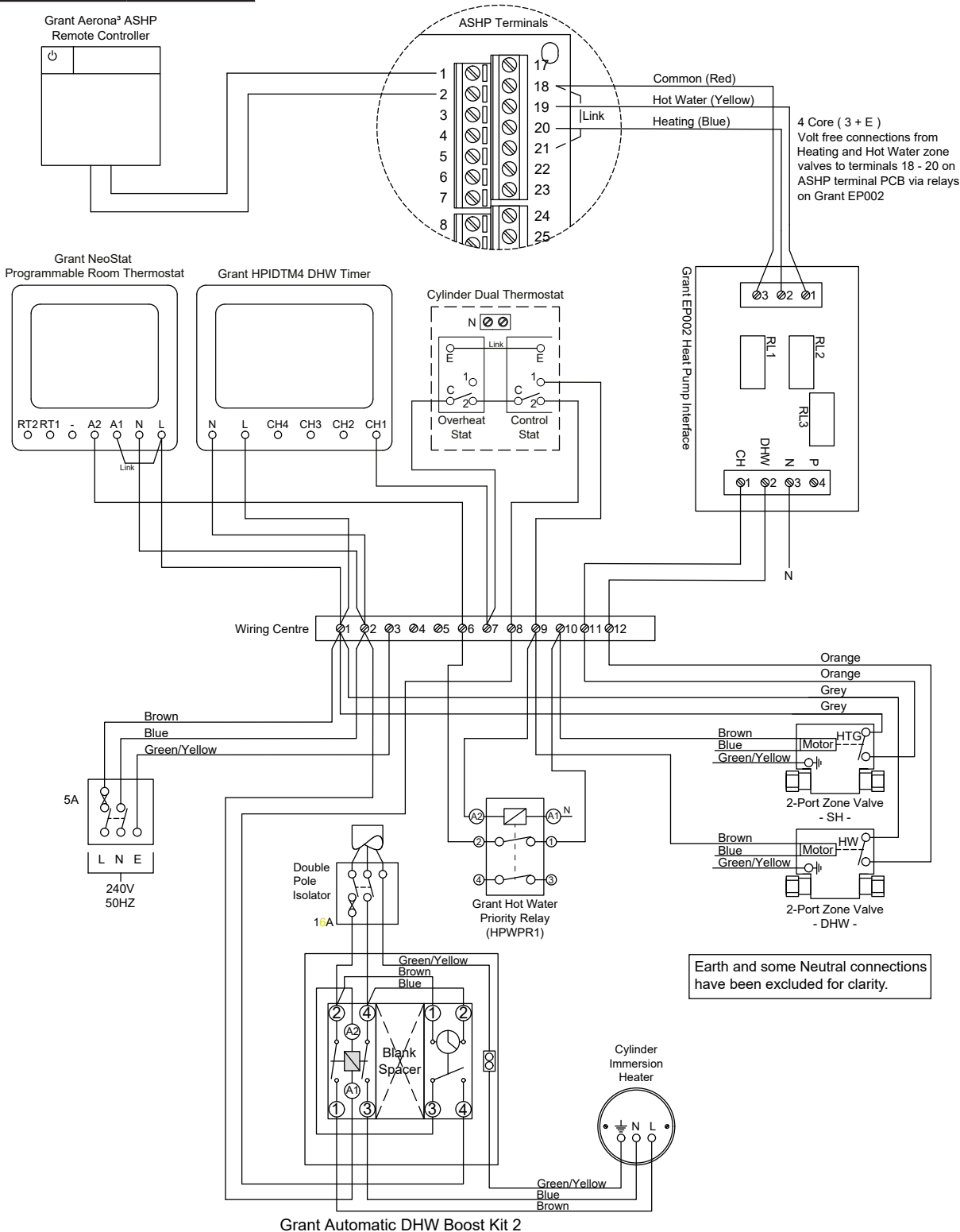

Figure 5-3: S-plan system connection diagram with Grant HW priority relay and DHW Boost Kit 2

5.7.1 SMART CONTROLLER - AERONA³

! NOTE !

Some Neutral and Earth connections have been excluded for clarity. Grant Smart Immersion relay to house 2 live connections. Ensure both are isolated prior to opening housing.

! NOTE !

Please, ensure that neutrals are derived from the same supply to prevent spurious MCB/RCD trips.

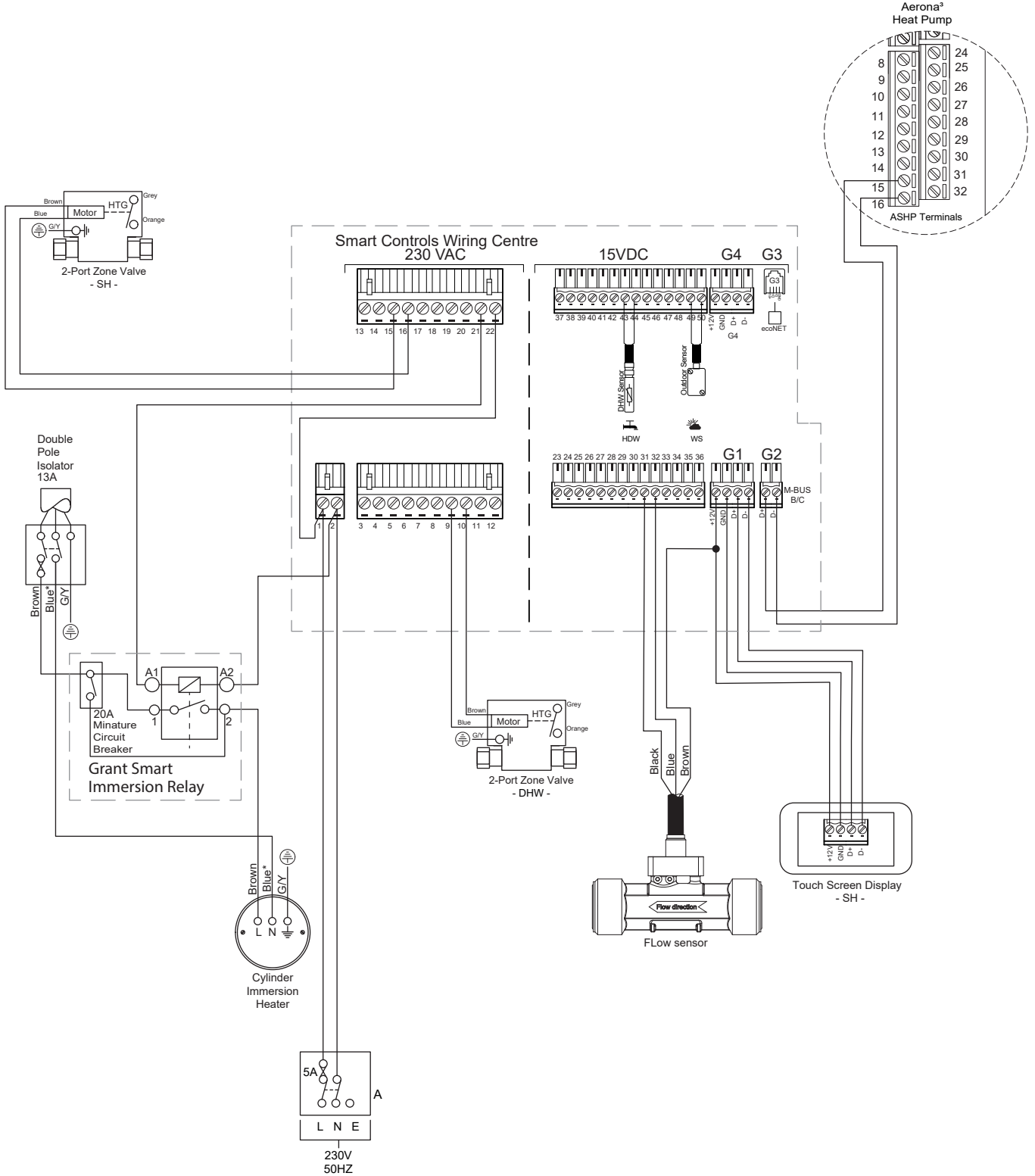

Figure 5-4: S-plan system connection diagram with HW priority provided by the Grant Smart Controller - R32 Heat Pump

5.7.1 SMART CONTROLLER - AERONA 290

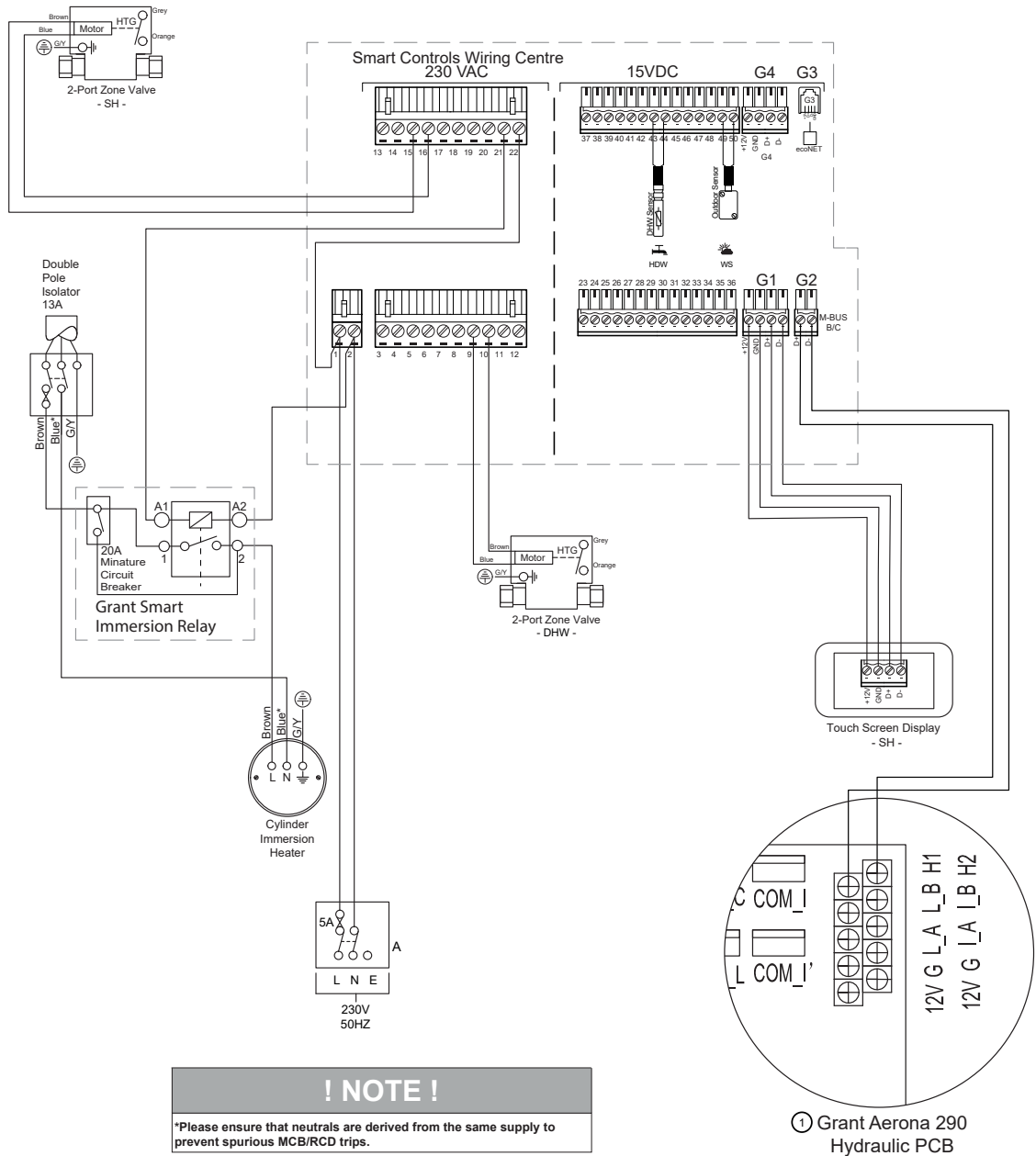

Figure 5-5: S-plan system connection diagram with HW priority provided by the Grant Smart Controller- R290 Heat Pump

6 COMMISSIONING, DRAINING DOWN AND SAFETY

! NOTE !

Commissioning details should be entered in the commissioning and service log at the back of these instructions.

6.1 FILLING THE CYLINDER

! CAUTION !

Before filling the cylinder check that the immersion heater has not loosened in transit. Tighten as necessary using a shaped spanner. Stillsons or pipe grips should not be used.

1. Ensure that all connections are fully tightened.
2. Ensure that the service valve in the cold water supply is closed.
3. Open all hot water taps supplied by the cylinder.
4. Slowly open the service valve in the cold water supply.
5. Continue to fill the cylinder until water flows from all taps.
6. Open the service valve fully and close all the hot taps.
7. Allow system to stabilise for five minutes.
8. Open each hot water tap in turn to expel air from the system pipe work.
9. Check for leaks.
10. Manually operate Temperature and Pressure Relief Valve (13) – Figure 2-3, to ensure free water flow through discharge pipe. (Turn knob to left).
11. Heat the water to chosen temperature and then close the service valve.
12. Drain the cylinder to flush out any flux/solder from the installation process. Refer to Section 6.2 below.
13. Re-fill the cylinder – as described above.
14. Re-heat cylinder to the required temperature and re-check for leaks.

6.2 DRAINING DOWN

1. Switch off the electrical power to the immersion heater (important to avoid damage to the element).
2. Switch off the heat pump (or boiler).
3. Turn off the cold water service valve (or stop cock).
4. Attach a hose to the drain cock, ensuring that it terminates at a level below the hot water cylinder.
5. Open all hot water taps.
6. Open drain cock in cold water supply to drain unit down. Refer to Figure 2-3.

! WARNING !

Water drained from hot water cylinder may be very hot!

! CAUTION !

After draining the cylinder do not close the hot taps until the cylinder has fully cooled. Failure to follow this instruction may result in damage to the cylinder and will invalidate the guarantee.

6.3 IMMERSION HEATER SAFETY CUT-OUT

The immersion heater incorporates an independent non self-resetting over temperature cut-out device to prevent excessive water temperatures. Refer to Section 5.3 for further details.

The safety cut-out will operate if:

- a. The wiring is incorrect.
- b. The immersion heater thermostat or cylinder thermostat fails.
- c. Thermostat is set too high.

To reset the safety cut-out:

1. Unscrew and remove the nut holding the immersion heater cover in place.
2. Remove the immersion heater cover.

! WARNING !

Before removing the immersion heater cover, to either reset the safety cut-out or check/alter the thermostat setting, ensure that the electrical supply is isolated.

3. The safety cut-out reset pin is positioned to the right-hand side of the control knob (indicated by a triangle with the words 'safety' above). Refer to Figure 6-1.
4. If the cut-out has operated, the reset pin will be pushed upwards (to be level or slightly above the cover).
5. Wait until the temperature has fallen sufficiently.
6. Investigate and identify the cause of the cut-out operation and rectify the fault.
7. Press in the reset pin (to its normal operating position) to reset the cut-out. Use hand pressure only with a suitably sized implement.
8. Refit the immersion heater cover correctly and secure in position with retaining nut.
9. Switch the mains electricity supply back on.

If the problem persists, please contact your installer.

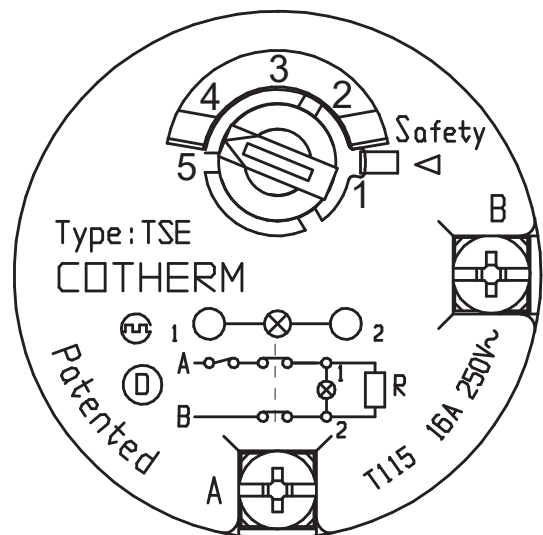

Figure 6-1: TSE single pole thermostat plan view details

6.4 COLD WATER DISCHARGE FROM TUNDISH

There are two reasons why cold water will discharge from the tundish:

1. The pressure reducing valve has malfunctioned (This will cause a large volume of water to flow through the tundish).
2. The Expansion relief valve is letting by (This will cause a very low volume of water to flow through the tundish).

In both cases, identify the defective component and replace. All repairs must be carried out by a competent person.

6.5 HOT WATER DISCHARGE FROM TUNDISH

There are four reasons why hot water will discharge from the tundish:

1. Thermal cut-out has malfunctioned.
2. The control thermostat has malfunctioned.
3. The T & P valve is letting by.
4. The expansion vessel has failed or lost its charge.

In all cases, should a repair be necessary, the work must be carried out by a competent person.

Isolate the cylinder from all electrical supplies before commencing maintenance work.

6.6 EXPANSION VESSEL

1. The expansion vessel is connected into the cold water supply to the cylinder.

! NOTE !

No valve should be fitted between the expansion vessel and the supply pipe.

2. Ensure that the air charge in the vessel matches the pressure setting shown on the pressure reducing valve.
3. The expansion vessel must be installed even if an accumulator is fitted.
4. The charge of the vessel must be checked at every annual service.

6.7 CUSTOMER HANDOVER

1. Complete the commissioning and service log at the back of these instructions and leave the instructions with the user.
2. Explain the operation of the system to the User, referring to Section 12 of these instructions.
3. In particular, make the user aware of what to do if water is seen to flow from either the T&P Valve or Expansion relief Valve.
4. Refer the user to the Information given in Section 12 of these instructions.

! NOTE !

Leave these Installation, Servicing and User instructions with the user for future reference.

7 MAINTENANCE

! NOTE !

Servicing details should be entered in the commissioning and service log in Appendix A at the back of these instructions.

7.1 SERVICING AND MAINTENANCE

1. Servicing and maintenance must only be carried out by a competent unvented hot water installer, or by Grant Engineering (UK) Limited authorised personnel.
2. Before any work whatsoever is carried out on the installation, it MUST first be isolated from the electricity supply.

! WARNING !

Both the primary and secondary systems will contain very hot water that will scald; therefore care should be taken when opening any joints, seals or valves.

3. Only use spare parts authorised by Grant Engineering (UK) Limited. The use of unauthorised spare parts will invalidate the guarantee.
4. Drain the cylinder – When draining the cylinder, always switch off the boiler/heat pump and the immersion heater first. Turn off the water supply at the service valve or mains stopcock.
Connect a hose pipe to the drain cock (Refer to Figure 2-3) and route it to a convenient gully. Open the drain cock and all hot taps that are served by the cylinder. The cylinder may take several minutes to empty completely.
5. In hard water areas it may be necessary from time to time to remove and de-scale the immersion heater element. Replace the gasket each time it is removed.
6. Check any in-line strainers which may be fitted in the cold supply to the cylinder and clean if necessary.
7. Remove the expansion relief valve. Check and clean valve seat. Replace valve. Refer to Section 7.3 for further information.
8. Check the charge pressure in the expansion vessel and top up as necessary. The charge pressure should be 3.0 bar. Refer to section 7.4 for further information.
9. Whilst the hose pipe is connected, the drain cock open and with the immersion heater removed, the cylinder may be flushed out to remove any debris, sand or lime scale particles that may have collected in the bottom by using a further hose pipe connected to the cold water main.

! NOTE !

For inspection access use the immersion heater boss after removing the immersion heater.

10. Close the drain cock, disconnect the hose, refit the immersion heater and close all hot water taps before re-opening the stopcock. Allow the cylinder time to fill whilst checking for any leaks. Release any air from the system by opening each hot water tap individually, starting with the one furthest from the cylinder.
11. Manually lift the expansion relief and temperature and pressure relief valve one at a time, every 12 months (more frequently in hard water areas) to prevent debris from building up behind the valve seat. Whilst carrying out this operation, check that the discharge to waste is unobstructed. Check that each valve seals correctly when released. As the valves are pre-calibrated, they require no further maintenance.
12. Finally switch on the mains electricity supply to the immersion heater, heat pump, or the boiler. As the system heats up, check again for any leaks and rectify as necessary.

7.2 INLET MANIFOLD ASSEMBLY

The inlet manifold assembly should not, under normal circumstance, require any maintenance. During annual servicing it may be necessary to inspect and/or clean the expansion relief valve. The frequency of cleaning will depend on the local water conditions.

7.3 EXPANSION RELIEF VALVE

Isolate the cold water supply.

Remove the un-sprung circlip retaining the expansion relief valve in the inlet manifold body. See Figure 4-1.

Carefully remove the expansion relief valve from the inlet manifold body. It is a push fit type fitting, so gently pull on the body of the expansion relief valve until it is released.

Clean valve seat face and seating - do not scratch or damage either seat face or seating.

Refit in reverse order.

Ensure that the circlip is fully inserted into its seat.

Expansion relief valve (Grant UK product code: GCS34X)

Upon re-fitting the circlip used to retain the push-fit expansion relief valve into the inlet manifold body, ensure the circlip is fully inserted into its seat.

7.4 EXPANSION VESSEL

1. Isolate the cold water supply.
2. Open hot water taps.
3. Drain cylinder to below the expansion vessel flexible hose connection.
4. Check expansion vessel air charge.
5. Replace expansion vessel if necessary.
6. Close drain off cock and turn on cold water supply.
7. Refill cylinder whilst checking for leaks.
8. When water is flowing freely from taps close taps.

8 FAULT FINDING

8.1 INTERMITTENT WATER DISCHARGE

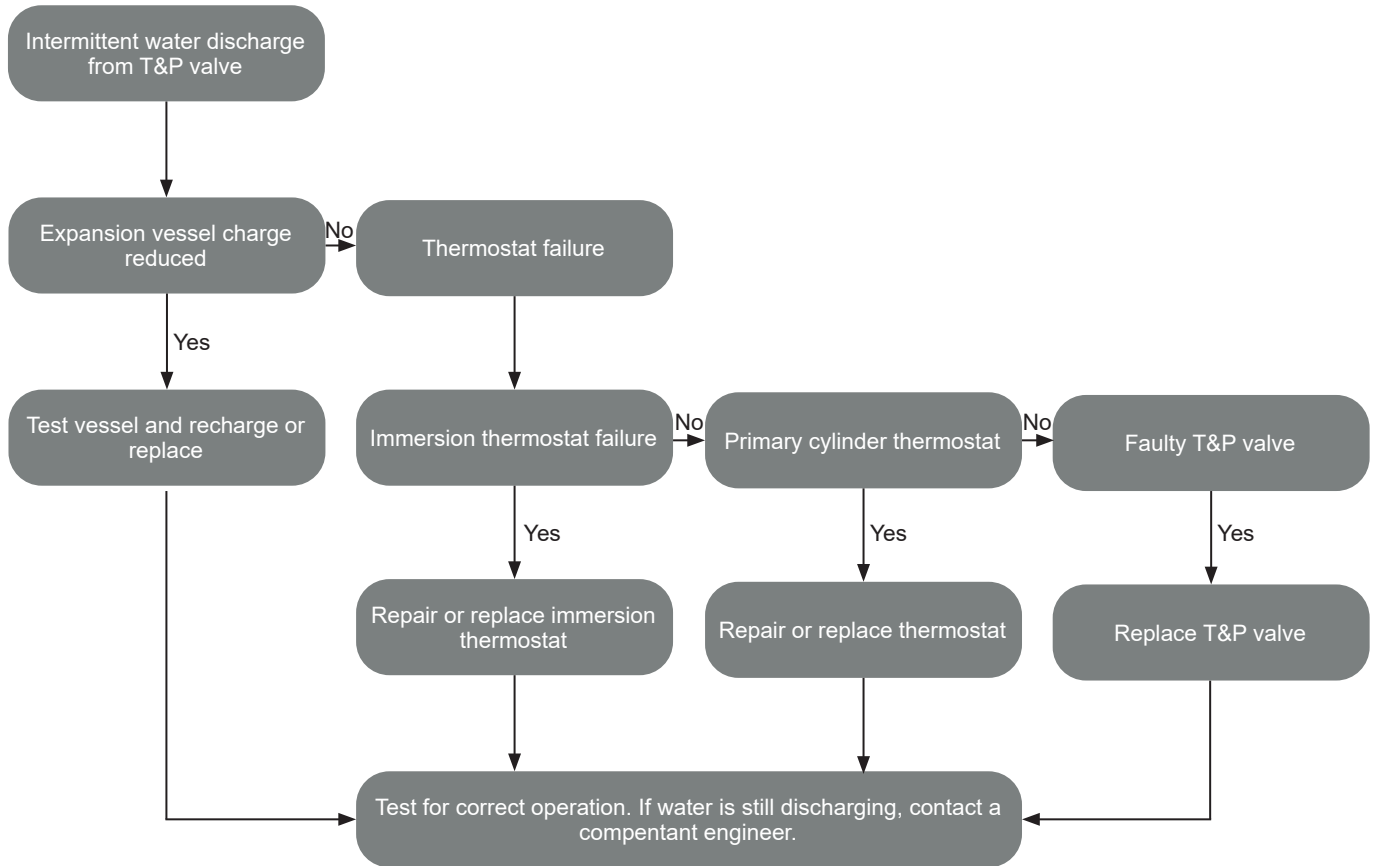

8.2 CONSTANT WATER DISCHARGE

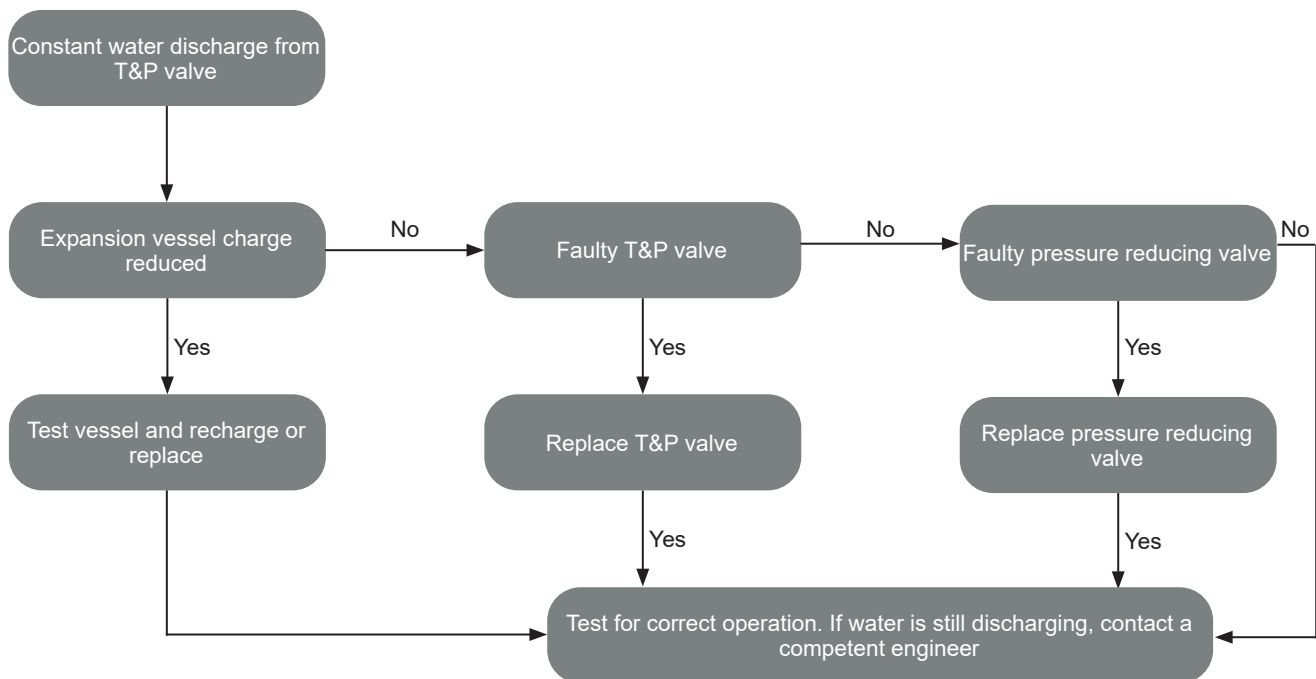

8.3 NO FLOW FROM HOT WATER TAPS

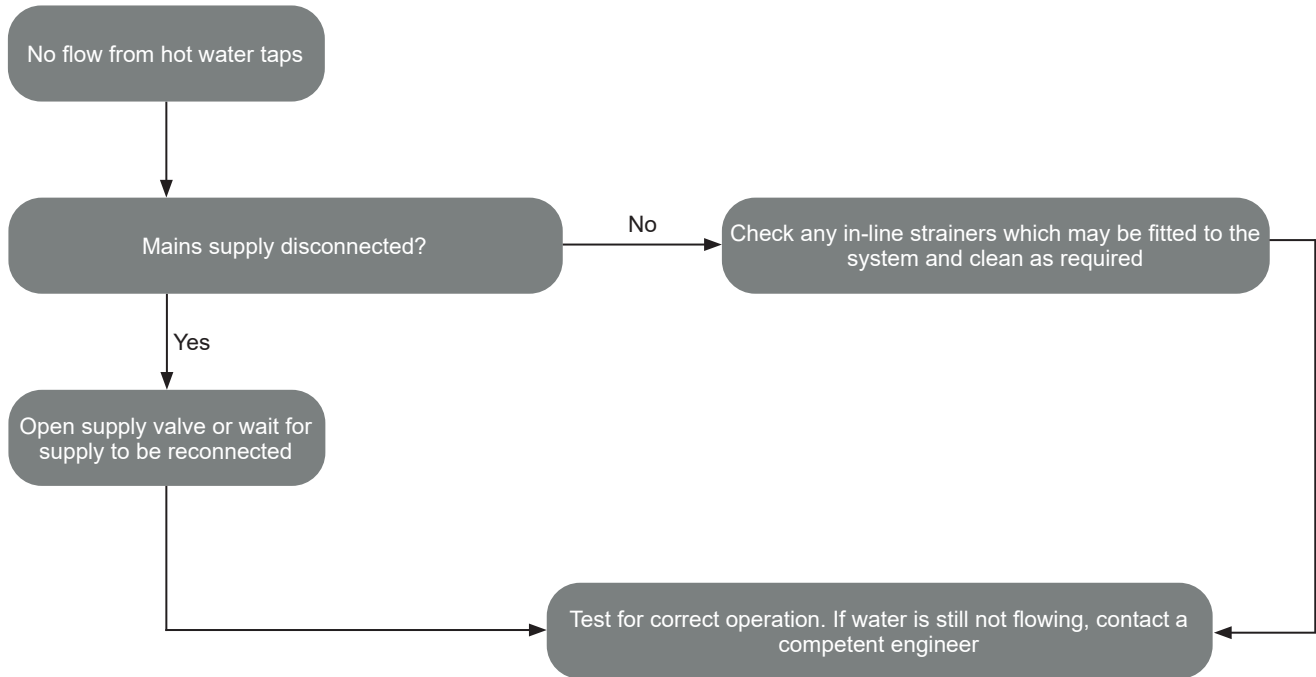

8.4 COLD WATER FLOW FROM HOT WATER TAPS

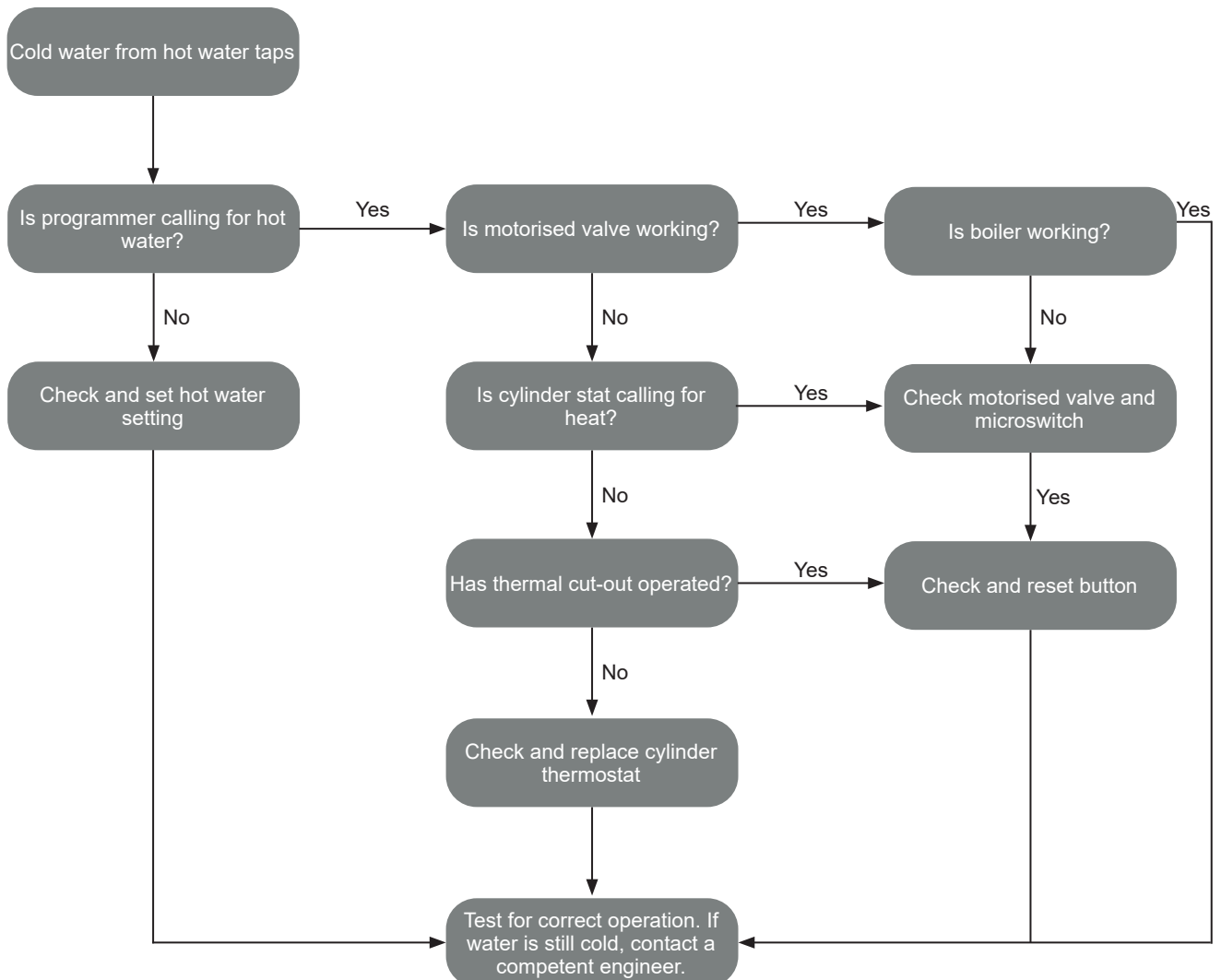

8.5 EXCESSIVE HOT WATER FROM TAPS

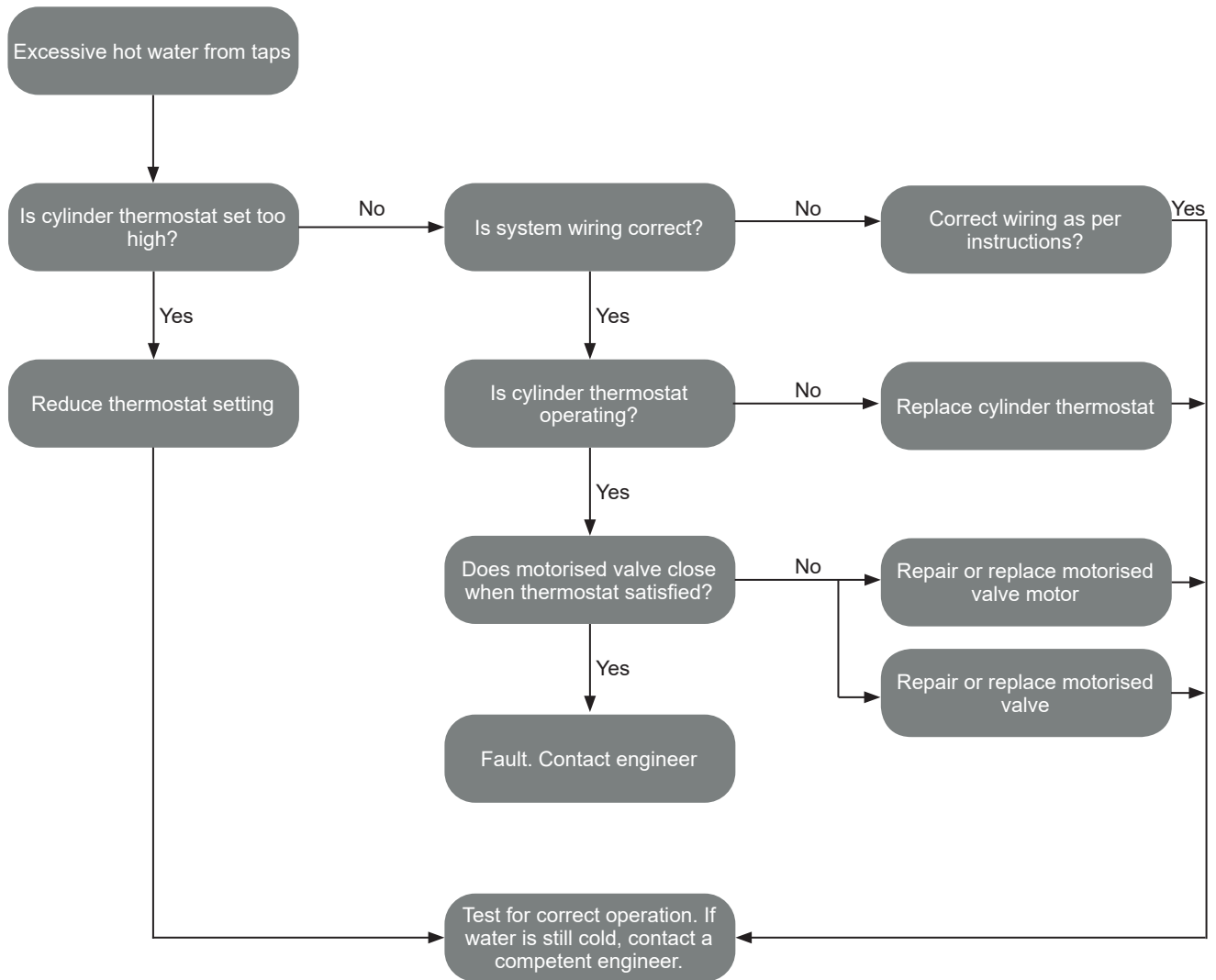

9 SPARE PARTS

9.1 SPARE PARTS

Table 9-1: Grant QR indirect HP cylinders - spare parts

Product description	Product code
Inlet manifold c/w 3 bar pressure reducing valve and 6 bar expansion relief valve	GCS07X
Safety/Pressure Relief valve - 6 bar - push fit	GCS34X
½" Temperature and pressure relief valve 90 °C / 7 bar - All models except 300L	GCS09
¾" Temperature and PRV - 7 bar/90 °C - 300L only - 300L only	GCS17
Tundish - 15mm / 22mm compression - all models except 300L	GCS10
Tundish - 22mm / 28mm compression - 300L only	GCS22X
Dual thermostat (control: 25-65 °C / high limit: 90 °C)	GCS11
TS00014 immersion heater thermostat only	GCS40
½" Drain cock with ¾" outlet	GCS14X
3kW immersion heater element and TS00014 immersion heater thermostat	GCS41
2-port motorised valve (22mm)	GCS20X
18 litre expansion vessel with 22mm compression fitting (all models EXCEPT 250L & 300L)	GCS01A
25 litre expansion vessel with 22mm compression fitting (250L & 300L models only)	GCS04A
Expansion vessel mounting bracket - All models	GCS03X

10 PRODUCT FICHE

Product fiche concerning the
COMMISSION DELEGATED REGULATIONS
(EU) No 812/2013 of 18 February 2013
(EU) No 814/2013 of 2 August 2013

Model	Model identifier	Energy efficiency	Standing loss (kW/h/24hrs)	Storage volume (litres)
QR2SC	QR2SC150	B	1.15	135
QR2SC	QR2SC180	B	1.21	168
QR2SC	QR2SC210	B	1.41	200
QR2SC	QR2SC250	B	1.54	238
QR2SC	QR2SC300	C	1.81	281
QR2SCSL	QR2SC150SL	B	1.24	127
QR2SCSL	QR2SC180SL	B	1.40	170
QR2SCSL	QR2SC210SL	C	1.57	200

11 END OF LIFE INFORMATION

GENERAL

Grant hot water storage cylinders incorporate components manufactured from a variety of different materials. The majority of these materials can be recycled whilst the smaller remainder cannot.

Materials that cannot be recycled must be disposed of according to local regulations using appropriate waste collection and/or disposal services.

DISASSEMBLY

There is little risk to those involved in the disassembly of the cylinder if the process is undertaken with care and reasonable precautions are taken.

RECYCLING

Many of the materials used in Grant hot water storage cylinders can be recycled, as listed below:

COMPONENT

Shell
Internal coils
Bosses
Compression connections
Outer casing
Top/bottom caps
T&P valve
Immersion heater
Insulation

MATERIAL

Stainless steel (Duplex 2304)
Stainless steel
Stainless steel (316L)
Brass
Galvanised steel with polyester and polyethylene terephthalate (PET) coating
ABS
Brass
Brass/stainless steel
Polyurethane foam; 50mm around and 75mm for top section

DISPOSAL

All materials other than those listed above must be disposed of responsibly as general waste.



Neil Sawers
Technical Manager

12 USER INSTRUCTIONS

12.1 USER INSTRUCTIONS

Your Grant QR2 indirect Heat Pump cylinder has been designed to give many years of trouble-free service and is made from hygienic high grade stainless steel.

12.1.1 IMMERSION HEATERS

Your Grant QR2 indirect Heat Pump cylinder is fitted with one 3kW immersion heater. Refer to Section 5.1 for further details.

The immersion heater in the cylinder can be used to heat your hot water when your heat pump (or boiler) is switched off, e.g. during the summer months.

In the case of a Grant Aerona heat pump, this immersion heater may also be used to assist in the heating of your hot water. Check with your installer.

The cylinder immersion heater thermostat has been factory-set to position 4.5 (refer to Figure 5-1) to give a hot water temperature of around 61.5 °C(±3 °C).

The immersion heater incorporates an independent non self-resetting over temperature cut-out device to prevent excessive water temperatures. If this safety cut-out operates it can be re-set. Refer to Section 6.3.

If the problem persists, please contact your installer.

12.1.2 DIGITAL DUAL THERMOSTAT

Your Grant QR2 indirect Heat Pump cylinder is also fitted with a Dual Thermostat (mounted on the cylinder). Refer to Section 5.4 for further details.

The cylinder control thermostat has an adjustment range between 25 °C and 65 °C. It is recommended that it is set between 50 °C and 55 °C for Grant Aerona³ Heat Pump installations.

The high limit (overheat) thermostat will automatically operate if the water temperature reaches 90 °C. If this operates it can be re-set. To do this, first wait for the cylinder to cool down. Then unscrew the plastic cap and press in the small re-set pin.

If the problem persists, please contact your installer.

12.1.3 TEMPERATURE SETTINGS

The hot water temperatures on the cylinder immersion heater thermostat and dual thermostat should not be set any higher than 65 °C otherwise nuisance tripping of either the immersion heater safety cut-out, or the high limit thermostat (in the dual thermostat) will occur. However this temperature could be decreased between 60 °C and 65 °C if required, to suit your requirements.

Grant UK recommends that the Digital Dual Thermostat is set between 60 °C and 65 °C for Grant Aerona Heat Pump installations.

Setting a lower target temperature will help to minimise the build-up of lime scale and is likely to increase the longevity of your hot water cylinder.

If you are in any doubt, these temperatures adjustments should be best left to your installer.

12.1.4 HOT WATER

When a hot tap is turned on there may be a short surge of water, this is quite normal with unvented systems and does not mean there is a fault.

When you first fill a basin the water may sometimes appear milky. This is due to very tiny air bubbles in the water, which will clear very quickly.

! WARNING !

If water is seen to flow from either the Temperature & Pressure Relief (T&P Valve) valve or the Expansion Relief Valve (EV) on the cylinder seek expert advice immediately.

If the water is flowing from the T&P Valve, immediately:

1. Shut off the electrical supply to the immersion heater(s).
2. Shut down the boiler or other heat sources to the cylinder e.g. solar, heat pump, etc.
3. DO NOT SHUT OFF THE WATER SUPPLY TO THE CYLINDER.
4. Contact your installer to check the system.

IMPORTANT

Do NOT tamper with any of the Safety controls fitted to the cylinder. If you suspect a fault always contact a competent installer who is qualified to work on unvented water cylinders.

13 GUARANTEE

You are now the proud owner of a cylinder from Grant Engineering (UK) Limited, which has been designed to give you years of reliable, trouble free operation.

Grant Engineering (UK) Limited guarantees the manufacture of the cylinder including all electrical and mechanical components for a period of **twelve months from the date of installation**⁴, provided that the cylinder has been installed in full accordance with the installation and servicing instructions issued.

This will be extended to a total period of **two years** if the cylinder is registered with Grant Engineering (UK) Limited **within thirty days of installation**⁴ and is serviced at twelve monthly intervals³. See main Terms and Conditions below.

In addition, the stainless steel (shell) used in the manufacture of the cylinder is guaranteed for a period of **twenty five years** from the date of installation⁴.

Registering the product with Grant Engineering (UK) Limited

Please register your cylinder with Grant Engineering UK Limited **within thirty days of installation**. To do so visit www.grantuk.com and follow the links to the 'Homeowners Zone', where you can register your cylinder for a further **twelve months** guarantee (giving **two years** from the date of installation⁴). This does not affect your statutory rights¹.

If a fault or defect occurs within the manufacturer's guarantee period

If your cylinder should fail within the guarantee period, you must contact Grant Engineering (UK) Limited who will arrange for the repair under the terms of the guarantee, providing that the cylinder has been correctly installed, commissioned and serviced (if the appliance has been installed for more than twelve months) by a competent person and the fault is not due to tampering, misuse or the failure of any external components not supplied by Grant Engineering (UK) Limited, e.g. pipework, etc.

This two year guarantee only applies if the cylinder is registered with Grant Engineering (UK) Limited within thirty days of installation⁴ and is serviced after twelve months³.

In the first instance

Contact your installer or commissioning engineer to ensure that the fault does not lie with the system components or any incorrect setting of the system controls that falls outside of the manufacturer's guarantee otherwise a service charge could result. Grant Engineering (UK) Limited will not be liable for any charges arising from this process.

If a fault covered by the manufacturer's guarantee is found

Ask your installer to contact Grant Engineering (UK) Limited Service Department on +44 (0)1380 736920 who will arrange for a competent service engineer to rectify the fault.

Remember - before you contact Grant Engineering (UK) Limited:

- Ensure the cylinder has been installed, commissioned and serviced by a competent person in accordance with the installation and servicing instructions.
- Ensure the problem is not being caused by the heating system, its controls or any system connected to it.

Free of charge repairs

During the **two year** guarantee period no charge for parts or labour will be made, provided that the cylinder has been installed and commissioned correctly in accordance with the manufacturer's installation and servicing instructions, it was registered with Grant Engineering (UK) Limited within thirty days of installation and⁴, for cylinders over twelve months old, details of annual service is available³.

The following documents must be made available to Grant Engineering (UK) Limited on request:

- Proof of purchase
- Benchmark 'Installation, Commissioning and Service Record Log Book

Chargeable repairs

A charge may be made (if necessary following testing of parts) if the breakdown is due to any fault(s) caused by the plumbing or heating system, external electrics and external components. See 'Extent of manufacturer's guarantee' below.

Extent of the manufacturer's guarantee:

The manufacturer's guarantee does not cover the following:

- If the cylinder has been installed for over **two years**
- If the cylinder has not been installed, commissioned, or serviced by a competent person in accordance with the installation and servicing instructions.
- The serial number has been removed or made illegible.
- Fault(s) due to accidental damage, tampering, unauthorised adjustment, neglect, misuse or operating the cylinder contrary to the manufacturer's installation and servicing instructions.
- Damage due to external causes such as bad weather conditions (flood, storms, lightning, frost, snow or ice), fire, explosion, accident or theft.
- Fault(s) due to incorrectly sized expansion vessel(s), incorrect vessel charge pressure or inadequate expansion on the system.
- Fault(s) caused by external electrics and external components not supplied by Grant Engineering (UK) Limited.
- Cylinder servicing, de-scaling or flushing.
- Checking and replenishing system pressure.
- Pipework, electrical cables and plugs and external controls not supplied by Grant Engineering (UK) Limited.
- Heating system components, such as radiators, pipes, fittings, pumps and valves not supplied by Grant Engineering (UK) Limited.
- Instances where the cylinder has been un-installed and re-installed in another location.
- Use of spare parts not authorised by Grant Engineering (UK) Limited.

Terms of manufacturer's guarantee:

- The Company shall mean Grant Engineering (UK) Limited.
- The cylinder must be installed by a competent installer and in full accordance with the relevant Codes of Practice, Regulations and Legislation in force at the time of installation.
- The cylinder is guaranteed for **two years** from the date of installation⁴, providing that after twelve months the annual service³ has been completed and the cylinder registered with the Company within thirty days of the installation⁴. Any work undertaken must be authorised by the Company and carried out by a competent service engineer.
- The stainless steel (shell) used in the manufacture of the cylinder is guaranteed for a period of **twenty five years** (parts only) from the date of installation⁴. This is subject to the following:
 - The cylinder is operated correctly, in accordance with the installation and servicing instructions.
 - Proof is provided that the connecting system/s has been flushed or chemically cleaned where appropriate (refer to BS 7593) and that the required quantity of a suitable corrosion inhibitor added.
 - Proof of annual servicing (including the checking of any expansion vessels and pressure relief valves) must be provided if and when requested by the Company.
- This guarantee does not cover breakdowns caused by incorrect installation, neglect, misuse, accident or failure to operate the cylinder in accordance with the manufacturer's instructions.
- The cylinder is registered with the Company within thirty days of installation⁴. Failure to do so does not affect your statutory rights¹.
- The balance of the guarantee is transferable providing the installation is serviced prior to the dwelling's new owners taking up residence. Grant Engineering (UK) Limited must be informed of the new owner's details.
- The Company will endeavour to provide prompt service in the unlikely event of a problem occurring, but it cannot be held responsible for any consequences of delay however caused.
- This guarantee applies to Grant Engineering (UK) Limited cylinders purchased and installed on the UK mainland, Isle of Wight, Channel Islands, Isle of Man and Scottish Isles only². Provision of in-guarantee cover elsewhere in the UK is subject to agreement with the Company.
- All claims under this guarantee must be made to the Company prior to any work being undertaken. Invoices for call out/repair work by any third party will not be accepted unless previously authorised by the Company.
- Proof of purchase and date of installation, commissioning and service documents must be provided on request.
- If a replacement cylinder is supplied under the guarantee (due to a manufacturing fault) the product guarantee continues from the installation date of the original cylinder, and **not** from the installation date of the replacement⁴.
- The replacement of a cylinder under this guarantee does include any consequential costs.
- The cylinder must be connected to a mains water supply (installations utilising a private water supply are not covered by this guarantee).
- Breakdown/failure due to lime scale will not be covered by this guarantee.
- The cylinder must not be sited in a location where it may be subjected to frost.

Hard water advice

If you live in a hard water area, protection against scaling in your cylinder must be provided.

You should fit an appropriate scale inhibitor or water softener as any breakdown caused by water scaling is not covered by either the manufacturer's guarantee. Ask your installer for advice.

Foot notes:

1. Your statutory rights entitle you to a one year guarantee period only.
2. The UK mainland consists of England, Scotland and Wales only. Please note that for the purposes of this definition, Northern Ireland and Scilly Isles are not considered part of the UK mainland.
3. We recommend that your cylinder is serviced every twelve months (even when the guarantee has expired) to prolong the lifespan and ensure it is operating safely and efficiently.
4. The guarantee period will commence from the date of installation, unless the installation date is more than six months from the date of purchase, in which case the guarantee period will commence six months from the date of purchase.

APPENDIX A - INSTALLATION, COMMISSIONING AND SERVICE RECORD LOG BOOK

Customer Details

Customer Name	
Customer Address	
TEL No.	

! NOTE !

1. This Log Book is only for use in Great Britain.
2. Please, keep the Log Book in a safe place for future reference.
3. This Log Book is to be completed in full by the competent person(s) who commissioned the equipment and then handed to the customer. When this is done, the Log Book is a commissioning certificate that can be accepted as evidence of compliance with the appropriate Building Regulations.
4. Failure to install and commission this appliance to the manufacturer's instructions may invalidate the guarantee (refer to Section 13 - Guarantee).

Installer & Commissioning Engineer Details

Company Name		Date	
Company Address			
Installer Name		TEL No.	
Registration Details			
Registered operative ID card NO. (if applicable)			

Commissioning Engineer Details (if different)

Company Name		Date	
Company Address			
Installer Name		TEL No.	
Registration Details			
Registered operative ID card NO. (if applicable)			

! NOTE !

IT IS THE RESPONSIBILITY OF THE INSTALLER TO COMPLETE THIS LOGBOOK AND PASS IT ON TO THE CUSTOMER, FAILURE TO DO SO MAY INVALIDATE THE CYLINDER GUARANTEE.

Appliance and Time Control Details

Manufacturer	GRANT UK	Model	
Capacity	Litres	Serial No.	
Type	Unvented		
Time Control	Programmer <input type="checkbox"/> or Time Switch <input type="checkbox"/>		

COMMISSIONING PROCEDURE INFORMATION

Heat Source Primary Settings (indirect heating only)

Is the primary a sealed or open vented system? Sealed Open

What is the primary heat source flow temperature? _____ °C

Incoming Water Supply Information

What is the incoming static cold water pressure at the inlet to the pressure reducing valve? _____ Bar

Has strainer (if fitted) been cleaned of installation debris? YES NO

Has a water scale reducer been fitted? YES NO

What type of scale reducer has been fitted?

Hot Water Cylinder Information

Are combined temperature and pressure relief valve and expansion valve fitted and discharge tested? YES NO

Is primary energy source cut out fitted (normally 2-Port valve)? YES NO

What is the pressure reducing valve setting (if fitted)? _____ Bar

Where is operating pressure reducing valve situated?

Has the expansion vessel or internal air space been checked? YES NO

What is the hot water temperature at the nearest outlet? _____ °C

Hot Water System Information

Does the hot water system comply with the appropriate Building Regulations? YES

Has the system been installed and commissioned in accordance with the manufacturer's instructions? YES

Have you demonstrated the operation of the system controls to the customer? YES

Have you left all the Manufacturer's literature with the customer? YES

Competent Person's Signature		Customer's Signature (To confirm demonstrations of equipment and receipt of appliance instructions)	
------------------------------	--	--	--

SERVICE INTERVAL RECORD

It is recommended that your hot water system is serviced regularly and that your service engineer completed the appropriate Service Interval Record below.

! NOTE !

SERVICE PROVIDER

Before completing the appropriate Service Record below, please ensure you have carried out the service as described in the manufacturer's instructions and in compliance with all relevant codes of practice.

Service 1	Date:
	Engineer name:
	Company name:
	TEL No.
	Comments
	Signature

Service 6	Date:
	Engineer name:
	Company name:
	TEL No.
	Comments
	Signature

Service 2	Date:
	Engineer name:
	Company name:
	TEL No.
	Comments
	Signature

Service 7	Date:
	Engineer name:
	Company name:
	TEL No.
	Comments
	Signature

Service 3	Date:
	Engineer name:
	Company name:
	TEL No.
	Comments
	Signature

Service 8	Date:
	Engineer name:
	Company name:
	TEL No.
	Comments
	Signature

Service 4	Date:
	Engineer name:
	Company name:
	TEL No.
	Comments
	Signature

Service 9	Date:
	Engineer name:
	Company name:
	TEL No.
	Comments
	Signature

Service 5	Date:
	Engineer name:
	Company name:
	TEL No.
	Comments
	Signature

Service 10	Date:
	Engineer name:
	Company name:
	TEL No.
	Comments
	Signature



GRANT ENGINEERING (UK) LIMITED

Frankland Road, Blagrove Industrial Estate, Swindon, SN5 8YG
Tel: +44 (0)1380 736920 Fax: +44 (0)1380 736991
Email: info@grantuk.com www.grantuk.com