



# RENEWABLE PACKAGE SOLUTIONS



HEAT PUMPS • CYLINDERS • SOLAR THERMAL • HEAT EMITTERS

[GRANTUK.COM](http://GRANTUK.COM)

## 2026 is a very special year for us at Grant UK as we celebrate our 30th anniversary.

For three decades, Grant products have been heating Britain's homes with reliable, efficient and innovative heating products. Our product portfolio provides choice for customers, from HVO compatible condensing oil-fired boilers through to our extensive range of renewable appliances, including air source heat pumps, solar thermal systems, hybrid technologies, underfloor heating and aluminium radiators so homes can upgrade their heating to the type of system which best meets their requirements.



Looking back to when we first opened our doors in Salisbury in 1996, it is incredible to see how far we have come. From those early days supplying oil-fired boilers, to now offering a wide choice of renewable heating technologies as well, it's been quite a journey. What has not changed is our commitment to continuous product development, ensuring that every Grant product incorporates the latest technologies and materials to exceed performance and environmental standards.



Alongside our supply of sustainable heating solutions, here at Grant UK we also pride ourselves on supporting our products with first-class customer care, from comprehensive specification assistance when planning an installation through to excellent after-sales support. Consequently, Grant products and services have and continue to be trusted by installers and homeowners alike throughout Great Britain.



We are incredibly proud of what Grant UK has achieved since 1996 and none of this would have been possible without our customers, suppliers and colleagues who have supported us along the way. Your trust and loyalty in our brand have shaped Grant UK into the company it is today.



As we mark this incredible milestone, we are both grateful for the past 30 years, and excited about the future. Here's to the next chapter of working together and continuing to bring sustainable heating to homes across Great Britain.



As we mark this incredible milestone, we are both grateful for the past 30 years, and excited about the future. Here's to the next chapter of working together and continuing to bring sustainable heating to homes across Great Britain.

As we mark this incredible milestone, we are both grateful for the past 30 years, and excited about the future. Here's to the next chapter of working together and continuing to bring sustainable heating to homes across Great Britain.

**Paul Wakefield**  
Managing Director, Grant UK



## CONTENTS

<b>Package Solutions by Grant</b>	<b>4</b>
<b>Aerona Air Source Heat Pumps</b>	<b>8</b>
Aerona <sup>3</sup> R32 range	10
Aerona 290 range	11
Aerona controls	12
VortexAir Hybrid	14
Evolink Smart Hybrid System Hub	16
Aerona <sup>3</sup> technical specifications	18
Aerona 290 technical specifications	19
VortexAir Hybrid technical specifications	20
Evolink Smart Hybrid technical specifications	21
<b>QR2 Cylinders</b>	<b>23</b>
QR2 cylinder range introduction	24
QR2 cylinder range overview	25
QR2 cylinders technical specification	26
<b>Uflex Underfloor Heating</b>	<b>31</b>
Underfloor heating introduction	32
Uflex range	34
Uflex MINI range	36
Uflex overlay board system	37
Controls	38
Controls accessories	40
<b>Afinia Aluminium Radiators</b>	<b>43</b>
Afinia range introduction	44
Afinia technical specifications	45
<b>Grant Solar Thermal</b>	<b>47</b>
Solar thermal introduction	48
Sahara solar range	50
System design	51
Components	52
CombiSOL & WinterSOL	53
<b>Guarantees</b>	<b>54</b>
<b>Product list</b>	<b>56</b>

## PACKAGE SOLUTIONS BY GRANT

Renewable technologies are becoming increasingly popular amongst homeowners who want their property to be heated by a sustainable system. Consumer demand and industry legislation are driving manufacturers to develop products which have less impact on the environment, helping householders to reduce their carbon footprint and to lead greener lifestyles. Consequently, products which offer viable alternatives to traditional fossil fuel heating systems are playing a more prominent role in today's market with householders opting to install cleaner, renewable heating products within their home.

To meet this growing demand for greener heating solutions, Grant has carried out extensive research and development to design, manufacture and supply a comprehensive range of renewable heating technologies. Grant's renewable product portfolio consists of the heat sources and complementary products including a growing range of heat emitters. Not only can installers turn to Grant for a complete range of products but their customers benefit from the peace of mind that comes from sourcing their heating system from one manufacturer.

Grant's renewable technologies all achieve impressive individual efficiencies however, when multiple technologies are combined, the overall efficiency of the complete heating system can be further improved. For example, installing an air source heat pump alongside a high performance cylinder and effective heat emitters can take a home's heating system into a new class of efficiency. All of Grant's products have been developed to complement one another, allowing each product to work at its best when installed alongside the other components within the system helping it to achieve maximum overall efficiency.

Alongside its comprehensive product offering, Grant also provides customer support in the form of design assistance and quotations. The dedicated Grant Renewables Support Team is on hand to assist with the design and sizing requirements for renewable and underfloor heating installations. From answering design queries and assisting with heat loss calculations through to providing full system drawings and complete product specifications, the Renewables Support Team can provide expert advice to help installers and their customers make informed decisions when choosing the right heating solutions for their requirements.

Through its design and quotation services and product supply, Grant delivers complete home heating packages and with so many different products available within its portfolio, there is a package solution to meet almost any home's heating requirements. The diverse range of products available from Grant delivers choice and flexibility for customers, allowing them to select the technologies which best meet their heating needs. From new builds through to retrofits and renovations, Grant's heating products are suitable for installation within a wide range of properties.

**For multiple package solutions, choose Grant.**



## INTRODUCING THE PRODUCTS



### Aerona Air Source Heat Pumps

Grant's Aerona inverter driven air source heat pumps include the award-winning Aerona<sup>3</sup> range and the eye-catching Aerona 290 range. Every Aerona heat pump has exceptional SCOPs (Seasonal Coefficients of Performance), delivering high performance while also having minimal impact on their surroundings both aesthetically and acoustically. Combining efficient operation with quality build, an Aerona air source heat pump is a low carbon, sustainable choice for heating many types of homes.



### Hybrid options

Hybrid technologies are an innovative heating solution that combine the installation of a renewable heat source alongside a fossil fuel appliance, helping hard to heat homes reduce their carbon emissions. The VortexAir Hybrid cleverly combines an Aerona<sup>3</sup> air source heat pump with a low NOx oil-fired Vortex boiler whereas the EvoLink Smart Hybrid System Hub facilitates the installation of a new Aerona heat pump alongside an existing boiler.



### QR 2 Cylinders

The Quick Recovery cylinder range consists of single, twin coil and pre-plumbed variants which are all manufactured to the highest specification to help deliver maximum heat transfer and recovery for effective hot water heating.



### Uflex Underfloor Heating

Grant's wet underfloor heating range, which includes systems suitable for both new build and retrofit situations, effectively and evenly distributes heat into a room while also helping the heat source, such as an air source heat pump, to work at its optimal efficiency.



### Afinia Aluminium Radiators

The Afinia aluminium vertical and horizontal radiators have excellent thermal conductivity which makes them highly responsive and incredibly effective for both low and high temperature systems.



### Sahara Solar Thermal

Available in on-roof, in-roof and flat roof mounting options, Grant's Sahara solar thermal systems offer a clean, sustainable and cost effective low carbon alternative to providing homes with hot water.



## Complete home heating system supplied by Grant UK for self-build home

### INSTALLER

Tom Smith Plumbing and Heating & Greenwave Renewables SW Ltd

### LOCATION

Perranporth, Cornwall

### APPLICATION

Self-build

### PROPERTY

5 bedroom Passiv house

### DATE

Summer 2025

### PRODUCT

- Aerona 290 9kW air source heat pump
- 300ltr QR twin coil hot water cylinder
- 2 collector Grant Solar Thermal System
- Grant Uflex underfloor heating system
- Grant Uflex overlay underfloor heating system

### INSTALLATION INFORMATION

- High levels of insulation
- Almost entirely open loop system
- Heat pump flow temperature set to 45°C
- System achieving uniform temperatures throughout the property of 21°C-22°C

### INSTALLER FEEDBACK

"This was my first time installing the Aerona Smart Controller and it is incredibly intuitive. You can do a lot more with this controller, such as adjusting the heating curve, and this will help us to maximise the efficiency all year round. I've shown the homeowner how to use the controls as part of our handover and using the remote monitoring and management features, I am hoping I can help the system to achieve even greater efficiencies through improved weather compensation and adjustments."

TOM SMITH

### INSTALLER HIGHLIGHTS

"I absolutely love the Aerona 290 heat pump unit," Tom explains. "It is a much better looking heat pump compared to older models and probably one of the best looking heat pumps on the market today. And, with it being Grant's latest generation of heat pump, I was keen to install it at this property in Truro because it met the high standards we were achieving at the build. "



READ THE FULL CASE STUDY

## Aerona 290 replaces gas boiler in 1930's home

### INSTALLER

Ricky Prescott

### LOCATION

Corby, Northamptonshire

### APPLICATION

Retro-fit

### PROPERTY

3 bedroom 1930's end terrace

### DATE

July 2025

### PRODUCT

- Aerona 290 6.5kW air source heat pump
- 180ltr QR single coil hot water cylinder
- Aerona Smart Controller

### INSTALLATION INFORMATION

- Gas combi boiler replacement
- Average heat load: 76W/m<sup>2</sup>
- Design outdoor weather temperature: -2.4°C
- Indoor room temperatures: 18°C - 21°C
- Heat pump capacity at 45°C: 6.61kW

### INSTALLER FEEDBACK

"The controller is very easy to use. The user interface of a heat pump controller is a significant part of a heat pump installation so having good controls is important. The Aerona Smart Controller's display is clear and it's useful being able to easily see what is on within the heat pump system and what is not. I will also be using the remote monitoring feature through the ecoNet app later in the year, when the outside temperatures start to cool down, to ensure the system is operating as efficiently as it can"

RICKY PRESCOTT

### INSTALLER HIGHLIGHTS

"Rob Dyer, one of Grant UK's Technical Sales Support Engineers, came and helped me with the system set-up once we were ready to commission," comments Ricky. "With both the heat pump and controller being new products for me, it was useful to have this onsite technical support to just ensure I had everything set up as required. The installation was completed at the beginning of the summer when we had very warm weather but I am looking forward to monitoring its performance and finding ways to ensure it's working at its optimum efficiency."



READ THE FULL CASE STUDY



A black Grant AERONA air source heat pump unit is mounted on a concrete pad against a brick wall. The unit features a large, black, diamond-patterned grille on its front. To the right of the unit is a window with a dark frame. The background shows a brick wall and a concrete walkway. In the foreground, there is green grass and some purple flowers.





## AERONA AIR SOURCE HEAT PUMPS

Grant's air-to-water heat pumps are highly efficient and provide homeowners with a low-carbon solution for heating their homes and reducing their dependency on fossil fuels. The AERONA<sup>3</sup> air source heat pumps, which use R32 refrigerant, are compact in size, have excellent SCOPs and are quiet in operation. Meanwhile, the AERONA 290 heat pumps use the more sustainable R290 refrigerant and are an even more environmentally friendly heating solution, combining modern aesthetics with high performances and featuring Grant's latest heat pump technology.

## AERONA<sup>3</sup> R32 RANGE

Consisting of four single phase models – 6kW, 10kW, 13kW and 17kW – the Aerona<sup>3</sup> R32 heat pumps provide heating and hot water for properties. Each unit operates at high efficiencies even when the external temperatures are low, making for a cost-effective renewable alternative to traditional off-gas heating methods. Furthermore, the Aerona<sup>3</sup> heat pumps have minimal impact on their surroundings being compact in size and quiet in operation.

### FEATURES

-  Outputs from 6kW up to 17kW
-  Global Warming Potential of 675 (70% less than R410A refrigerant)
-  In-built weather compensation
-  In-built frost protection
-  Connect & Notify Approved (6kW, 10kW and 13kW models)



### How quiet is a heat pump?

Our short video features audio footage from an Aerona<sup>3</sup> 13kW air source heat pump and compares this with other common household appliances. Scan the QR code below to watch the video or head to our YouTube channel [youtube.com/myGrantUK](https://www.youtube.com/myGrantUK).







\*When installed by a G1 Installer. Subject to full T&C's.

## AERONA 290 RANGE

Five single phase models are available in the Aerona 290 range including three single fan units – 4kW, 6.5kW and 9kW – and two twin fan units – 12kW and 15.5kW. Each Aerona 290 heat pump, which has been rated at -5°C air temperature and 55°C water flow temperature, uses the energy efficient R290 refrigerant which has excellent thermodynamic properties. With a stylish, durable black powder coated casing, the Aerona 290 is an even more sustainable heat pump that is designed to effectively heat homes and their hot water.

### FEATURES

-  Outputs from 4kW up to 15.5kW
-  Global Warming Potential of 3, significantly lower than other heat pump refrigerants
-  Remote monitoring and management functionality using the Aerona Smart Controller
-  R290 safety features
-  Connect & Notify approved (all models)



### What is R290 refrigerant?

R290 refrigerant, which is more commonly known as Propane, is a natural refrigerant gas which is non-toxic, odourless and is less damaging to the earth's atmosphere compared to other refrigerants.

Scan the QR code to visit our Blog to learn more about R290 refrigerant and the benefits it offers to heat pumps.



\*When installed by a G1 Installer. Subject to full T&C's.

# AERONA<sup>3</sup> REMOTE CONTROLLER



The AERONA<sup>3</sup> Remote Controller, which is compatible with AERONA<sup>3</sup> heat pump models only, is a compact white-cased wall-mounted unit. With a simple interface, the AERONA<sup>3</sup> Remote Controller provides installers and end-users with access to the heat pump's core parameters to set, view and adjust these as required. Homeowners can also keep informed about the operating status of their heat pump by viewing the symbols and icons shown on the LCD display screen.

 ORIGINAL AERONA LCD REMOTE CONTROLLER

 PROVIDES ACCESS TO CORE HEAT PUMP AND SYSTEM PARAMETERS

 EASY TO READ SYMBOLS TO INDICATE OPERATING MODE

 PROVIDES REAL-TIME OPERATING DATA PARAMETERS

Also available on the Grant UK YouTube channel is a video playlist on the AERONA<sup>3</sup> remote controller.

Including videos on programming through to fault finding, the playlist is a great resource if you have an AERONA remote controller installed in your home.

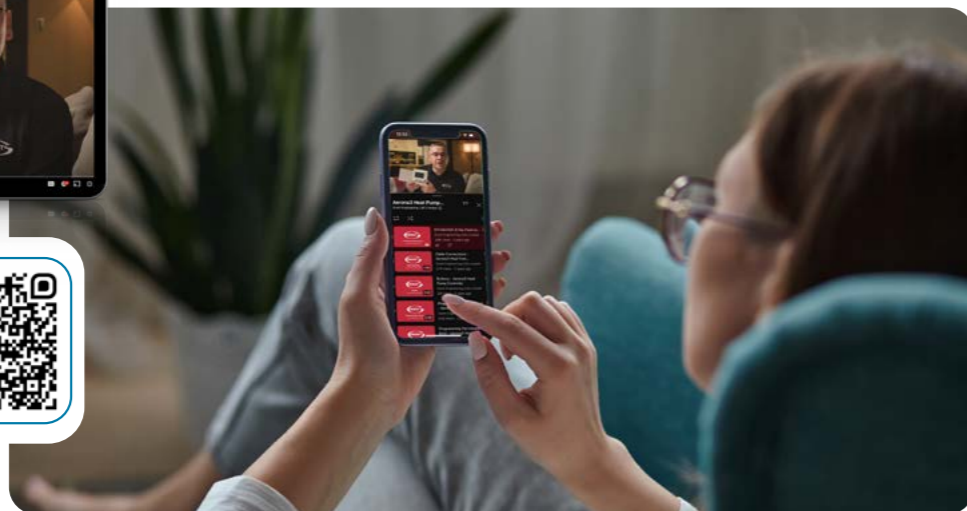

# AERONA SMART CONTROLLER



Designed for installation with both AERONA<sup>3</sup> and AERONA 290 heat pumps, the AERONA Smart Controller is intuitive and stylish. Using advanced controller technology, the AERONA Smart Controller can help customers maximise the efficiency of their Grant heat pump system with weather and load compensation as well as heating curve configuration. The 4.5" colour touchscreen display is simple to navigate and, when installed with the AERONA WiFi hub, the AERONA Smart Controller can be remotely accessed using an app or web-based portal.

 INTUITIVE

 3 HEATING ZONES+DHW

 EASY SET UP

 WEB BASED MONITORING & CONTROL

 HEATING CURVE SELECTION

 7 DAY PROGRAMMING

## YouTube

A playlist of handy videos about the AERONA Smart Controller is available to watch on Grant UK's YouTube Channel. The videos provide an overview of this intuitive heat pump controller as well as sharing step-by-step demonstrations on how to set the core settings.

This playlist also includes videos explaining the controller display icons, how to adjust the circuit temperature and heating schedule, setting up an ecoNET account and much more.

Scan to view or head to [youtube.com/MyGrantUK](https://youtube.com/MyGrantUK) to subscribe



## VORTEXAIR HYBRID

The Grant VortexAir Hybrid couples together a Grant Vortex condensing low NOx oil-fired boiler with an Aerona<sup>3</sup> air source heat pump. The VortexAir Hybrid cleverly combines a traditional fossil fuel source with the green advantage of a heat pump, providing a renewable solution to boiler replacements.

Using just a single flow and return connection into the house, the VortexAir Hybrid incorporates a 17kW Aerona<sup>3</sup> R32 air source heat pump with a 15/26kW low NOx Vortex oil boiler. This unique arrangement allows the oil boiler to be installed first as a stand-alone unit, either internally or externally, replacing an older oil-fired appliance and providing immediate heat and hot water for the householder.

The heat pump is then installed externally and coupled via a simple plumbing and electrical arrangement to the oil boiler. The heat pump can be installed at the same time as the boiler or it can be fitted as part of a two-stage installation which is hugely beneficial in distress purchase situations. When a quick replacement heating solution is required, the VortexAir enables householders to rapidly restore their home heating with the boiler and then later incorporate an alternative fuel source with the heat pump element.

The Grant Vortex oil boiler utilised within the hybrid is renowned for its high efficiency, reliability and ultra low NOx emissions. This cleaner oil-fired boiler technology combined with the green credentials of the Aerona<sup>3</sup> heat pump results in an innovative hybrid solution which delivers the best of both worlds. Homeowners can introduce renewable technology into their home while also having the peace of mind that comes with the back-up heating provided via the boiler.

### Models

HPIDAIR1526

VortexAir 15–26kW Oil Boiler & 17kW R32

Heat Pump Hybrid

### Features

- Easy to install and maintain
- Boiler works as a stand-alone unit and can be installed internally or externally
- Heat pump is always fitted externally
- Boiler can be used to provide heat before the heat pump is fitted
- Meter ready, fully pre-plumbed and wired
- Option to manually switch between hybrid and oil
- Low level balanced flue supplied as standard
- Optional plume diverter kit available (purchase separately)



5 year guarantee\*



A+++ Air Source Heat Pump EN14825:55HEE W45



A



MCS CERTIFIED



NATIONAL ACS & HEAT PUMP AWARDS 2022 WINNER



## MAXIMISE SYSTEM EFFICIENCY

The Grant VortexAir Hybrid has been designed to maximise overall system efficiency with the use of an advanced control system. Automatically monitoring the ambient air temperature, the unit will seamlessly switch to the most effective heating mode, whether that be heat pump, oil, or a combination of both.

There are four unique operating modes incorporated into the Grant VortexAir's controller (detailed right). Working in this way, the heat pump is able to contribute to the heat requirement of the house for longer, thereby reducing running costs.

The graph below shows an example of how the operating modes seamlessly change depending upon the ambient air temperature and assumed heat loss for the property.

**MODE 1**  
Heat Pump only at lower flow temperatures between 35°C – 55°C for space heating (DHW)

**MODE 2**  
Heat Pump and Oil Boiler combined at lower flow temperatures between 40°C – 50°C

**MODE 3**  
Heat Pump and Oil Boiler combined at higher flow temperatures up to 70°C

**MODE 4**  
Oil Boiler with higher flow temperatures up to 70°C and little heat pump contribution

### Example of operating modes for a property with a 18kW assumed heat loss

Ambient Design Temp -5°C  
Flow Temp 45°C  
Radiator Design Temp 70°C

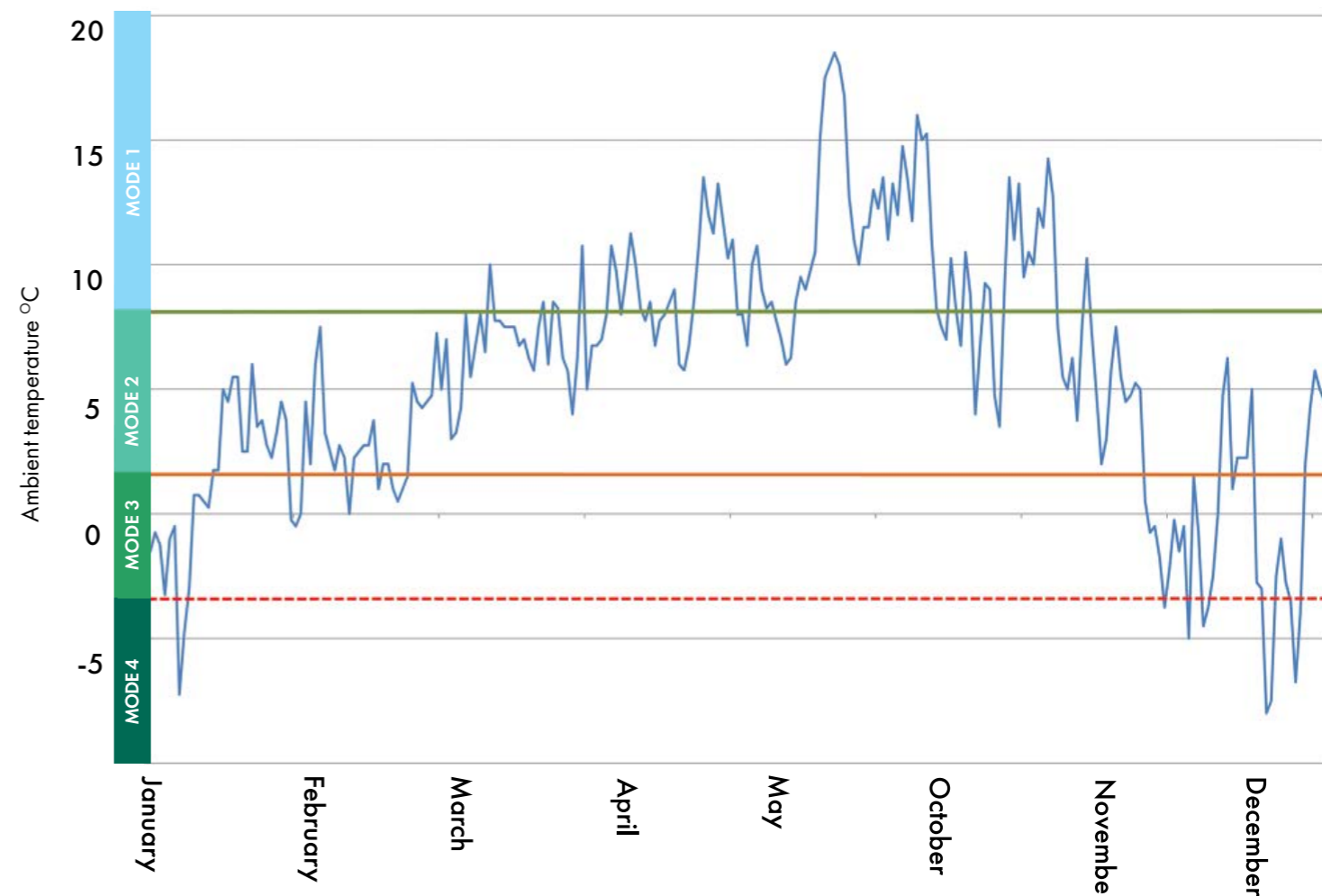

\*When installed by a G1 Installer. Subject to full T&C's.

# EVOLINK SMART HYBRID SYSTEM HUB

The EvoLink Smart Hybrid System Hub is a compact wall-mounted unit that allows homeowners to have an Aerona<sup>3</sup> or Aerona 290 air source heat pump installed with most existing domestic heating systems, allowing renewable energy to be incorporated while keeping the existing boiler as a supplementary heat source.







With the EvoLink Smart, the heat pump will supply as much of the heat energy to the system as possible. If the boiler output flow is required to satisfy either the space heating or hot water load, the EvoLink Smart will mix the boiler flow with the heat pump flow to achieve and maintain the required flow temperature. Once the return temperature rises to a point where the heat pump will switch off, the amount of mixing will reduce and the boiler may be switched off, to ensure the heat pump remains operating.

## Models

EVOLINKSMART

EvoLink Smart Hybrid System Hub

## Features

-  Immediately reduce a home's carbon footprint
-  Allows installation of a Grant heat pump alongside an existing heating system
-  Compact size – only 350mm wide x 350mm high x 179mm deep
-  Suitable for use with most gas, oil, LPG and modulating Biomass boilers
-  Cleverly uses the boiler to add only the additional heat as required using smart technology
-  Uses Grant Aerona Smart Controller without the need for additional controls
-  Compatible with existing 'S' and 'Y' plan underfloor heating systems

For harder to heat homes, where a heat pump alone may be unable to fulfil a property's entire heat demand, the EvoLink Smart provides a solution to combine a low carbon air source heat pump with a traditional fossil fuel heating system, including oil, gas, LPG and modulating biomass boilers. The EvoLink Smart, Grant's second generation hybrid system hub, is designed to maximise the heat pump's usage only using the existing boiler to either assist the heat pump in meeting the heating demand when required, or to provide the total heat required under the coldest conditions, to help households reduce their dependency on fossil fuels.

The EvoLink Smart unit, suitable for internal installation only, houses the hydraulics, including a combined mixing tank, boiler flow and return connections, heat pump flow and system flow connections, mixing PWM pump and temperature sensors, and enables installers to fit a new Aerona 290 or Aerona<sup>3</sup> heat pump to an existing heating system. Compatible with S-plan and Y-plan control systems and sealed systems, the EvoLink Smart is suitable for use with boilers systems which have a space heating output up to 28kW.

The EvoLink Smart is designed to be controlled by the Grant Aerona Smart Controller that is also controlling the heat pump. Together, the Aerona Smart Controller and EvoLink Smart will operate the air source heat pump as the main heat source on the system with the existing boiler serving as the additional heat source that will be used when the heat pump alone is unable to fulfil the demand.

Meanwhile, for the hot water load, the EvoLink Smart provides an automatic hot water priority function and again the control system will use the heat pump to achieve the target flow temperature for the hot water cylinder with the boiler only operated when the heat pump alone cannot achieve it.



\*Subject to full T&C's.

# EVOLINK SMART

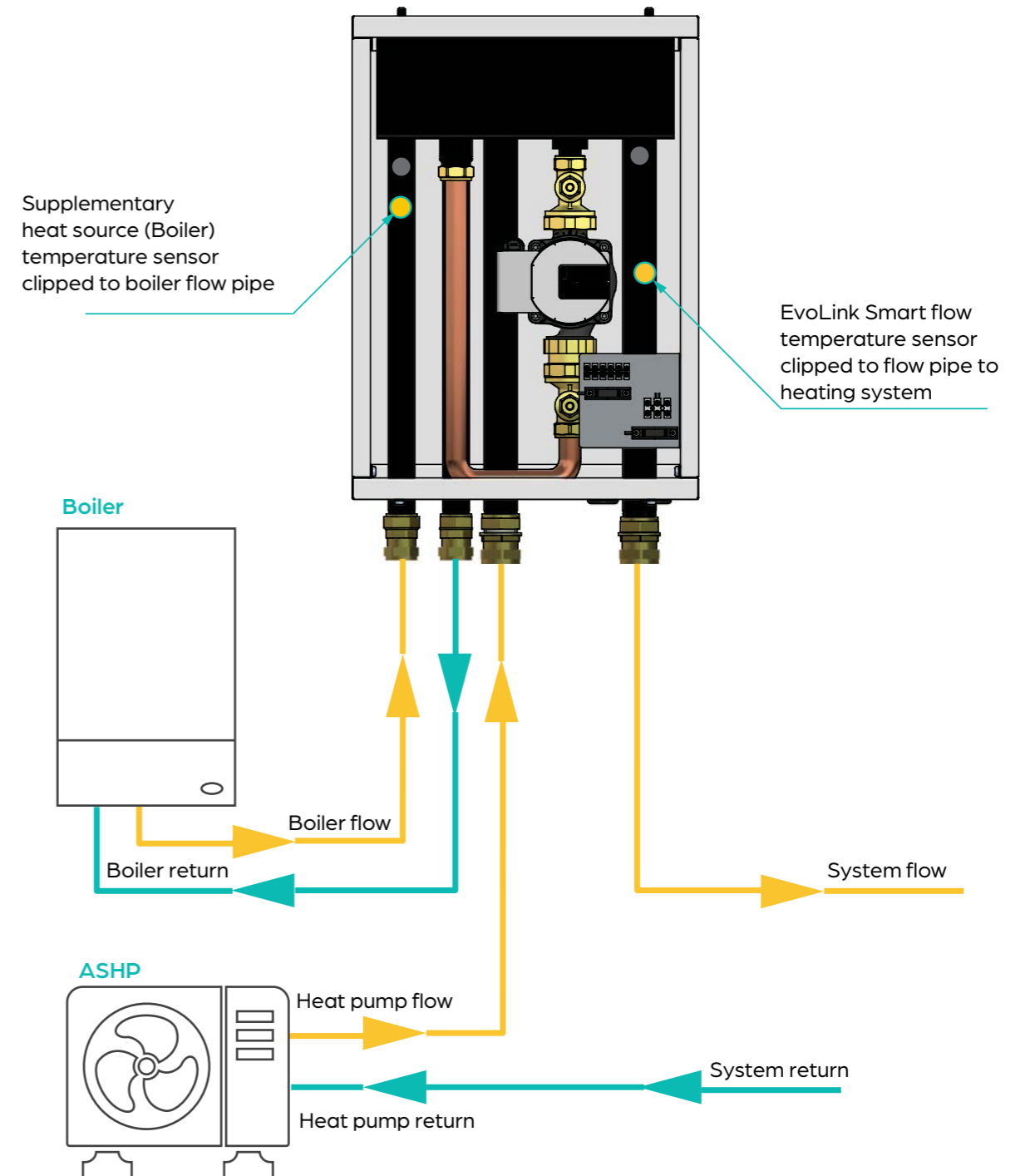

# AERONA<sup>3</sup> R32 TECHNICAL SPECIFICATIONS

		HPID6R32	HPID10R32	HPID13R32	HPID17R32
ErP Rating <sup>1</sup>	Heating	A+++	A+++	A+++	A+++
Height (mm)		675	882	1418	1418
Width (mm)		898	874	1024	1024
Depth (mm)		379.4	405	403	403
Weight (kg)	Empty	51	70	99	118
	Full	52.8	71.8	101	120
Heating capacity (kW) <sup>2</sup>		6.92	11.1	13.6	18.0
COP <sup>2</sup>		4.91	5.28	5.25	4.79
SCOP <sup>2</sup> average climate conditions		4.61	5.20	5.40	4.54
Refrigerant (R32) (kg)		0.80	1.55	2.20	2.80
Power supply		~230V 1ph 50Hz			
Water connections (BSPF)		¾"	1"	1 ¼"	1 ¼"
Min/ Max operating ambient temperature (°C)		-20/43	-20/43	-20/43	-20/43
Sound power level dB(A) <sup>3</sup>		65.2	64	60.8	61.6
Sound pressure level at 1m - external (dB(A))(Q=1)		54.2	53	49.8	50.6

<sup>1</sup> Low temperature: 35°C flow (heating). EN14825: SSHEE W45

<sup>2</sup> BS EN 14511 - air 7°C/ Water 35°C

<sup>3</sup> BS EN ISO 3743-1:2010

HPID6R32

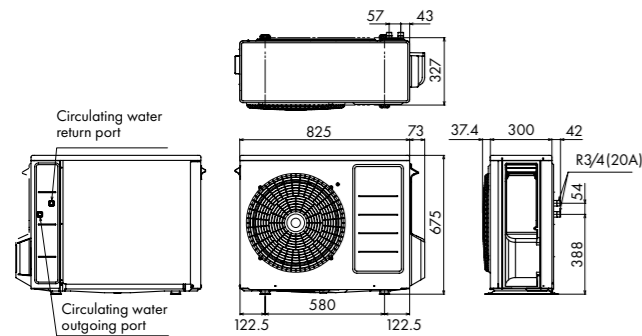

HPID10R32

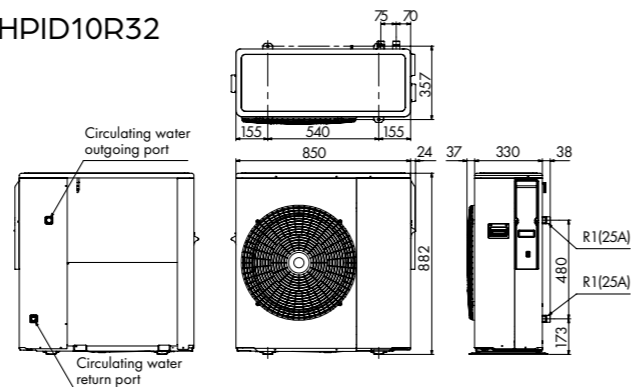

HPID13R32 & HPID17R32

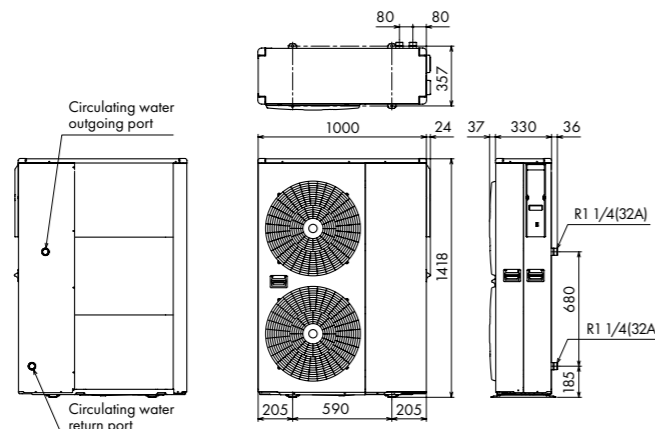

# AERONA 290 TECHNICAL SPECIFICATIONS

		HPR2904	HPR29065	HPR2909	HPR29012	HPR290155
ErP Rating <sup>1</sup>	Heating	A+++	A+++	A+++	A+++	A+++
Height (mm)		803	854	854	1365	1365
Width (mm)		1155	1223	1223	1155	1155
Depth (mm)		422	461	461	425	425
Weight (kg)	Empty	99	115	131	153	180
	Full	102	117	133	157	184
Heating capacity (kW) <sup>2</sup>		4.09	7.62	9.38	12.18	16.16
COP <sup>2</sup>		4.99	4.95	4.93	4.81	4.72
SCOP <sup>2</sup> average climate conditions		5.00	5.08	4.74	4.74	4.56
Refrigerant (R290) (kg)		0.61	0.83	1.00	1.20	1.65
Power supply		~230V 1ph 50Hz				
Water connections (BSP)		1"	1"	1"	1"	1"
Min/ Max operating ambient temperature (°C)		-25 to 35	-25 to 35	-25 to 35	-25 to 35	-25 to 35
Sound power level dB(A) <sup>3</sup>		48	52	54	52	53
Sound pressure level at 1m - external (dB(A))(Q=2)		40	44	46	44	45

<sup>1</sup> Low temperature: 35°C flow (heating). EN14825: SSHEE W45

<sup>2</sup> BS EN 14511 - air 7°C/ Water 35°C

<sup>3</sup> BS EN 12102-1

HPR2904

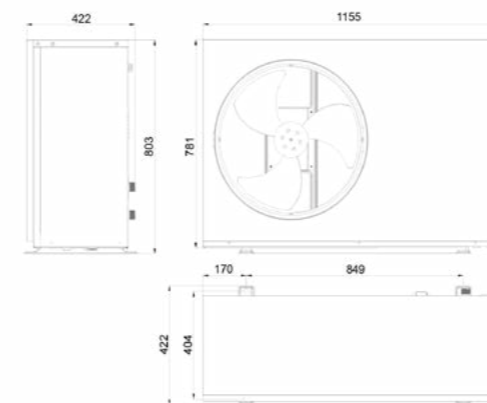

HPR29065  
HPR2909

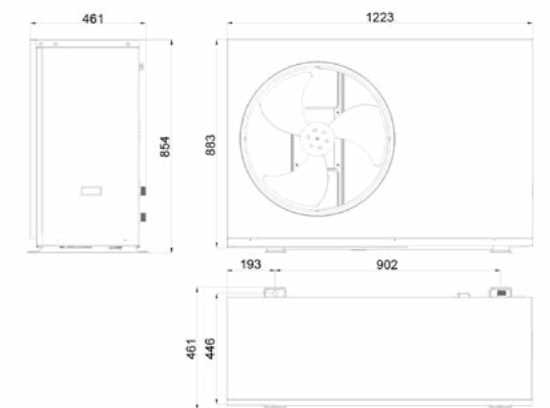

HPR29012  
HPR290155

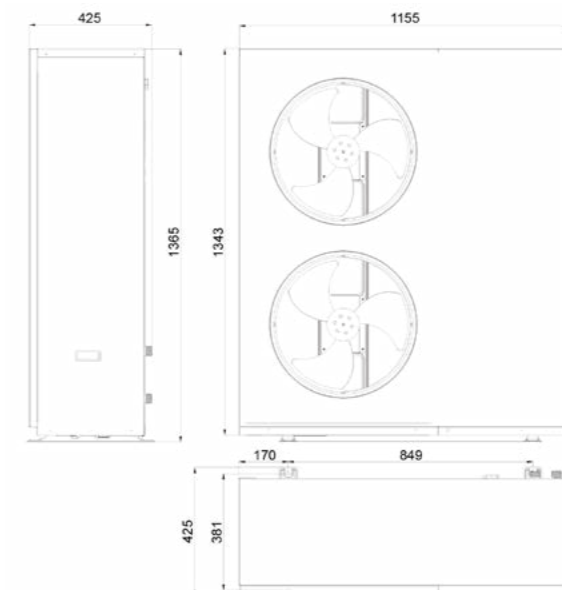

# VORTEXAIR TECHNICAL SPECIFICATIONS

			HPIDAIR1526
ErP Rating <sup>1</sup>	Heat Pump	Heating	A+++
	Boiler	Heating	A
Height (mm)			1420
Width (mm)			2047
Depth (mm)			525
Weight (kg)	Heat Pump	Empty	118
	Boiler	Empty	151
	Combined	Empty	269
Boiler output (kW)			21-26
Heat pump capacity (kW) <sup>2</sup>			18.0
Heat pump power input (kW) <sup>2</sup>			3.76
Heat pump COP <sup>2</sup>			4.79
Heat pump SCOP average climate conditions <sup>2</sup>			4.54
Heat pump refrigerant (R32) (kg)			2.80
Heat pump power supply			~230V 1ph 50Hz
Heat pump water connections (BSPF)			1 1/4"
Heat pump min/ max operating temperatures Air (°C)			-20/43
Heat pump sound power level dB(A) <sup>3</sup>			61.6
Heat pump sound pressure level at 1m - external (dB(A)) (Q=1)			50.6

<sup>1</sup> Low temperature: 35°C flow (heating), EN14825: SSHEE W45

<sup>2</sup> BS EN 14511 - air 7°C/ Water 35°C

<sup>3</sup> BS EN ISO 3743-1:2010

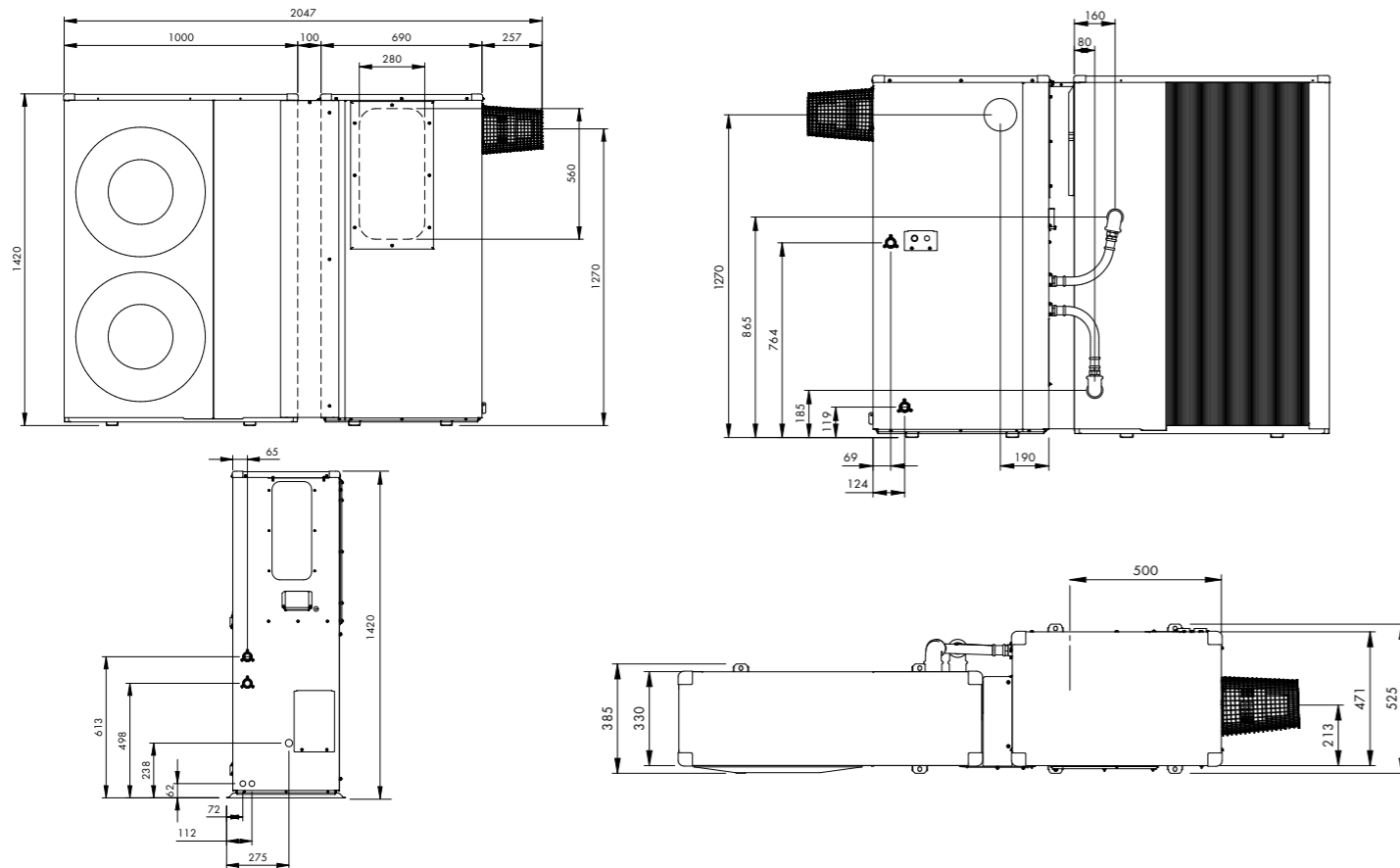

# EVOLINK SMART TECHNICAL SPECIFICATIONS

Weight - empty	18.2kg
Weight - full	20.8kg
Water content	2.6 litres
Connections - heating system	1" BSP Male Iron
Connections - heat pump	1" BSP Male Iron
Connections - boiler (flow & return)	3/4" BSP Male Iron

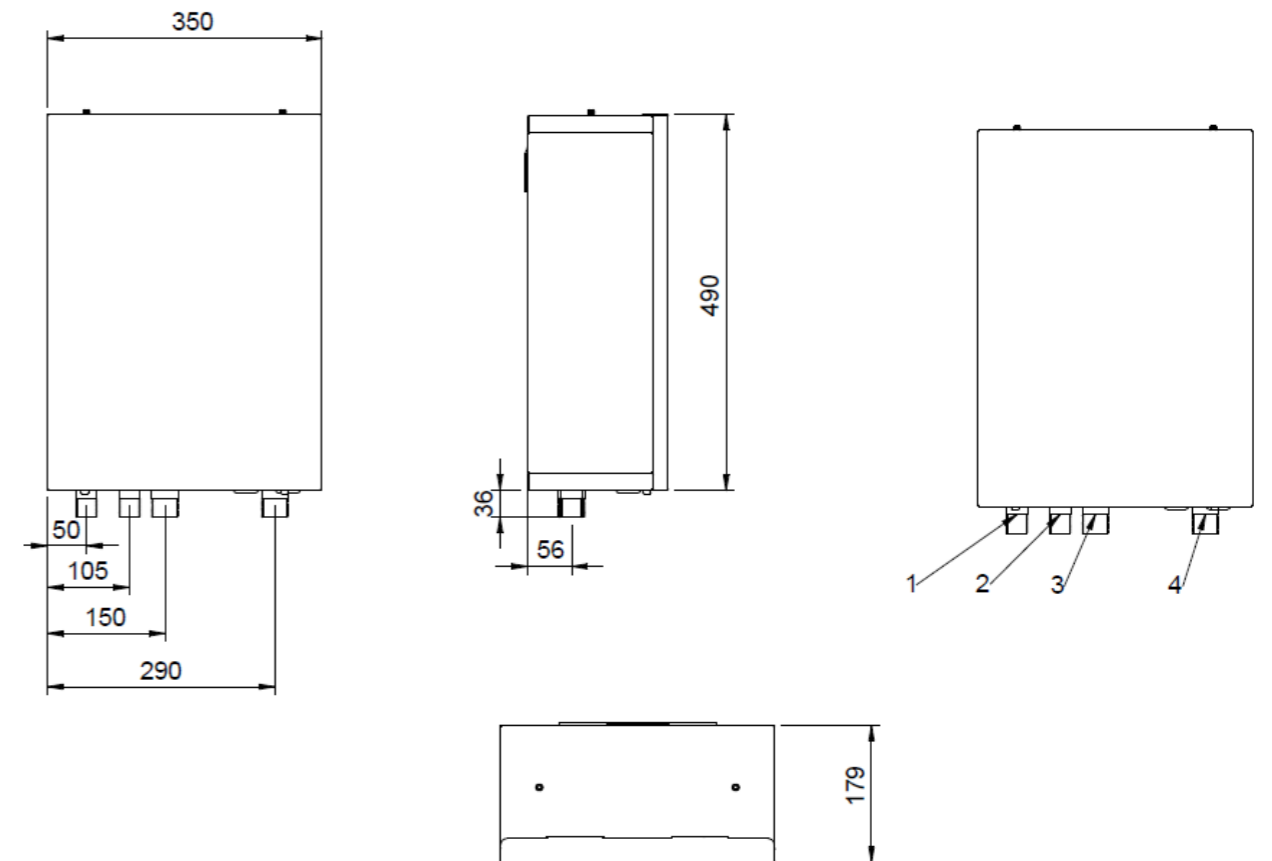

## CONNECTIONS

No.	Connections	Size
1	Boiler flow	22mm
2	Boiler return	22mm
3	Heat pump flow	28mm
4	System flow	28mm

## QR2 HOT WATER STORAGE CYLINDERS

The Quick Recovery 2 (QR2) cylinder range comprises of high efficiency indirect hot water solutions which can partner with all of Grant's heat source appliances. Each model can complement traditional and renewable technologies, providing an ecofriendly, reliable and energy efficient solution for a home's hot water requirements. All of the QR2 cylinder models are suitable for use as unvented or open vented cylinders, and are designed to suit multiple installation scenarios, making them Grant's most versatile range of hot water cylinders.



# INTRODUCTION TO THE QR2 RANGE

## Universal Compatibility

All of the QR2 cylinders are suitable for installation alongside boilers and air source heat pumps meaning they can be fitted as part of a package with either a Vortex oil boiler or an Aerona air source heat pump. When an installation involves more than one heat source, such as a heat pump and solar thermal system, both systems can be combined using one of the twin coil QR solar cylinder models. This hot water cylinder range is, therefore, incredibly adaptable with each model being suitable for multiple applications which can make specification very straightforward.

## Excellent Performance

The QR2 cylinder range is Grant's most efficient generation of cylinders featuring ErP 'B' and 'C' rated models, boasting fast heat-up times and excellent standing heat losses.

## Clever Design

Each QR2 cylinder incorporates a number of design features which make for an easier installation. The connections are all compression fittings and the pre-plumbed models include a fully integrated EP001 wiring centre or the Aerona Smart Controller wiring centre and touchscreen display factory fitted on the Smart pre-plumbed versions. A plinth is available as an optional accessory – this plinth (which is suitable for installation with all the cylinders, excluding the Integrated model) allows the pipework to be plumbed in the floor and then the cylinder can be mounted on top with just elbows required to pipe the unit up, making for a tidy installation finish. An optional cylinder stand is also available to facilitate installing a cylinder above the Grant 50ltr internal volumiser. With these features and the cylinders' streamlined design, the range successfully combines function and aesthetics.

## Quality build

The QR2 cylinder range is produced to the highest standards so that each model delivers maximum heat transfer and recovery. They are manufactured using a high quality duplex stainless steel inner shell and the large internal coils are made from 22mm stainless steel tubing. Each cylinder is also insulated with 50mm of CFC/HCFC free, fire retardant, polyurethane foam which is injected between the stainless steel cylinder and the galvanised outer casing. This high level of insulation ensures low standing heat losses and outstanding efficiency. All Grant QR cylinders have a 25 year guarantee on their shell, reflecting their exceptional build quality and providing ultimate peace of mind.

\*subject to full T&C's

## Features

- 25 year material guarantee on cylinder shell (subject to full Terms and Conditions)
- 22mm stainless steel compression bosses supplied with polypropylene caps for protection during transit (Pre-plumbed and Integrated Cylinders have 28mm compression fittings supplied in the kit)
- No anode required
- Factory-fitted 3kW immersion heater
- Fast recovery stainless steel coils
- Labelled tappings and connections
- Factory fitted temperature and pressure relief valve
- Supplied with an unvented kit as standard including expansion vessel, inlet manifold, tundish, 2-port motorised valve and dual thermostat
- Quality external finish with organic Estectic Tex paint
- Global Warming Potential (GWP) of 3.1
- Ozone Depletion Potential (ODP) of 0



## QUICK RECOVERY MODELS

The Quick Recovery unvented, indirect mains pressure cylinders include QR2 single coil models and QR twin coil variants. Available in sizes from 150 litres up to 300 litres, these cylinders are high performing units which provide homes with an efficient, reliable hot water storage solution. The range includes pre-plumbed models which make for a quicker and easier installation as well as slimline units which are ideally suited for properties where space is at a premium. Internal and external volumisers are also available to complement the cylinder range.

### Pre-Plumbed Models (with EP001 wiring centre)

Three QR2 Pre-Plumbed cylinder models are supplied with the EP001 Wiring Centre and are compatible with Aerona<sup>3</sup> heat pump models.

These are supplied with the following:

- Factory-fitted, pre-wired EP001 wiring centre
- Factory-fitted Digital dual thermostat and immersion heat timer
- Factory-fitted cold water inlet pipework
- Potable water expansion vessel for the cylinder
- Factory-fitted primary system pipework including a built-in filling loop, system pressure gauge, automatic system bypass, a 2-port zone valve for the hot water and two 2-port zone valves for two heating zones

### Smart Pre-Plumbed Models (with Aerona Smart Controller)

Four QR2 Smart Pre-Plumbed cylinder models are available which are supplied with the Aerona Smart Controller and are compatible with both the Aerona<sup>3</sup> and Aerona 290 heat pump models.

These are supplied with the following:

- Factory-fitted pre-wired controls with Aerona Smart Controller display, wiring centre, digital dual thermostat and immersion heat timer. The Aerona Smart Controller touchscreen display is supplied fitted to the cylinder but this can be removed and located in another room if preferred
- Factory-fitted cold water inlet pipework
- Potable water expansion vessel for the cylinder
- Factory-fitted primary system pipework including a built-in filling loop, system pressure gauge, automatic system bypass, a 2-port zone valve for the hot water and two 2-port zone valves for two heating zones



# QUICK RECOVERY CYLINDER RANGE

## Single Coil

Model	Actual Capacity (ltrs)	ErP Rating	Coil rating primary (kW)	Standing heat loss (kW/24hrs)	Overall Height (mm)	Overall Diameter (mm)	Weight empty (kg)	Weight full (kg)
QR2SC150	138	B	44.70	1.15	1175	561	36.5	174.5
QR2SC180	168	B	42.14	1.21	1354	561	39	207
QR2SC210	199	B	39.58	1.41	1541	561	44	242
QR2SC250	238	B	36.17	1.54	1791	561	49	287
QR2SC300	288	C	31.90	1.81	2103	561	54.5	342

## Single Coil | Slimline

Model	Actual Capacity (ltrs)	ErP Rating	Coil rating primary (kW)	Standing heat loss (kW/24hrs)	Overall Height (mm)	Overall Diameter (mm)	Weight empty (kg)	Weight full (kg)
QR2SC150SL	140	B	37.50	1.24	1567	481	37	179
QR2SC180SL	170	B	36.55	1.40	1839	481	44	214
QR2SC210SL	200	C	35.60	1.57	2110	481	49	248.5

## Single Coil | Pre Plumbed

Model	Actual Capacity (ltrs)	ErP Rating	Coil rating primary (kW)	Standing heat loss (kW/24hrs)	Overall Height (mm)	Overall Diameter (mm)	Weight empty (kg)	Weight full (kg)
QR2SC210PP	198	B	39.58	1.41	1541	561	56.5	245.5
QR2SC250PP	238	B	36.17	1.54	1792	561	61.5	299.5
QR2SC300PP	288	C	31.90	1.81	2103	561	67	354.5

## Single Coil | Smart Pre Plumbed

Model	Actual Capacity (ltrs)	ErP Rating	Coil rating primary (kW)	Standing heat loss (kW/24hrs)	Overall Height (mm)	Overall Diameter (mm)	Weight empty (kg)	Weight full (kg)
QR2SMART180PP	168	B	42.14	1.21	1354	561	46	214
QR2SMART210PP	198	B	39.58	1.41	1541	561	51	249
QR2SMART250PP	238	B	36.17	1.54	1792	561	56	294
QR2SMART300PP	288	C	31.90	1.81	2103	561	61.5	349

## Single Coil | Integrated

Model	Actual Capacity (ltrs)	ErP Rating	Coil rating primary (kW)	Standing heat loss (kW/24hrs)	Overall Height (mm)	Overall Width (mm)	Overall Depth (mm)	Weight empty (kg)	Weight full (kg)
QRINTSC210	197	C	32.0	1.79	1855	594	727*	139	375

## Twin Coil

Model	Actual Capacity (ltrs)	ErP Rating	Coil rating primary (kW)	Solar Coil (kW)	Standing heat loss (kW/24hrs)	Overall Height (mm)	Overall Diameter (mm)	Weight empty (kg)	Weight full (kg)
QR2TC210	192	C	32.0	19.7	1.79	1490	550	59	251
QR2TC250	233	C	32.0	20.7	2.02	1741	550	65	298
QR2TC300	284	C	34.0	22.1	2.24	2054	550	77	361

\*includes 100mm spacer channel (627mm without spacer)

# TECHNICAL SPECIFICATIONS

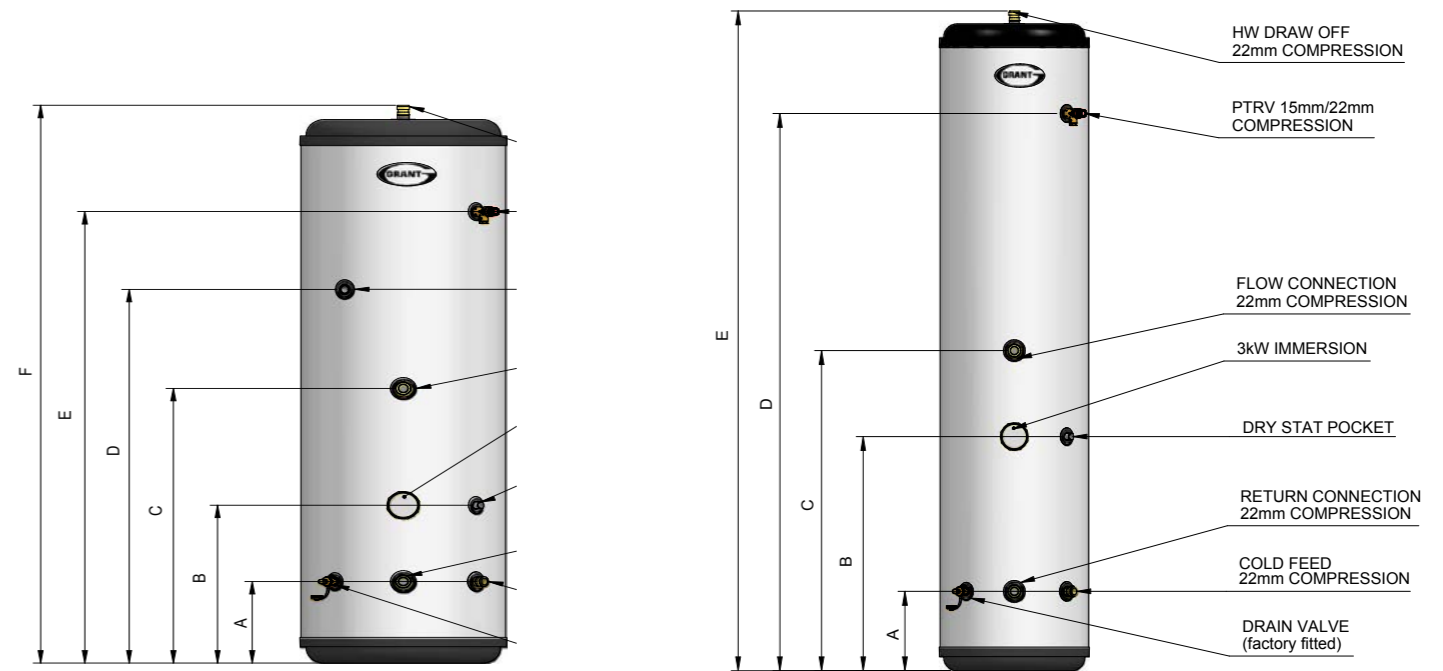

## Single Coil

Dimensions (mm)	150L	180L	210L	250L	300L
A	263	262	262	262	262
B	512	507	507	507	507
C	884	882	882	882	882
D	-	-	-	1200	1512
E	884	1013	1200	1450	1762
F	1175	1354	1541	1791	2103

## Single Coil | Slimline

Dimensions (mm)	150L	180L	210L
A	254	254	254
B	749	749	749
C	1024	1024	1024
D	1240	1511	1783
E	1567	1839	2110

## Twin Coil

Dimensions (mm)	210L	250L	300L
A	1150	1401	1601
B	1267	1518	1831
C	1467	1717	2030
D	1490	1741	2054
Diameter	550	550	550

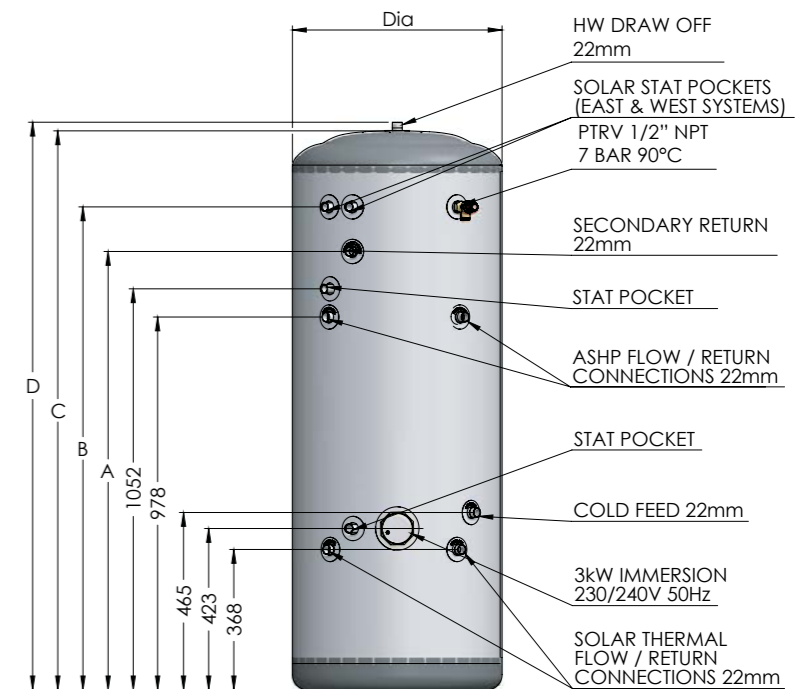

# QUICK RECOVERY CYLINDER RANGE

# TECHNICAL SPECIFICATIONS

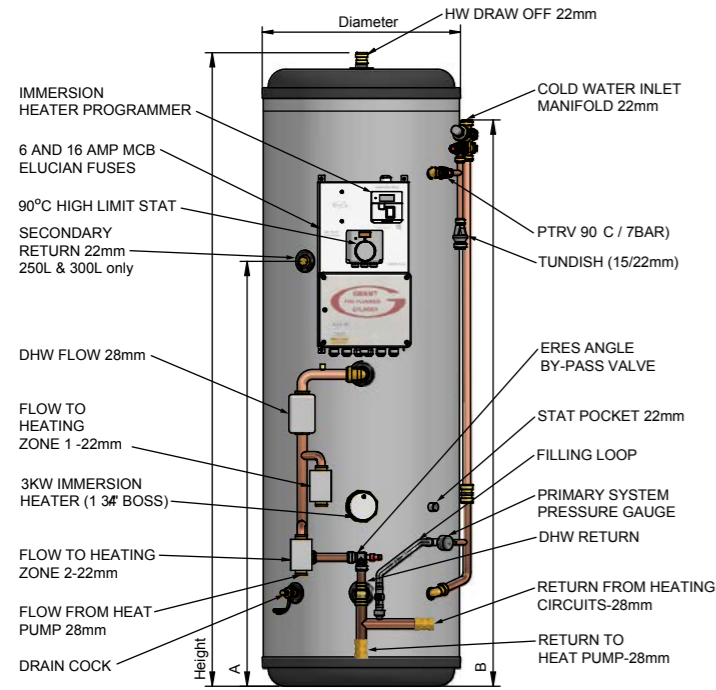

## Single Coil | Pre-Plumbed

Dimensions (mm)	210L	250L	300L
A*	-	1200	1511
B	1354	1792	2103
Height	1541	1792	2103
Diameter	561	561	561

\*Secondary return on 250 and 300 litre models only

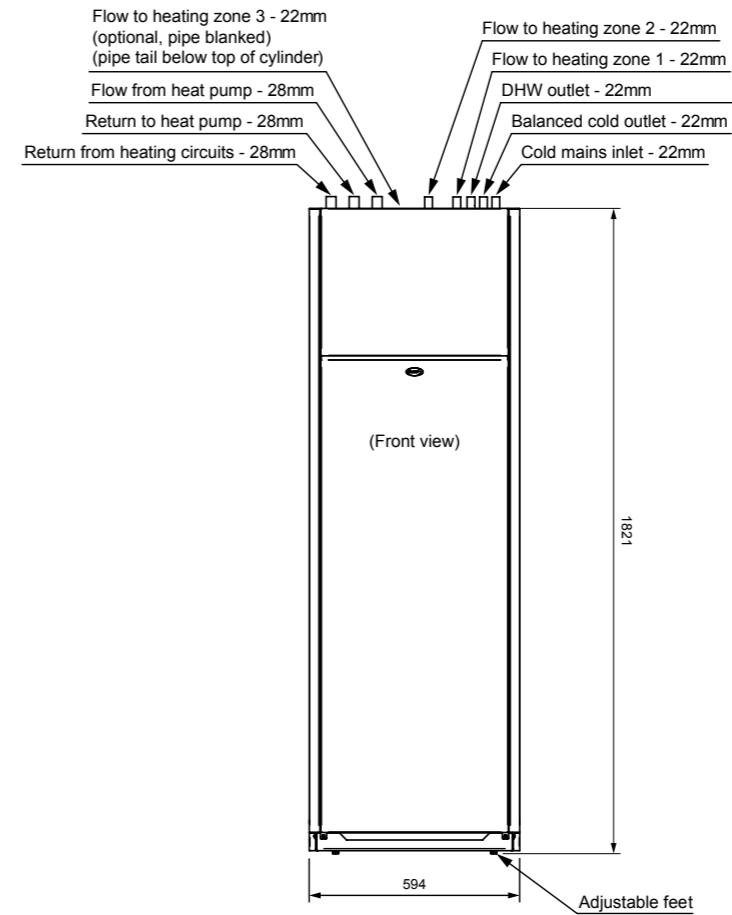
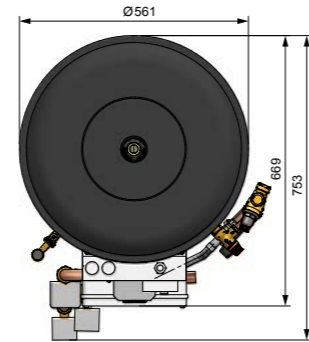

Front View

Side View

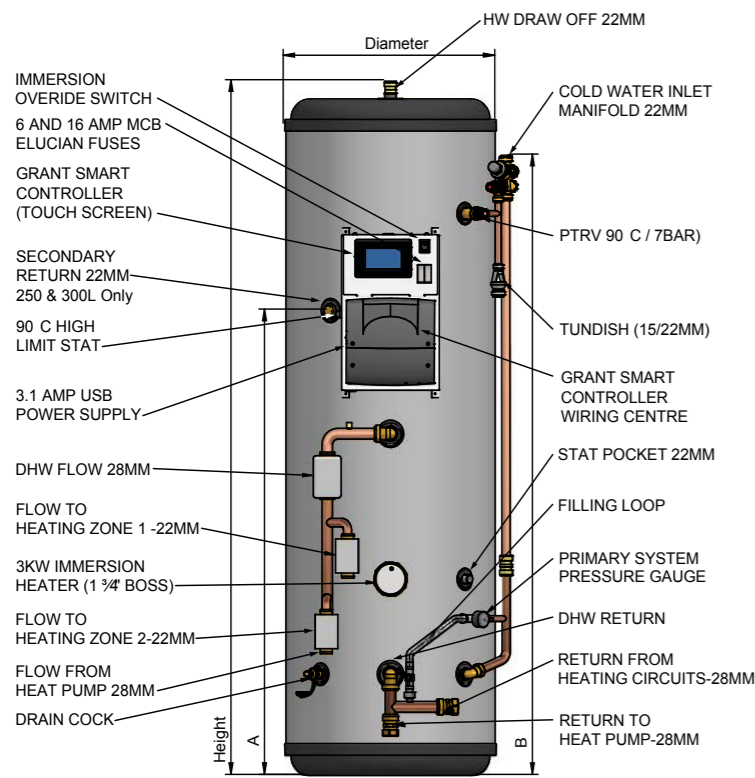

## Single Coil | Smart Pre-Plumbed

Dimensions (mm)	180L	210L	250L	300L
A*	-	-	1200	1511
B	1159	1354	1601	1940
Height	1354	1541	1792	2103
Diameter	561	561	561	561

\*Secondary return on 250 and 300 litre models only

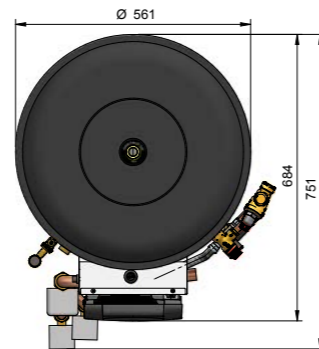

## Single Coil | Integrated

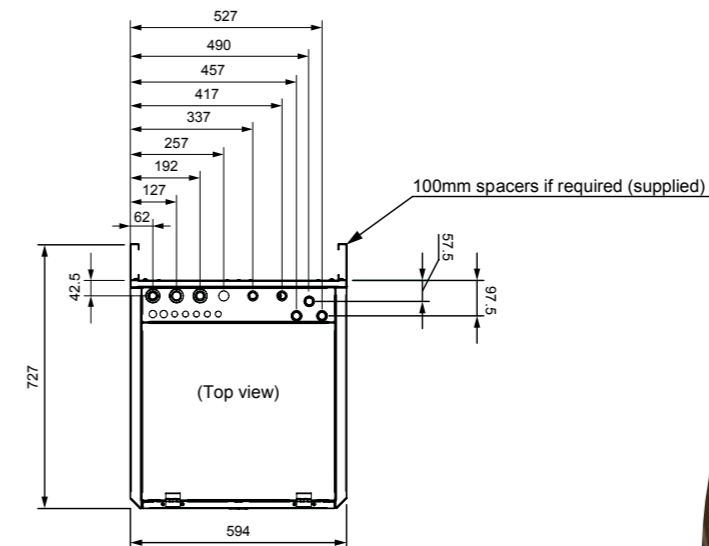

Top View





## UFLEX UNDERFLOOR HEATING RANGE

Grant's underfloor heating range consists of two systems – Uflex and Uflex MINI – both of which can be successfully used with a variety of heat sources, from traditional boilers through to renewable heating products such as air source heat pumps. When correctly designed and installed, underfloor heating will allow the heat source to work at its optimal efficiency. Homeowners can therefore not only benefit from the flexibility that this unobtrusive heat emitter offers, but they can also enjoy lower energy bills as a result of improving the overall efficiency of their heating system.

Screeded and non-screeded underfloor heating systems are available. The screeded systems use either a traditional screed, laid to 75mm thickness, or a self-levelling compound which is only poured to a depth of between 15mm-20mm. Meanwhile, the dry, non-screeded solutions use either aluminium heat emission plates or high density polystyrene boards into which the pipework is positioned and then, in most instances, the finished floor covering can be fitted directly on top. (Depending on the final floor finish, 6mm ply may need to be fitted prior to the final floor covering).

## UNDERFLOOR HEATING BY GRANT

### Highly efficient

The warm water used in underfloor heating systems has a much lower flow temperature, compared to conventional radiator systems, as it feeds into a much larger surface area. This enables it to heat a room very effectively and efficiently.

Grant's underfloor systems operate at their most efficient when they are not frequently switched off and on. The floor screed takes time to heat up, but once up to temperature it only requires a small amount of energy to maintain this. Switching the system off and on, as is commonly the case with a radiator system, results in the floor losing temperature, requiring more heat input to reach that temperature when switched back on again, and so on.

Operating systems with a 'setback' (unoccupied) control, maintains the floor at a minimum temperature during these times and avoids the wasteful use of energy to reheat the floor from cold. With this type of control the normal room temperature can be achieved during periods of occupancy, but during other periods the 'setback' control automatically drops the room temperature to a lower level. This keeps the floor warm and reduces the heat-up time when the control switches back to provide normal room temperature again.

Over time, 'setback' control will reduce the overall demand on the heat source, increasing system efficiency and lowering running costs.

### Optimal control and comfort

When designing an underfloor heating system, the pipework layout can be easily divided into zones. With both Uflex and Uflex MINI, rooms can either be split into more than one zone or multiple rooms can be incorporated into one zone. This allows homeowners to precisely control the temperature in a particular room or a space within a room. The temperature delivered is also evenly distributed from one side of the room to the other. The pipework is positioned so that the entire room will receive heat with no 'hot spots' or cool draughts. Underfloor systems radiate heat uniformly upwards, achieving a constant temperature throughout the space to deliver ultimate comfort.

### Quick & easy installation

Grant underfloor heating is supplied as packs specifically suited to meet the requirements detailed in the system designs. From the pipework and connections through to the edging strip and controls, Grant can supply all the components required. Straightforward to install and with the Uflex MINI system suitable to be fitted by a single engineer, Grant's underfloor range is user-friendly to work with and simple to maintain. Furthermore, Grant can be on hand with a full design service, providing installers with assistance from start to finish.

### Dedicated design team

Grant has a Design Team who are on hand to provide product and design assistance. This Team has extensive experience in a range of products including air source heat pumps, complementary technologies, and heat emitters such as underfloor. From product specification through to producing full designs, Grant can help installers develop bespoke package solutions to suit the heating needs of their customers.

### Quick quote turnaround

Specifying the required parts to complete an underfloor heating installation can be time-consuming so Grant are able to provide installers with comprehensive quotations, quickly and efficiently. Each quotation will detail the components required to complete the specific job being quoted for. These components can then be supplied as a pack once the order is finalised.

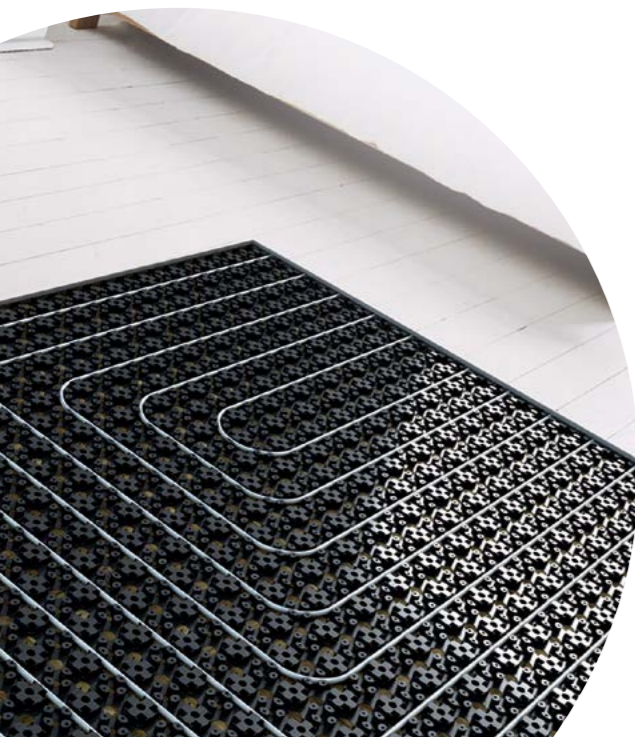

## SUITABLE FLOOR COVERINGS

When using underfloor heating it's important to consider the correct type of floor covering as not all types of finishes are suitable for use with this heat emitter. The objective of underfloor heating is to transfer heat from the system into the room and some floor coverings can restrict this movement of heat. Flooring materials such as tiles and some types of vinyl flooring are low resistance and are therefore ideal for underfloor. Meanwhile, thicker finishes such as certain types of wood and thin carpets have medium resistance which means that some of the heat is retained. Any carpets and underlay which have a combined tog of over 1.5 are not suitable for an underfloor heating system.

Tile, stone & polished screed	Vinyl flooring	Engineered timber & laminate flooring	Solid hard & soft wood	Carpet
✓ excellent heat transfer	✓ good heat transfer	✓ average heat transfer	✓ average heat transfer	✗ low heat transfer
✓ ideal for use with underfloor	✓ robust & hard wearing	✓ performs well with changes in temperature	✗ changes in temperature can cause	✗ carpet tog & underlay must not exceed 1.5
✓ can be heated to up to 29°C	✓ can be heated to up to 27°C	✓ can be heated to up to 27°C	✗ care should be taken when specifying board width & thickness	
	✗ not recommended for high heat loss areas			
Low resistance 0.01 - 0.05m <sup>2</sup> K/W		Medium resistance 0.05 - 0.1m <sup>2</sup> K/W		High resistance 0.1 - 0.15m <sup>2</sup> K/W

**IMPORTANT:** Always check with the flooring manufacturer to confirm compatibility. Check moisture content of any wood flooring and ensure real wood floor boards have acclimatised in the laying area for a minimum of one day prior to fitting.

# UFLEX

Grant's Uflex underfloor heating system is embedded into the floor construction. It is ideally suited for new builds whereby the pipework is installed during the initial stages of the property's development. The Uflex pipework is then positioned and clipped into place once the flooring's insulation and membrane has been fitted, after which a sand/cement or flow screed is laid over the top and allowed to fully dry before heat is introduced.



PEX-AL-PEX PIPE

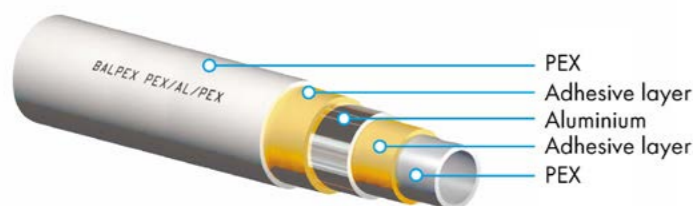

\*subject to full T&C's

With a drying time of up to thirty days, the Uflex underfloor system can be fitted as part of the floor construction process, therefore causing no delays in construction. Grant's Uflex system makes underfloor heating a viable option for a wide range of projects, from one-off new build projects and room extensions through to larger multi-property developments.

### Types of Pipe

Two types of pipe are available for installation as part of a Uflex underfloor heating system – PE-RT and PEX-AL-PEX. Both the PE-RT and PEX-AL-PEX pipe are 16mm in diameter and they are compatible with all of the Uflex system components. The two types of pipe are both flexible and easy to work with but the PEX-AL-PEX pipe, which retains its curved shape when bent into position, offers the additional benefit of being suitable for other general plumbing uses. Installers can therefore use the amount of PEX-AL-PEX pipe they need for the Uflex installation and then use the pipe elsewhere in the property's plumbing system, reducing wastage.

### Features

- Multiple installation options
- Unique edge insulation
- Simple installation

# UFLEX INSTALLATION OPTIONS

Grant's Uflex underfloor heating system can be installed using four different methods.

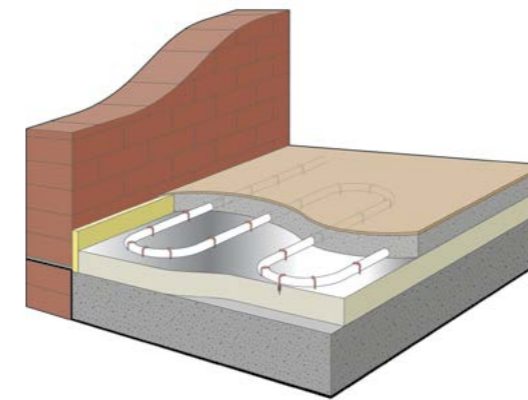

### Clips (screeded system)

When positioning the underfloor heating pipe onto floor grade insulation, U-Clips can staple the pipework into place. These can be positioned along the straight runs of pipe and where the bends are formed. The U-Clips should be positioned at 500mm intervals and a minimum of 35mm depth of insulation is required. To assist with accurately fixing the U-Clips, it is recommended that a tacker clip stapler is used.

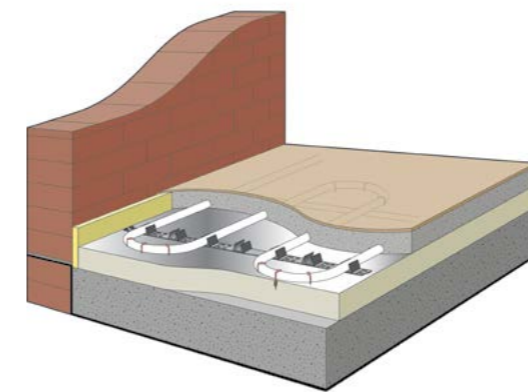

### Rails (screeded system)

Clip Rails can be used to make the laying of the Uflex pipe easier and quicker. With a self-adhesive backing, the rails are applied onto the insulation and the Uflex pipe is then clipped into the rails. U-Clips can also be used if desired to fasten the pipework on the bends. The rails can be laid across the floor in a matrix pattern (for meander pattern pipe installations) or a cross/star pattern (for bifilar pattern pipe installations). Ideal for long runs of pipework, Clip Rails keep the pipework parallel and ensure consistent spacing.

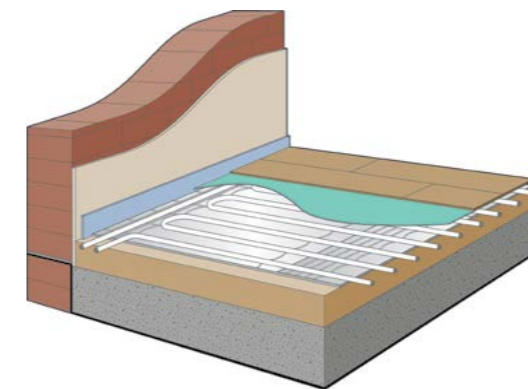

### Overlay Boards (dry system)

Grant's Overlay System, suitable for installation with both the Uflex and Uflex MINI systems, is a dry solution to installing underfloor heating and is an ideal alternative to traditional wet screeded systems. The Uflex Overlay System features 20mm thick foiled boards available with 150mm and 200mm pipe centres suitable for the Uflex & Uflex MINI pipes. Featuring pre-formed grooves for the pipework and with no need to wait weeks for a wet screed to dry, the Overlay System is quick and straightforward to install. Read more on page 37.

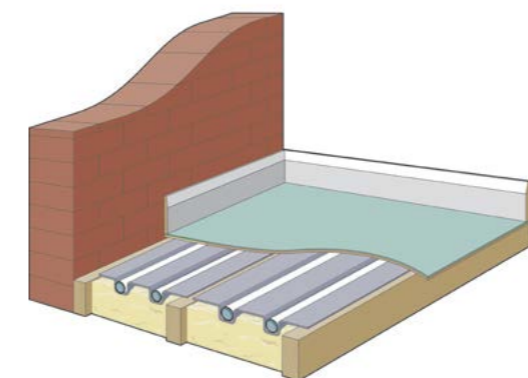

### Heat Emission Plates (dry system)

When installing the Uflex system on timber suspended or battened floors with joints or supports, heat emission plates can be used. Each plate has two pipe tracks with 200mm pipe centres. Supplied in packs of 28 plates, these plates enable heat distribution. The plates are designed to be fitted directly on top of the insulation, usually 100mm of mineral wool, which is positioned above the joists.

## UFLEX MINI

The Uflex MINI system differs to Uflex in that it can be installed over any existing sound and level floor surface and is compatible with most types of floor covering. While it is suitable for new builds, Uflex MINI is specifically designed to suit retrofits and renovations, when an underfloor heating system is to be fitted in a property with a floor construction already in place. At just 15mm finished floor height, this underfloor system can be installed incredibly quickly and with minimal disruption to a property's existing floor and door arrangements.



\*Subject to full T&C's

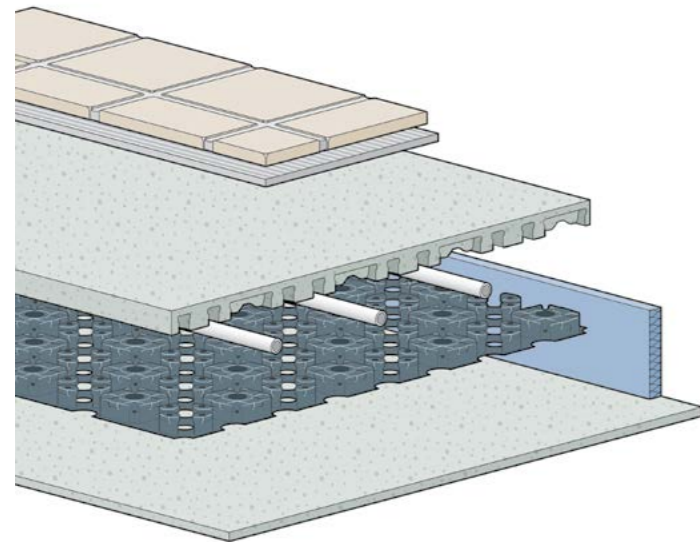

Grant's Uflex MINI underfloor heating system consists of self-adhesive panels which are simply placed on top of the sealed floor. The pipework is then clipped into place without the need for staples before a self-levelling screed is laid over the top. The flexible, self-levelling screed used with the Uflex MINI system can be walked on the following day and dries within just three days enabling the heat source to be connected shortly after, restoring heat to a property within a minimal amount of time. With so many installation-friendly features, the Uflex MINI underfloor system can deliver ultimate comfort with minimal hassle.

### Features

-  Only 15mm finished floor height
-  Fully dry in just 3 days
-  Quick reaction time
-  Simple installation
-  No overboarding required
-  Suitable for ground floor and first floor installations

## OVERLAY BOARD SYSTEM

The Grant Uflex and Uflex MINI Overlay System is an effective alternative to traditional wet screeded underfloor heating installations.

Comprising of lightweight, robust flame retardant high-density polystyrene boards, the Uflex and Uflex MINI Overlay System is a dry system which makes installing underfloor heating very straightforward. The boards can be installed on an existing wooden or concrete floor surface, providing it is dry, flat, level and structurally stable, and is ideally suited to retrofit installation scenarios. With no need to pour a wet screed, the system is considerably quicker to install compared to traditional screeded systems.

### Features

- Foiled, lightweight boards
- 16mm or 20mm thick
- Flame-retardant, high-density polystyrene with a reinforced cementitious layer on top and bottom surfaces
- Excellent impact and compressive strength



### Foiled Overlay Boards

Designed for use with wood laminate, wood panelling etc. Features a bonded layer of reflective 75micron Aluminium foil on the upper surface to enhance the rapid transmission of heat across the floor.



### Installation Sequence

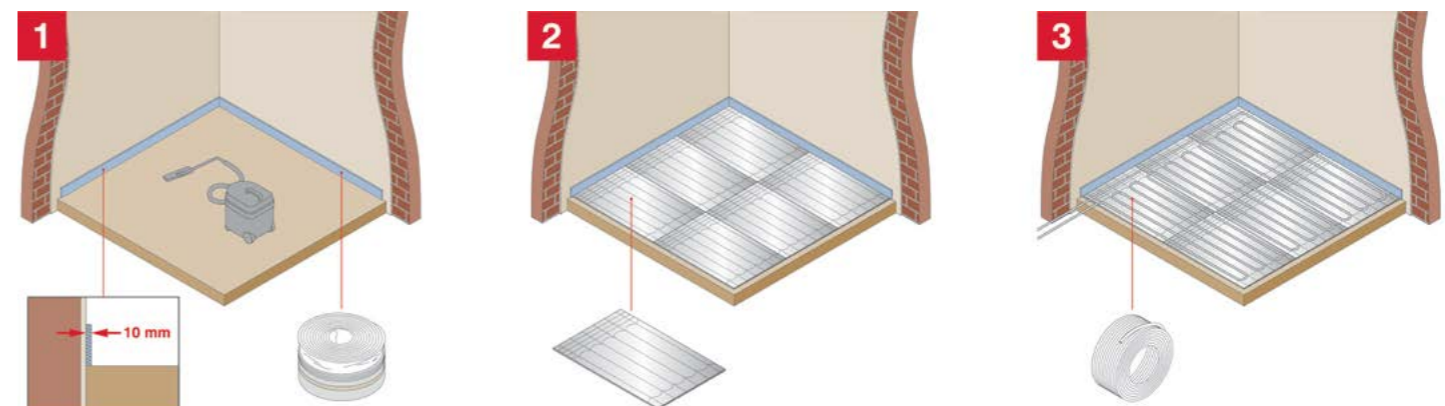

# CONTROLS

## Uflex Neostat V2

The Grant Uflex Neostat V2 is a hard-wired programmable room thermostat, operating as both a programmer and a room thermostat. The control allows homeowners to set when their heating will come on and off as well as sensing the air temperature so that when this falls below the thermostat setting, it will switch the heating on and, once the set temperature has been reached, it will switch the heating off again. Suitable for single and multi-zone installations, the Uflex Neostat V2 makes programming simple and straightforward.

## Uflex Edge

Similar to the Uflex Neostat V2, the Uflex Edge is also a hard-wired programmable room thermostat but it incorporates its own RF connection functionality to enable wireless connectivity with air temperature sensors. The Uflex Edge is designed to be paired with wireless air sensors located in different rooms or spaces within the home to provide greater temperature accuracy. When using multiple sensors, the thermostat can calculate the average temperature to effortlessly maintain desired room temperatures throughout the home and is ideally suited to larger open plan properties.

The Uflex Edge can also be paired to wireless window/door switches so that when a window or door is open, the heating is automatically switched to Standby Mode and when the window or door is closed, the unit will return the system to normal mode.

## Uflex NeoAir V3

The NeoAir V3 is a wireless programmable room thermostat which is also compatible with both the Uflex and Uflex MINI underfloor heating systems. Battery powered, the NeoAir V3 has wireless RF connectivity and it can either be used as a thermostat, a time clock or as both a thermostat and hot water timer. One remote sensor can be connected to the NeoAir V3 which can either be used to monitor the floor temperature or to provide remote air temperature sensing. When paired to the NeoHub and NeoApp, the NeoAir V3 is compatible for use with single or multiple wireless air sensors making this wireless control ideally suited to large, open plan spaces when an average air temperature needs to be calculated.

## User friendly

The Uflex Neostat V2, Uflex Edge and NeoAir V3 each have a visual display that provides homeowners with

the essential information they need to know about their system. Both the Uflex Neostat V2 and NeoAir V3 are easy to navigate with all of the programming options available across the bottom of the back lit display and the Uflex Edge has an LCD display screen with the navigating buttons located to the side of the screen. Each of these programmable thermostats allow end-users to adjust their settings, view their room-by-room temperatures and to access troubleshooting assistance when required.

The NeoApp is a supporting app that homeowners can use alongside the Uflex Neostat V2 and NeoAir V3 programmable thermostats. When the Uflex Neostat V2 and NeoAir V3 are paired to the NeoHub via a WiFi connection, this will enable remote control of the device from anywhere via the NeoHub app. Meanwhile, the Uflex Edge offers Modbus Connectivity which allows third party integrators the option to integrate the thermostat with home automation and building management systems.

All of the thermostats are slim and stylish with a glacier white finish, compact design, and their displays use a white back light which turns off automatically when not in use. Flexible programming is available with the Uflex Neostat V2, Uflex Edge and NeoAir V3 each offering 5/2 Day programming, 7 Day programming and 24 hour programming as well as a holiday function. Each device also has a key locking function, which can help reduce tampering of the heating system.

## Self Learning Preheat functionality

Each thermostat can cleverly calculate the amount of time it takes for a home to warm up to the desired temperature. Using this Self Learning Preheat calculation, the Uflex Neostat V2, Uflex Edge and NeoAir V3 can ensure a property is warm when the homeowners wake up and return home, automatically optimising this throughout the year and detecting any changes in the home that may cause the preheat time to change, helping maintain maximum system efficiency and reducing energy bills.

## Simple installation

Installing these underfloor controls is straightforward. With minimal wiring and an easy set-up process, the controls can be installed quickly and with ease with the wireless NeoAir V3 providing even greater flexibility for installation. Suitable for new installations and compatible with existing installations, the minimal commissioning saves additional time on site.

# CONTROLS

All Uflex controls are compatible with the Uflex and Uflex MINI systems and are compatible with air source heat pumps, solar thermal systems and most boiler technologies.

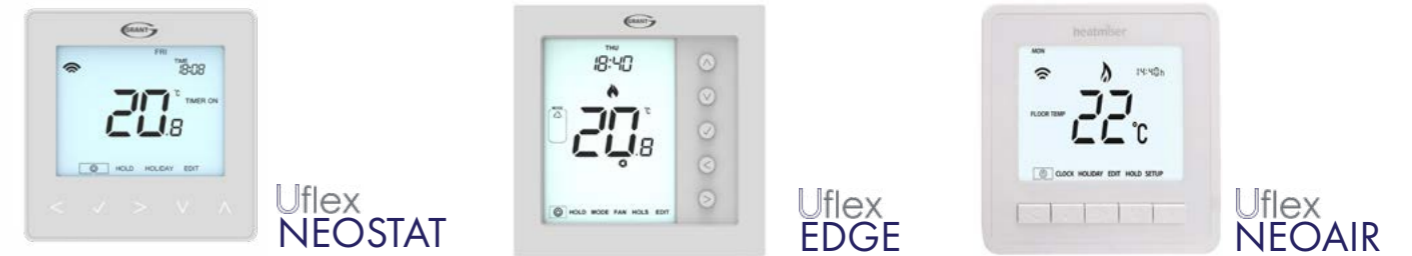

Uflex Neostat V2 with Uflex UH8 Wiring Centre	Uflex Edge with Uflex UH8 Wiring Centre	Uflex NeoAir V3 with Uflex UH8-RF Wiring Centre
Mains powered digital programmable room thermostat with 8 zone mains powered wiring centre	Mains powered digital programmable room thermostat with 8 zone mains powered wiring centre	Battery powered, wireless programmable room thermostat with 8 zone mains powered wiring centre
Up to 4 actuators can be wired to each zone, allowing for up to 32 actuators to be connected to the wiring centre	Up to 4 actuators can be wired to each zone, allowing for up to 32 actuators to be connected to the wiring centre	Up to 4 actuators can be wired to each zone, allowing for up to 32 actuators to be connected to the wiring centre
Touch sensitive buttons with clear display interface controls up to 4 heating levels & backlight proximity sensor	Mechanical buttons with clear display interface controls up to 6 heating levels	Touch sensitive buttons with clear display interface controls up to 6 heating levels
Ideally suited for installations where a secure WiFi connection is established (WiFi is not necessary for this system unless NeoHub is used)	Ideally suited for installations which do not want to be dependent on WiFi connectivity	Ideally suited for installations where a secure WiFi connection is established (WiFi is not necessary for this system unless NeoHub is used)
Can be controlled via mobile devices with the NeoHub app when paired to the NeoHub (using the home's internet router)	Not compatible with NeoHub or NeoHub app but incorporates own RF connection for connection with wireless sensors	Can be controlled via mobile devices with the NeoHub app when paired to the NeoHub (using the home's internet router)
When connected to the NeoHub, third party integration can be enabled (for example with GoogleHome and Alexa)	Integrates with Modbus Connectivity for connection to building management systems	When connected to the NeoHub, third party integration can be enabled (for example with GoogleHome and Alexa)
Programmable room thermostat with built in air sensor	Programmable room thermostat with built in air sensor and can be used as a time clock	Programmable room thermostat with additional function of a hot water timer
Remote air sensing mode is available with wireless air and door/window sensors when the Uflex Neostat V2 is connected to and controlled via NeoHub app	Remote air sensing mode is available with up to 16 wireless air and door/window sensors when paired via Uflex Edge's in-built RF connection	Remote air sensing mode is available with wireless air and door/window sensors when the Uflex NeoAir V3 is connected to and controlled via NeoHub app
Remote air/floor temperature monitoring via wired sensors or multiple air sensors*	Compatible with Wireless Air sensors*. Remote air temperature monitoring via wired air sensor also available	Can be used with either 1x remote sensor or multiple Wireless air sensors*
Remote floor temperature monitoring is available via wired floor sensor	Remote floor temperature monitoring is available via wired floor sensor	Remote floor temperature monitoring is available via wired floor sensor
230v supply required	230v supply required	230v supply required
Pump and valve exercise	Pump and valve exercise	Pump and valve exercise

\*when used with NeoHub



### Uflex NeoHub (UFLEX 70)

- The gateway to the Neo system providing remote control of all Neo thermostats from an iOS or Android device
- Connects to a home broadband router via an Ethernet cable (supplied) and wirelessly to the NeoStat and NeoAir thermostats installed in the property
- Creates a mesh network, greatly increasing the network range
- Smart Profiles: Allowing time and temperature settings to be made and then applied to a number of zones as required
- Geo-location: Automatically turns the heating off when you leave home and back on when you return
- Compatible with up to 32 Neo devices
- Compatible with Smart Home, HomeKit, Google Home, Alexa and IFTTT
- Automatic Firmware updates for NeoHub and connected devices
- Clock sync and BST correction
- Push notifications such as high/low temperature alerts, low battery warning for wireless sensors, door/window open alert (if door/window sensor is used)



### Uflex Remote Air/Floor Sensor (UFLEX 65)

- Can be used to monitor and control the floor temperature with either the Uflex Edge, NeoStat or NeoAir thermostats and is directly wired to the floor sensor terminals provided on either thermostat
- Can also be used to provide remote air temperature sensing with the Uflex NeoStat or NeoAir thermostats and is directly wired to the air sensor terminals provided on the thermostat. In this case wall-mounted Remote Sensor Enclosure (UFLEX66) can be used to conceal the temperature sensor probe
- 3 meter sensor cable which can be extended up to 20 metres using suitable 'twisted pair' shielded cable



### Uflex Remote Sensor Enclosure (UFLEX 66)

- Wall mounted enclosure used to conceal the probe of the Remote Air/Floor Sensor probe when it is used as a remote air sensor in conjunction with Uflex Neostat or Uflex NeoAir



### Uflex Thimble Sensor (UFLEX 67)

- Used to provide a discrete means of remote air temperature sensing with the Uflex NeoStat and NeoAir thermostats.
- 1.95m sensor cable which can be extended up to 20 metres using suitable 'twisted pair' shielded cable



### Uflex Wireless Air Sensor (UFLEX 68)

- Can be directly paired to the Uflex Edge thermostat via an 868MHz RF signal
- Helps calculate an average space air temperature (ideal for open plan properties)
- Can also be used instead of the internal temperature sensor of the thermostat when it is not possible to locate it in an optimal position
- A maximum of 16 wireless air sensors and window/door sensors can be connected to a single Uflex Edge thermostat
- Can be used with NeoStat/NeoAir via NeoHub and NeoApp



### Uflex Wireless Door/Window Sensor (UFLEX 69)

- Automatically switches the heating to standby when the door/window is open, automatically returning to the normal heating mode when shut
- Can be directly paired to the Uflex Edge thermostat via an 868MHz RF signal
- A maximum of 16 wireless air sensors and window/door sensors can be connected to a single Uflex Edge thermostat
- Uflex Neostat and NeoAir thermostats can be used with single or multiple wireless door/window sensors (via the NeoHub and NeoApp)
- Powered by a single LS14250 3.6V battery
- Can be fitted to a door or window frame using double-sided adhesive patches (supplied)
- Can be used with NeoStat/NeoAir via NeoHub and NeoApp

### Remote and Wireless Sensor Compatibility

	Uflex Edge	Uflex NeoStat V2	Uflex NeoAir V3
Uflex Remote Air/Floor Sensor (UFLEX65)	Yes <sup>1</sup>	Yes <sup>2</sup>	Yes <sup>3</sup>
Uflex Thimble Sensor (UFLEX67)	No	Yes	Yes
Uflex Wireless Air Sensor (UFLEX68)	Yes	Yes <sup>4</sup>	Yes <sup>4</sup>
Uflex Wireless Door/Window Sensor (UFLEX69)	Yes	Yes <sup>4</sup>	Yes <sup>4</sup>

#### Notes:

<sup>1</sup> Only one can be connected – floor temperature sensor only

<sup>2</sup> Two can be connected – either floor temperature sensor or remote air sensor (or both)

<sup>3</sup> Only one can be connected – either as floor sensor or remote air sensor (but not both)

<sup>4</sup> Only via the Neohub and NeoApp

## AFINIA ALUMINIUM RADIATORS

The Afinia Aluminium radiators combine functionality and aesthetics to deliver the ideal partner for both traditional and renewable heating systems. Available in horizontal and vertical options, the Afinia radiators are superb conductors of heat and incredibly responsive, heating up and cooling down quickly. Their curved design and sleek appearance also make them a stylish addition to any room.



## AFINIA RANGE

Grant's Afinia aluminium radiators are more efficient than traditional radiator materials, such as steel and cast iron. Aluminium has excellent thermal conductivity and this, combined with their low water content, makes these radiators incredibly effective. With low energy consumption, Afinia radiators can therefore provide cost savings for householders on their energy bills.

Being a great conductor of heat, aluminium radiators heat up and cool down very quickly, enabling them to rapidly respond to any changes in the temperature demand set via the thermostat. Afinia radiators can heat up a room in a short amount of time once set to do so by the thermostat and, equally, if the temperature setting is reduced, they will cool down quickly as well. This functionality makes the Afinia radiators incredibly adaptive heat emitters, delivering maximum room comfort.



### Compatibility & flexibility

Afinia aluminium radiators can be installed with high and low temperature heating systems which makes them compatible with all of Grant's heating products. Their performance levels, which comply with European requirements, make the Afinia range an ideal partner for renewable appliances in particular. With their smaller size, compared to steel radiators, the Afinia models work incredibly effectively with air source heat pumps.

Supplied fully assembled and available in both horizontal and vertical options, the Afinia range is adaptive to suit the location where it will be sited. The horizontal radiators are available in three heights – 430mm, 580mm and 680mm – with 6 to 15 section combinations, delivering choice and flexibility when it comes to installation. Meanwhile, the vertical models are supplied with 6 or 8 sections and are available in two heights – 1,842mm and 2,042mm – providing the perfect solution when space is limited.

### Simple installation

Afinia radiators have a number of features which make for an easy installation. They are light in weight and manageable for a single engineer to install. Each Afinia radiator comes with robust steel wall brackets which allow for the straightforward mounting of each radiator. In addition, no electricians are involved with the fitting of these aluminium radiators which allows for a quick installation, reducing installation costs.

### Aesthetics

One of the distinctive features of radiator's aesthetics is their curved, rounded surface. This design makes them stylish in appearance allowing them to subtly suit their environment. Slim in build and supplied in an off-white colour finish, Grant's Afinia radiators can suit many a home's bespoke requirements.

### Peace of mind guaranteed

All the models within the Afinia aluminium radiator range are supplied with a 15 year guarantee, reflecting their quality of build. Following extensive testing and independent verification of the radiators' efficiency, reliability and output, a market leading 15 year guarantee accompanies the Afinia aluminium radiators to provide complete peace of mind for householders.

\*Subject to full T&C's

## AFINIA RANGE TECHNICAL SPECIFICATIONS



HORIZONTAL											
Code	Panels	Output W ΔT30	Output W ΔT50	Height (mm)	Width (mm)	Section Width (mm)	Depth (mm)	Section Output W ΔT30	Section Output W ΔT50	Weight Empty (kg)	Weight Full (kg)
GALU4306KIT	6	288	552	430	480	80	95	48	92	6.06	7.56
GALU4308KIT	8	384	736	430	640	80	95	48	92	8.08	10.08
GALU43010KIT	10	480	920	430	800	80	95	48	92	10.10	12.60
GALU43012KIT	12	576	1104	430	960	80	95	48	92	12.12	15.12
GALU43014KIT	14	672	1288	430	1120	80	95	48	92	14.14	17.64
GALU5806KIT	6	366	744	580	480	80	95	61	124	8.10	10.14
GALU5808KIT	8	488	992	580	640	80	95	61	124	10.80	13.52
GALU58010KIT	10	610	1240	580	800	80	95	61	124	13.50	16.90
GALU58012KIT	12	732	1488	580	960	80	95	61	124	16.20	20.28
GALU58014KIT	14	854	1736	580	1120	80	95	61	124	18.90	23.66
GALU58015KIT	15	915	1860	580	1200	80	95	61	124	20.25	25.35
GALU6806KIT	6	432	852	680	480	80	95	72	142	9.60	11.94
GALU6808KIT	8	576	1136	680	640	80	95	72	142	12.80	15.92
GALU68010KIT	10	720	1420	680	800	80	95	72	142	16.00	19.90
GALU68012KIT	12	864	1704	680	960	80	95	72	142	19.20	23.88
GALU68014KIT	14	1008	1988	680	1120	80	95	72	142	22.40	27.86
GALU68015KIT	15	1080	2130	680	1200	80	95	72	142	24.00	29.85



VERTICAL											
Code	Panels	Output W ΔT30	Output W ΔT50	Height (mm)	Width (mm)	Section Width	Depth (mm)	Panel Output W ΔT30	Panel Output W ΔT50	Weight Empty (kg)	Weight Full (kg)
GALUV18426KIT	6	816	1626	1842	480	80	80	136	271	15.48	19.56
GALUV18428KIT	8	1088	2168	1842	640	80	80	136	271	20.64	26.08
GALUV20426KIT	6	882	1758	2042	480	80	80	147	293	16.86	21.36
GALUV20428KIT	8	1176	2344	2042	640	80	80	147	293	22.48	28.48



## GRANT SOLAR RANGE

Solar Thermal Systems from Grant allow householders to utilise the power of the sun to provide hot water to their home. An environmentally responsible alternative to traditional energy sources and fossil fuels, solar thermal technology has zero CO<sub>2</sub> emissions and efficiently uses the energy from the sun within a central heating system. Grant Solar Thermal systems are compatible with different types of roof and easily incorporate into an existing or new heating system so accessing the benefits of the inexhaustible supply of sunshine is made simple and easy.

Energy is produced from the sun throughout the year, even on cloudy days, so finding ways to transfer this energy into the home is becoming increasingly popular. Solar thermal technology can produce the energy required to heat a home's hot water almost all year round while also being an excellent way for homeowners to reduce their carbon footprint. Once installed, solar thermal is a cost effective and sustainable addition to any home's heating system.

## The basic principles

Solar thermal collectors efficiently extract the energy from the sun and transfer it into a home's hot water system. Roof-mounted solar collectors are connected to a system which contains a special glycol/water solution. While passing through the collector, this fluid is heated up and then circulated from the panel through to a cylinder where the heat is transferred to produce hot water.

## Free energy

Solar collectors do not only work in the summer, contrary to what some people may believe. The sun's free energy is available throughout the year so solar collectors also work all year round too. Collectors, such as those supplied by Grant, operate in both direct sunlight and in diffused sunlight so, even on cloudy days, they are working. During the months of May through to September in particular, solar thermal can produce 100% of the energy required to meet a home's domestic water needs.

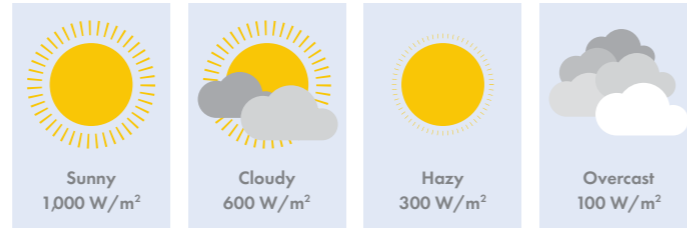

In the UK and Ireland, the amount of available solar radiation varies. The diagram here shows the total average solar radiation falling on 1m<sup>2</sup> surface, inclined at 30° to the horizontal, measured in kilowatt hours. The average property requires approximately 3,000kWh per year for domestic water heating so, as the diagram demonstrates, solar energy can provide a significant proportion of this.

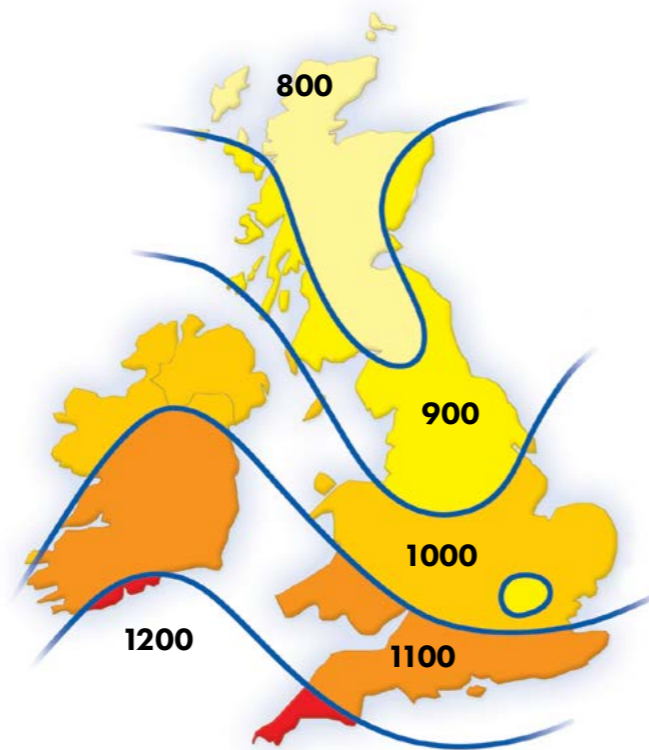

## Fit for the future

Installing solar thermal technology is beneficial in a number of ways. Not only is it a clean, sustainable method of providing homes with their hot water, a solar thermal system can also save householders up to 70% on their annual hot water heating costs. Furthermore, adding solar heating technology to a property can increase its value. Houses with solar heating are less prone to fluctuations in heating prices, making them an attractive option for potential buyers.

The Grant Solar Thermal range includes the high efficiency Sahara flat plate collector, multifunctional controller with LCD display, and various roof mounting options. In addition, the range also includes the unique Grant CombiSOL which allows solar thermal to integrate with combination boilers as well as the Grant WinterSOL which provides a fully heated cylinder of hot water during periods of low thermal gain.

## Sahara collector overview

The Grant Sahara collector has a durable extruded aluminium frame with a bronze anodised finish which has been designed to blend in with most domestic roof types. During the manufacturing process, premium materials are used to guarantee the functionality and longevity of the collectors. In addition, Grant's collectors are all tested to the requirements of BS EN 12975.

The Sahara collector has been designed to deliver maximum heat transfer. Grant use a unique patented system where the heat transfer sheet within the collector interlocks both the pipe and absorber for perfect thermal transfer. Additional aluminium plates enclose the copper pipes and this, combined with an industrial strength adhesive, result in 360° heat transfer from the absorber plate to the pipe carrying the solar fluid. Alternative systems which use a soldered absorber or an ultrasonic welded absorber provide far less contact between the pipe and heat transfer plate, making these options less efficient and more prone to water damage.

## Roof mounting options

Almost any roof type is suitable for solar thermal but, when choosing an appropriate system, there are a couple of factors worth considering. Positioning the collectors in a south facing arrangement could gain 100% of available solar energy during a day whereas a south-east or south-west facing roof will have a reduction in yield of 5-10%. Grant's Solar Thermal systems are designed to suit both sloping and flat roofs with on-roof, in-roof and flat roof mounting arrangements available.

### On-Roof

Using the on-roof mounting system, the Sahara collectors are quickly and easily located above the roof tiles or slates using brackets and a mounting rail attached directly to the roof trusses. This system is available with fixing brackets suitable for all roof tile types and on roof pitch ranges from 20° to 60°.

### In-Roof

With the in-roof mounting arrangement, the collectors are set into the roof tiles or slates ensuring a low-profile appearance. The roof surface beneath is closed within an aluminium weathering cassette incorporating flashings and drainage channels. In new build applications, this mounting option offers an additional benefit of reducing roofing costs because tiles are not required beneath the installation.

### Flat Roof

The third mounting option from Grant is the flat-roof system. This system is based upon the on-roof design with the mounting rails fitted to a rigid inclined frame structure. This method allows the collectors to be positioned quickly and easily on a flat roof or other flat surface.



# SAHARA SOLAR RANGE

Grant supply their Solar Thermal Systems as a series of individually numbered kits that meet the requirements of most installations. Each kit consists of the Sahara collector(s) (either portrait or landscape), a roof mounting system, expansion vessel, pump station, controller, pipe connections and solar fluid.

## Benefits

The Sahara solar collectors from Grant, which are Solar Keymark approved, are very effective and incredibly durable. Homeowners who choose to install Grant Solar can hope to save on their annual energy bills. Furthermore, all of Grant's solar products and components are rigorously tested to ensure the highest standards of quality and reliability are met for years to come.



\*When installed by a G1 Installer. Subject to full T&C's.



## Features

- 82.6% collector efficiency
- Significantly lower CO<sub>2</sub> emissions
- Dramatically reduced annual fuel bills
- Minimum maintenance

## Kits

### On-Roof | Portrait

- GSSKIT0 1 collector kit
- GSSKIT1 2 collector kit
- GSSKIT2 3 collector kit

### On-Roof | Landscape

- GSSKIT1LAND 2 collector kit

### In-Roof | Portrait | Tile

- GSSKIT15 1 collector kit
- GSSKIT3 2 collector kit
- GSSKIT4 3 collector kit

### In-Roof | Portrait | Slate

- GSSKIT16 1 collector kit
- GSSKIT17 2 collector kit
- GSSKIT18 3 collector kit

### In-Roof | Landscape | Tile

- GSSKIT15LAND 1 collector kit
- GSSKIT3LAND 2 collector kit
- GSS3ILT1 3 collector kit

### In-Roof | Landscape | Slate

- GSSKIT17LAND 2 collector kit

### Flat Roof | Portrait

- GSSKIT5 2 collector kit

# SOLAR THERMAL SYSTEM DESIGN

Grant Solar Thermal can easily integrate with conventional water heating systems with installation typically taking a couple of days to complete. The diagram here shows the pump station incorporated which features an air eliminator that allows the system to be both filled and purged of air in a single operation. Unlike other arrangements, there is no need to install an air vent on the roof and also no need for frequent maintenance.

## Designing a system

Grant Solar collectors have an absorber (or nett) area of 2.14m<sup>2</sup> and, as a rule of thumb, you should allow 1.0-1.3m<sup>2</sup> of nett collector area per person. For the cylinder, they require 50-60 litres capacity per m<sup>2</sup> of nett collector area. To simplify this, for a two collector system (2 x 2.14m<sup>2</sup>) you will require a cylinder of approximately 200-250 litres which would be sufficient for four people and would satisfy up to 70% of the hot water demand per annum.

When designing a solar thermal system, there are several factors that need to be considered including:

- Location & orientation of building
- Angle of inclination (roof)
- Shading of collectors
- Collector array in m<sup>2</sup>
- Hot water requirements
- Size of cylinder
- Pipe work requirements

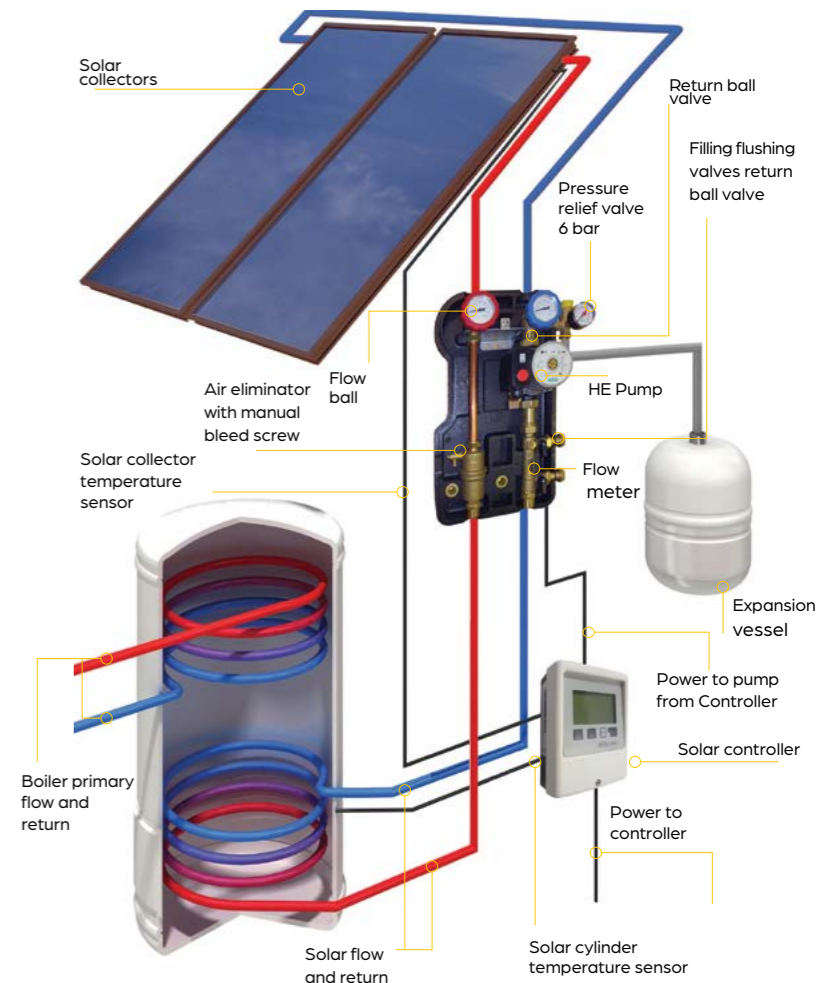

## How to calculate the number of collectors required

Direction of roof	Solar radiation kWh/Year (see map on page 50)	Number of people per household			
		<3	4	5	6
South	900 - 1000	2	2	2	3
	1000 - 1100	2	2	2	2
	1100 - 1200	2	2	2	2
South west / South east	900 - 1000	2	2	3	3
	1000 - 1100	2	2	2	3
West	1100 - 1200	2	2	2	2
	900 - 1000	2	3	3	4
	1000 - 1100	2	2	3	3
East	1100 - 1200	2	2	2	3
	900 - 1000	2	3	3	4
	1000 - 1100	2	3	3	3
	1100 - 1200	2	2	2	3



# COMPONENTS

## Solar controllers

The Grant GSX1 and GSD3X differential temperature solar controllers automatically manage the operation of the solar thermal system. Monitoring the temperature in both collector and cylinder, they operate the circulating pump only when the difference in temperature will provide efficient heating of the hot water. They will also stop the circulating pump if the temperature in the collector exceeds the maximum set or, if the cylinder has reached the required temperature.

The GSX1 controller is used for simple systems, where collectors are located on the same side of a roof – such as with a south facing installation – whereas the GSD3X is utilised for more complex projects where collectors are facing the different directions, located on either the side of a roof – such as with an East/West facing installation.

Both solar controllers monitor and display the amount of solar power produced by the system on a daily and cumulative basis. The controllers can display the collector and cylinder temperatures and also incorporate a pump kick facility which activates the pump for a short period each day to prevent the possibility of seizure if not operated for more than 24 hours.

## Expansion vessel

Available in 18 and 25 litres, the expansion vessel connects to the solar pump station by a flexible hose. It incorporates a special membrane selected to withstand the higher temperatures found in solar thermal systems.



## Solar pump station

The Grant Solar pump station has been designed to be compact. The unit has a black insulating cover, housing the high efficiency circulating pump, along with all other control components and is designed for vertical wall mounting.

The flow and return ball valves incorporate temperature gauges to monitor the return and flow temperatures and have integral antigravity brakes to prevent gravity circulation around the circuit when the pump is stopped. The air separator has a manual bleed screw and allows for rapid air removal from the sealed system. The 6 bar pressure relief valve is mounted on a manifold with the system pressure gauge and expansion vessel connection.

Filling and flushing of the system is made easy by the combined fill and flush valve assembly and the adjustment of fluid flow rate is simple using the integral flow indicator.

## Solar fluid

The solar fluid is an odour-free, non-toxic 40/60 propylene glycol/water solution, developed specifically for solar thermal applications to protect systems from freezing. The nitrate, phosphate and ammonia free fluid has been formulated to remain stable over long periods of time and is also a good corrosion inhibitor. It is available ready mixed in 10 or 20 litre packs.



# COMBISOL & WINTERSOL

## Grant CombiSOL

Solar thermal systems are increasing in popularity in the UK and many new and existing heating installations involve mains pressure combination boilers. A simple, cost effective solution to integrate these two technologies is therefore needed and this is precisely what the Grant CombiSOL does. It is uniquely compatible with most combi boilers and fuel types, cleverly combining the two energy sources.

The Grant CombiSOL works by accurately controlling the outlet temperature of stored secondary hot water produced by the solar thermal system. If the stored water is hot enough it directs the flow straight to the hot water outlet without passing through the combi boiler but if the water is colder it directs it via the combi boiler to the same outlet with a seamless changeover. There are additional minimal temperature fluctuations at the taps and Grant has refined the use of each valve (marked clearly on the white cap) to give optimum control of hot water delivery to the taps.

The unit also accurately regulates the inlet water temperature to the combination boiler, therefore installing the Grant CombiSOL with any combi boiler should not pose a problem, as the mixed water into the appliance is limited to a maximum of 28°C.

## Technical Information

The unique thermostatic change-over valves provide a safe and simple solution for adding renewable energies to the home without having the added expense of changing the central heating appliance. However, it is important to ensure that the combination boiler can accept an incoming cold mains water temperature of up to 28°C and Grant recommends that the boiler manufacturer is contacted to verify this.

## Grant WinterSOL

When there are times of low solar gain, the Grant WinterSOL provides a fully heated cylinder to ensure that the household's hot water demand is satisfied. During the winter months, there may not be sufficient solar (or heat pump) gain so the Grant WinterSOL has been designed to provide back-up for heating the water within the cylinder.

For example, 150 litres of hot water from a 300 litre cylinder may be insufficient. By fitting the Grant WinterSOL, a simple summer/winter switch can be operated by the homeowner, allowing the central heating boiler to heat the full contents of the cylinder. When solar gain is restored, the switch is set back to summer mode for maximum efficiency. This unit does not directly prevent solar thermal or heat pump systems from operating as it is only energised during the normal programmed hot water period.



## GUARANTEES

Grant's products have been designed and built to last for years. Installers and homeowners who choose the Grant brand can be assured by the reliability, quality and value of each product. To reflect the confidence that the Company has in all of their appliances, standard and extended guarantees are available throughout the ranges.

### Quality guaranteed as standard

Grant UK guarantees the manufacture of their products for a period of twelve months from the date of installation as standard, provided that the product has been installed in full accordance with the installation and servicing manual supplied. This guarantee will be extended to a total period of two years if the product is registered with Grant UK within thirty days of installation and serviced at twelve monthly intervals. Please be advised that in cases when the installation is completed more than six months from the date of purchase, the guarantee period will commence six months from the date of purchase.

Each Grant product is supplied with a copy of the standard guarantee Terms and Conditions within the supporting Installation and User Instruction documents. Grant UK strongly recommends that customers thoroughly read these Terms and Conditions to ensure that they comply and adhere to them in order to maintain their product's standard guarantee.

### Extended guarantees through the G1 Installer Network

The standard two year guarantee on Grant's renewable product ranges can be increased if the unit is installed by one of Grant UK's G1 Installers. G1 Installers can offer extended guarantees on the Grant products that they purchase, install and register. The G1 extended product guarantees are subject to the product being installed in full accordance with both the installation and servicing instructions as well as the G1 Scheme Terms and Conditions. Please note, G1 extended guarantees are only activated when the G1 Installer registers the appliance via their G1 Portal or Click App.



Grant UK's G1 Scheme provides installers with the essential tools that they need to successfully fit and endorse Grant products, which in turn gives members confidence in the products they install. Homeowners who choose a G1 engineer can be confident that their Grant product is installed to the highest possible standards while also enjoying the peace of mind that comes with the extended guarantees that G1 installers can activate on their installations.

Homeowners looking to find a G1 Installer in their local area should visit Grant UK's website and use the Find an Engineer online search: [www.grantuk.com/support/find-an-installer](http://www.grantuk.com/support/find-an-installer).









### Extended Warranty Packages

When a Grant product is not installed by a G1 Installer, homeowners can still increase the warranty on their appliance. Grant UK offer a range of three year extended warranty options which are exclusively available for products (including heat pumps and cylinders) registered within thirty days of installation. These are designed to give homeowners added peace of mind after the standard two year product guarantee has expired.

To read more about the extended product warranties available to purchase from Grant UK, please visit: [www.grantuk.com/support/extended-warranties](http://www.grantuk.com/support/extended-warranties).

## GUARANTEES

Provided below is a summary of the standard and G1 extended guarantees which are available from Grant UK on their renewable product ranges.

		 STANDARD	 G1
	Aerona Heat Pumps	2 years	7 years*
	VortexAir Hybrid	2 years	5 years*
	EvoLink Smart Hybrid Hub	2 years	2 years
	Solar Thermal Collector	5 years	10 years
	Solar Thermal Kit	5 years	5 years
	Cylinders Body	25 years	25 years
	Cylinders Components	2 years	5 years
	Uflex Underfloor Heating Pipe	25 years	25 years
	Uflex Underfloor Heating Mechanical & Electrical components	2 years	2 years
	Afinia Radiators	15 years**	15 years**

All guarantees are subject to Terms & Conditions

\*Product must be fitted with Grant Mag One DUO magnetic filter

\*\* Parts only guarantee

# PRODUCT LIST

AIR SOURCE HEAT PUMPS			
HPID6R32BODY	Aerona <sup>3</sup> 6kW R32 Air Source Heat Pump		
HPID10R32BODY	Aerona <sup>3</sup> 10kW R32 Air Source Heat Pump		
HPID13R32BODY	Aerona <sup>3</sup> 13kW R32 Air Source Heat Pump		
HPID17R32BODY	Aerona <sup>3</sup> 17kW R32 Air Source Heat Pump		
HPR2904	Aerona 290 4kW Air Source Heat Pump		
HPR29065	Aerona 290 6.5kW Air Source Heat Pump		
HPR2909	Aerona 290 9kW Air Source Heat Pump		
HPR29012	Aerona 290 12kW Air Source Heat Pump		
HPR290155	Aerona 290 15.5kW Air Source Heat Pump		
HEAT PUMP CONTROLLERS & CONTROLLER ACCESSORIES			
		AERONA <sup>3</sup>	AERONA 290
HPIDR32CON6	Aerona <sup>3</sup> R32 Remote Controller Kit (HPID6R32)	✓	✗
HPIDR32CON10	Aerona <sup>3</sup> R32 Remote Controller Kit (HPID10R32)	✓	✗
HPIDR32CON1317	Aerona <sup>3</sup> R32 Remote Controller Kit (HPID13R32 & HPID17R32)	✓	✗
HPIDR32SMART6	Aerona <sup>3</sup> R32 Smart Controller Kit (HPID6R32)	✓	✗
HPIDR32SMART10	Aerona <sup>3</sup> R32 Smart Controller Kit (HPID10R32)	✓	✗
HPIDR32SMART1317	Aerona <sup>3</sup> R32 Smart Controller Kit (HPID13R32 & HPID17R32)	✓	✗
HP32SMART6PP	Aerona <sup>3</sup> R32 Smart Controller Kit for Pre Plumbed Cylinder (HPID6R32)	✓	✗
HP32SMART10PP	Aerona <sup>3</sup> R32 Smart Controller Kit for Pre Plumbed Cylinder (HPID10R32)	✓	✗
HP32SMART1317PP	Aerona <sup>3</sup> R32 Smart Controller Kit for Pre Plumbed Cylinder (HPID13R32 & HPID17R32)	✓	✗
HPIDSMARTCONKIT	Aerona <sup>3</sup> Smart Controller - Wiring Centre - Sensors - Hub	✓	✗
HP290SMART	Aerona 290 Smart Controller Kit	✗	✓
HP290SMARTPP	Aerona 290 Smart Controller Kit for Pre Plumbed Cylinders	✗	✓
HPIDSMARTRECEIVER	Aerona Smart Wireless Receiver	✓	✓
HPIDSMARTWRT	Aerona Smart Wireless Thermostat (no receiver)	✓	✓
HPIDSMARTWRTR	Aerona Smart Wireless Thermostat (with receiver)	✓	✓
HPIDSMARTHRT	Aerona Smart Wired Thermostat	✓	✓
HPIDSMARTSEN2	Aerona Smart Water Temperature Sensor 2m	✓	✓
HPIDSMARTSEN4	Aerona Smart Water Temperature Sensor 4m	✓	✓
HPIDSMARTWSEN	Aerona Smart Outdoor Air Temperature Sensor	✓	✓
HPIDSMARTHUB	Aerona Smart Controller Wi-Fi Hub (In the con kit)	✓	✓
HPIDSMARTFLO	Aerona <sup>3</sup> Smart Flow Sensor	✓	✗
HPIDSMARTIMM	Aerona Smart Immersion Relay	✓	✓
HEAT PUMP ACCESSORIES			
HPIDSYLLHKIT	System combined volumiser/low loss header (70kW) Kit c/w 2x 28mm valves	✓	✓
HPAWSSK12	12 Litre sealed system kit	✓	✓
HPAWSSK18	18 Litre sealed system kit	✓	✓
HPAWSSK50	50 Litre sealed system kit	✓	✓
HPID120	28mm 3-Port diverter valve	✓	✓
HPID122	22mm 3-Port mixing valve	✓	✓
HPID123	230 VAC Floating Actuator (22mm 3-Port mixing valve)	✓	✓
HPIDFOOT/KIT2	Flexi-foot kit with fixings (2 x 600mm)	✓	✓
HPIDINSU/KIT	Through wall insulation kit to fit 22-28mm flexi hose	✓	✓
EML/100A	Wall mounted electricity meter	✓	✓
HPIDHEATMETER2	Heat meter kit (compatible with HPID6R32, HPID10R32, HPR2904, HPR29065, HPR29012)	✓	✓
HPIDHEATMETER	Heat meter kit (compatible with HPID13R32, HPID17R32, HPR290155)	✓	✓
HPIDAC32	AC isolator 32amp	✓	✓
VM01DUO	Mag One DUO 22mm - 28mm central heating magnetic filter	✓	✓
VM04DUO	Mag One DUO fill and flush connection kit	✓	✓
HPIDWALLBRKT3	Heat pump wall bracket (Type 2 up to 250kg) BLACK	✓	✓

# PRODUCT LIST

HEAT PUMP ACCESSORIES			
		AERONA <sup>3</sup>	AERONA 290
HPIDVOL30EXT	30 Litre external volumiser c/w 3kW backup heater (for HPID10R32, HPID13R32, HPID17R32)	✓	✗
HPIDVOL30EXT6	30 Litre external volumiser c/w 3kW backup heater (for HPID6R32)	✓	✗
HPWPR1	Hot Water Priority Relay	✓	✗
HPWPR2	Hot Water Priority Relay (2 CH Zone)	✓	✗
HPIDTM4	DHW Programmer	✓	✗
EP001	Wiring centre	✓	✗
HPIDT205	7 Day immersion programmer	✓	✗
EP002	Heat Pump wiring interface	✓	✗
INHIB03	Inhibitor/ anti-freeze 25 litre	✓	✓
HPIDWALLBRKT2	Aerona <sup>2</sup> heat pump wall bracket (M-Type up to 90kg) (for HPID6R32, HPID10R32)	✓	✗
HEAT PUMP HOSE KITS			
		AERONA <sup>3</sup>	AERONA 290
• HPHOSEKIT	Aerona 290 standard flexi hose and valve kit	✗	✓
• HPHOSEKITPRO	Aerona 290 Primary Pro insulated flexi hose and valve kit	✗	✓
HEAT PUMP INSTALLATION PACKS			
		AERONA <sup>3</sup>	AERONA 290
HPIDR32PACKA*	<b>Aerona<sup>3</sup> installation pack A - S-Plan Non Pre-plumbed with Low Loss Header</b> (Components: combined volumiser/low loss header, isolation valves, 7 day Immersion Programmer (legionella), flexi foot kit, Mag One DUO filter, 18L sealed system kit, wiring centre c/w DHW priority, DHW programmer, 32A AC isolator)	✓	✗
HPIDR32PACKK*	<b>Aerona<sup>3</sup> installation pack K - S-Plan Non Pre-plumbed</b> (Components: 7 day Immersion Programmer (legionella), flexi foot kit, Mag One DUO filter, 18L sealed system kit, wiring centre c/w DHW priority, DHW programmer, 32A AC isolator)	✓	✗
HPIDR32PACKB*	<b>Aerona<sup>3</sup> installation pack B - S-Plan for Grant Pre-plumbed cylinders with Low Loss Header</b> (Components: combined volumiser/low loss header, isolation valves, flexi foot kit, Mag One DUO filter, 18L sealed system kit, DHW programmer, 32A AC isolator)	✓	✗
HPIDR32PACKL*	<b>Aerona<sup>3</sup> installation pack L - S-Plan for Grant Pre-plumbed cylinders</b> (Components: flexi foot kit, Mag One DUO filter, 18L sealed system kit, DHW programmer, 32A AC isolator)	✓	✗
HPIDR32PACKC*	<b>Aerona<sup>3</sup> installation pack C - Direct Non Pre-plumbed with Low Loss Header</b> (Components: combined volumiser/low loss header, isolation valves, DHW Programmer, flexi foot kit, Mag One DUO filter, 18L sealed system kit, heat pump wiring interface, hot water priority relay, 28mm 3-port diverter valve, cylinder sensor, 7 day Immersion Programmer (legionella), 32A AC isolator)	✓	✗
HPIDR32PACKM*	<b>Aerona<sup>3</sup> installation pack M - Direct Non Pre-plumbed cylinders</b> (Components: DHW Programmer, flexi foot kit, Mag One DUO filter, 18L sealed system kit, heat pump wiring interface, hot water priority relay, 28mm 3-port diverter valve, cylinder sensor, 7 day Immersion Programmer (legionella), 32A AC isolator)	✓	✗
HPIDPACKP	<b>Aerona installation pack P - Direct S-Plan Non Pre-plumbed 2 Port Valve</b> (Components: flexi foot kit, Mag One DUO filter, 18L sealed system kit, 32A AC isolator)	✓	✓
HPIDPACKQ	<b>Aerona installation pack Q - Open Loop Direct Non Pre-plumbed 3 Port Diverter &amp; Mixing Valve</b> (Components: flexi foot kit, Mag One DUO filter, 18L sealed system kit, 32A AC isolator, 3-port diverter valve, 3-port mixing valve, Mixing valve actuator)	✓	✓
HPIDPACKR	<b>Aerona installation pack R - Open Loop Direct Non Pre-plumbed 3 Port Diverter Valve</b> (Components: flexi foot kit, Mag One DUO filter, 18L sealed system kit, 32A AC isolator, 3-port diverter valve)	✓	✓
HPIDPACKT	<b>Aerona Installation Pack T - S-Plan for Smart Pre-plumbed</b> (Components: flexi foot kit, Mag One DUO filter, 18L sealed system kit, 32A AC Isolator)	✗	✓

• New Product - Available from 1st February 2026  
\* FOR USE WITH REMOTE CONTROLLER ONLY

HYBRID SYSTEMS	
HPIDAIR1526	VortexAir 15/26kW Oil Boiler and 17kW Heat Pump Hybrid c/w EZ90B flue
HPIDKW/HMETER	VortexAir DIN rail mounted electricity meter
EVOLINKSMART	EvoLink Smart Hybrid System Hub

# PRODUCT LIST

QR CYLINDERS	
QR2SC150	Quick Recovery 2 Single Coil 150L cylinder
QR2SC180	Quick Recovery 2 Single Coil 180L cylinder
QR2SC210	Quick Recovery 2 Single Coil 210L cylinder
QR2SC250	Quick Recovery 2 Single Coil 250L cylinder
QR2SC300	Quick Recovery 2 Single Coil 300L cylinder
QRTC210	Quick Recovery Twin Coil 210L cylinder
QRTC250	Quick Recovery Twin Coil 250L cylinder
QRTC300	Quick Recovery Twin Coil 300L cylinder
QR2SC210PP	Quick Recovery 2 Pre-Plumbed Single Coil 210L cylinder
QR2SC250PP	Quick Recovery 2 Pre-Plumbed Single Coil 250L cylinder
QR2SC300PP	Quick Recovery 2 Pre-Plumbed Single Coil 300L cylinder
QR2SMART180PP	Quick Recovery 2 Smart Pre-Plumbed Single Coil 180L cylinder
QR2SMART210PP	Quick Recovery 2 Smart Pre-Plumbed Single Coil 210L cylinder
QR2SMART250PP	Quick Recovery 2 Smart Pre-Plumbed Single Coil 250L cylinder
QR2SMART300PP	Quick Recovery 2 Smart Pre-Plumbed Single Coil 300L cylinder
QR2SC150SL	Quick Recovery 2 Single Coil Slimline 150L cylinder
QR2SC180SL	Quick Recovery 2 Single Coil Slimline 180L cylinder
QR2SC210SL	Quick Recovery 2 Single Coil Slimline 210L cylinder
QRINTSC210	Quick Recovery Integrated Single Coil 210L Cylinder
MB-24	Quick Recovery Cylinder Plinth
MB-50	Quick Recovery Cylinder Stand
HPIDVOL50	50 Litre internal volumiser c/w immersion
HPIDVOL50X	50 Litre internal volumiser w/o immersion
HPIDVOL30EXT	30 Litre external volumiser c/w 3kW backup heater (for HPID10R32, HPID13R32, HPID17R32)
HPIDVOL30EXT6	30 Litre external volumiser c/w 3kW backup heater (for HPID6R32)

SAHARA SOLAR THERMAL	
GSSKIT0	1 collector on-roof portrait kit
GSSKIT1	2 collector on-roof portrait kit
GSSKIT2	3 collector on-roof portrait kit
GSSKIT5	2 collector flat roof portrait kit
GSSKIT15	1 collector in-roof portrait tile kit
GSSKIT16	1 collector in-roof portrait slate kit
GSSKIT3	2 collector in-roof portrait tile kit
GSSKIT17	2 collector in-roof portrait slate kit
GSSKIT4	3 collector in-roof portrait tile kit
GSSKIT18	3 collector in-roof portrait slate kit
GSSKIT1LAND	2 collector on-roof landscape kit
GSSKIT15LAND	1 collector in-roof landscape tile kit
GSSKIT3LAND	2 collector in-roof landscape tile kit
GSSKIT17LAND	2 collector in-roof landscape slate kit
GSS3ILT1	3 collector in-roof landscape tile kit
COMSOL3	CombISOL kit
WINTERSOL1	WinterSOL kit

AFINIA ALUMINIUM RADIATORS	
GALU4306KIT	Afinia 430mm 6 panel radiator, 2 X brackets & installing kit
GALU4308KIT	Afinia 430mm 8 panel radiator, 2 X brackets & installing kit
GALU43010KIT	Afinia 430mm 10 panel radiator, 2 X brackets & installing kit
GALU43012KIT	Afinia 430mm 12 panel radiator, 2 X brackets & installing kit
GALU43014KIT	Afinia 430mm 14 panel radiator, 3 X brackets & installing kit
GALU5806KIT	Afinia 580mm 6 panel radiator, 2 X brackets & installing kit
GALU5808KIT	Afinia 580mm 8 panel radiator, 2 X brackets & installing kit
GALU58010KIT	Afinia 580mm 10 panel radiator, 2 X brackets & installing kit

# PRODUCT LIST

AFINIA ALUMINIUM RADIATORS	
GALU58012KIT	Afinia 580mm 12 panel radiator, 2 X brackets & installing kit
GALU58014KIT	Afinia 580mm 14 panel radiator, 3 X brackets & installing kit
GALU58015KIT	Afinia 580mm 15 panel radiator, 3 X brackets & installing kit
GALU6806KIT	Afinia 680mm 6 panel radiator, 2 X brackets & installing kit
GALU6808KIT	Afinia 680mm 8 panel radiator, 2 X brackets & installing kit
GALU68010KIT	Afinia 680mm 10 panel radiator, 2 X brackets & installing kit
GALU68012KIT	Afinia 680mm 12 panel radiator, 2 X brackets & installing kit
GALU68014KIT	Afinia 680mm 14 panel radiator, 3 X brackets & installing kit
GALU68015KIT	Afinia 680mm 15 panel radiator, 3 X brackets & installing kit
GALUV18426KIT	Afinia 1842mm 6 panel vertical radiator, 4 X brackets & installing kit
GALUV18428KIT	Afinia 1842mm 8 panel vertical radiator, 4 X brackets & installing kit
GALUV20426KIT	Afinia 2042mm 6 panel vertical radiator, 4 X brackets & installing kit
GALUV20428KIT	Afinia 2042mm 8 panel vertical radiator, 4 X brackets & installing kit
GALUVERTBRK	Afinia Vertical Radiator Brackets (Top & Bottom)
GALUBRK430	Afinia wall bracket for 430mm section (single)
GALUBRK580	Afinia wall bracket for 580mm section (single)
GALUBRK680	Afinia wall bracket for 680mm section (single)
GALUX1KT12SM	Afinia radiator installation kit

UFLEX UNDERFLOOR HEATING					
PIPES	UFLEX00	Uflex 16mm UFH Pipe 80m	ACCESSORIES	UFLEX22	Uflex Conduit 28/23 Black 50m
	UFLEX01	Uflex 16mm UFH Pipe 120m		UFLEX23	Uflex Multi Edging Strip With Foil Pe 50m 150x10mm
	UFLEX02	Uflex 16mm UFH Pipe 240m		UFLEX24	Uflex Tacker Pipe Clip Long 55mm (Pack Of 300)
	UFLEX04	Uflex 16mm UFH Pipe 500m		UFLEX26	Uflex Compression Adapter 16x2,0-G3/4" Fteuro
	UFLEX106	Uflex MINI 10mm UFH pipe 120m		UFLEX27	Uflex MINI Nubfoil 8pce, 6.2m <sup>2</sup> 1100x700x12mm
	UFLEX107	Uflex MINI 10mm UFH pipe 240m		UFLEX28	Uflex MINI Edging Strip (Self Adhesive) 20m 80x8mm
	UFLEX108	Uflex MINI 10mm UFH pipe 480m		UFLEX44	Uflex Fix Clamp Track With Glue 14-20mm C/C 50mm 1m (Pack Of 100)
	UFLEX102	Uflex PEX-AL-PEX 16mm UFH Pipe 100m		UFLEX44S	Uflex Fix Clamp Track With Glue 14-20mm C/C 50mm 1m (single)
	UFLEX101	Uflex PEX-AL-Hpde 16mm UFH Pipe 200m		UFLEX50X	Uflex Compression Repair Connector (incl. fittings for 16mm pipe)
	UFLEX104	Uflex PEX-AL-PEX 16mm UFH Pipe 500m		UFLEX51	Uflex MINI Compression Repair Connector
OVERLAY BOARDS	UFLEX127	Uflex MINI overlay panel 10mm x 100mm foiled (single)	UFLEX105X	PEX-AL-PEX Eurocone Coupling Set 16mm	
	UFLEX128	Uflex overlay panel 16mm x 150mm foiled (single)	UFLEX110	Uflex Limit Thermostat For Pump/Mixer Uflex109	
	UFLEX129	Uflex overlay panel 16mm x 200mm foiled (single)	UFLEX111	Uflex Manifold Low Loss Header	
	UFLEX47	Uflex heat emission plate double 400mm (pack of 28)	UFLEX112	Uflex Connection Angle Set	
	UFLEX47S	Uflex heat emission plate double 400mm (single)	UFLEX91	Uflex Multi Bend Support 15-16	
	UFLEX75X	Uflex Manifold FM 2X3/4 EURO	UFLEX116	Uflex MINI Pipe Bend Support - 10mm UFH Pipe	
	UFLEX76X	Uflex Manifold FM 3X3/4 EURO	UFLEX115	Eurocone Coupling for Uflex MINI pipe 10X1.3	
	UFLEX77X	Uflex Manifold FM 4X3/4 EURO	UFLEX62	Uflex Neostat V2	
	UFLEX78X	Uflex Manifold FM 5X3/4 EURO	UFLEX63	Uflex Edge With Modbus	
MANIFOLDS	UFLEX79X	Uflex Manifold FM 6X3/4 EURO	UFLEX117	Uflex NeoAir V3 Wireless Programmable Thermostat	
	UFLEX80X	Uflex Manifold FM 7X3/4 EURO	UFLEX118	Uflex UH8-RF V2 Wiring Centre (for NeoAir)	
	UFLEX81X	Uflex Manifold FM 8X3/4 EURO	UFLEX64	Uflex UH8 Wiring Center (8 Zones)	
	UFLEX82X	Uflex Manifold FM 9X3/4 EURO	UFLEX65	Uflex Remote Air/Floor Sensor Underfloor	
	UFLEX83X	Uflex Manifold FM 10X3/4 EURO	UFLEX66	Uflex Sensor Enclosure	
	UFLEX84X	Uflex Manifold FM 11X3/4 EURO	UFLEX67	Uflex Thimble Sensor	
	UFLEX85X	Uflex Manifold FM 12X3/4 EURO	UFLEX68	Uflex Wireless Air Sensor	
	UFLEX109X	Uflex Mixing/ Pump Unit (incl. isolation valves 3/4 x 3/4 x 2)	UFLEX69	Uflex Wireless Door/Window Sensor	
	UFLEX92	Uflex Blanking Plugs (for manifolds) x 2	UFLEX70	Uflex NeoHub	
	UFLEX29	Uflex Multi Uncoiler Telescope	UFLEX71	Uflex 230v Actuator	
TOOLS	UFLEX30	Uflex Tacker Clip Stapler Magazine 14-20mm L=700m			
	UFLEX57	Uflex Multi Layer Tube Cutter (26mm)			



**Grant Engineering (UK) Ltd**  
sales@grantuk.com | grantuk.com | +44 (0)1380 736920