

# Grant QR2 Smart Range

## Pre-Plumbed Indirect Heat Pump Cylinder

### Installation, Servicing and Operating Instructions

For use with  
Grant  
Aerona 290  
& Grant  
Aerona<sup>3</sup>  
Heat pumps



## IMPORTANT NOTE FOR INSTALLERS

These instructions are intended to guide Installers on the installation, commissioning and servicing of a Grant Smart Quick Recovery pre-plumbed indirect heat pump cylinder. After installing the cylinder, leave these instructions with the user.

User instructions to guide users in the operation of the cylinder are in Section 12 of these instructions.

## SPECIAL TEXT FORMATS

The following special text formats are used in these instructions for the purposes listed below:

### ! WARNING !

Warning of possible human injury as a consequence of not following the instructions in the warning.

### ! CAUTION !

Caution concerning likely damage to equipment or tools as a consequence of not following the instructions in the caution.

### ! NOTE !

Used for emphasis or information not directly concerned with the surrounding text but of importance to the reader.

## PRODUCT CODES AND SERIAL NUMBERS

The serial numbers used on Grant Aerona Smart Controller consist of a ten digit numerical code.

For example:

1006986828

This serial number can be found on a label attached to the wiring centre of the Smart Controller attached to the front of the cylinder.

Grant Quick Recovery Smart Pre-Plumbed Single Coil Cylinder	Product Code
180 litre	QR2SMART180PP
210 litre	QR2SMART210PP
250 litre	QR2SMART250PP
300 litre	QR2SMART300PP

## SERVICING

The cylinder should be serviced at least every twelve months and the details entered in the Service Log in Appendix D at the back of these instructions.



## GRANT ENGINEERING (UK) LIMITED

Frankland Road, Blagrove Industrial Estate, Swindon, SN5 8YG

Tel: +44 (0)1380 736920 Fax: +44 (0)1380 736991

Email: [info@grantuk.com](mailto:info@grantuk.com) [www.grantuk.com](http://www.grantuk.com)

This manual is accurate at the date of printing but will be superseded and should be disregarded if specifications and/or appearances are changed in the interests of continued product improvement. However, no responsibility of any kind for any injury, death, loss, damage or delay however caused resulting from the use of this manual can be accepted by Grant Engineering (UK) Limited, the author or others involved in its publication.

All goods sold are subject to our official Conditions of Sale, a copy of which may be obtained on application.

© Grant Engineering (UK) Limited. No part of this manual may be reproduced by any means without prior written consent.

## SOFTWARE HISTORY

As with any software based solution, the Grant Aerona Smart Controller is subject to updates for its operation and functionality.

To view the software version of an installed Grant Aerona Smart Controller, refer to appendix H.1.2 - How to obtain the UID which also displays the current software/firmware versions.

Alternatively (if registered), visit your ecoNET24 account and select 'DEVICE SETTINGS' and refer to 'CONTROLLER SOFTWARE VERSIONS'

Refer to the table below for manual revisions and their related software versions.

Refer to the Grant UK support hub and the TechBox App for access to Grant UK archive of technical manuals.

### Manual revisions & Software versions (R32 & R290)

Manual Revision	Wiring Centre	Touchscreen display
1.0	S002.04	S.002.11
1.1	S002.04	S.002.11
2.0 - 2.1	<b>R290</b> S023.14  <b>R32</b> S003.14	<b>R290</b> S023.20  <b>R32</b> S.003.20
2.2	<b>R290</b> S024.25  <b>R32</b> S004.26	<b>R290</b> S024.22  <b>R32</b> S.004.22
2.3	<b>R290</b> S024.29  <b>R32</b> S004.29	<b>R290</b> S024.24  <b>R32</b> S.004.24

**The Grant QR2 Smart pre-plumbed cylinder range is by default set for operation with the Grant Aerona 290 heat pump.**

**To use with Grant Aerona<sup>3</sup> heat pumps, refer to Section 12.7 to alter the controller software installed.**

# CONTENTS

<b>1</b>	<b>INTRODUCTION</b>	<b>5</b>	<b>5</b>	<b>SMART CONTROLLER</b>	<b>24</b>
1.1	Installation requirements	5	5.1	Touchscreen display	24
1.2	Water supply requirements	5	5.2	Temperature sensors	25
1.3	Location	5	5.3	Connecting pumps	25
1.4	Storage & handling	5	5.4	connecting 3-port mixing valves	26
1.5	About your cylinder	5	5.5	Connecting relays	26
1.6	Open vented hot water systems	5	5.6	Smart flow sensor	26
1.7	Primary circuit pipework connections	6	5.7	Room thermostat connection	26
1.8	Secondary circuit pipework connections	6	5.8	Connecting the Wi-fi Hub	27
1.9	Taps & fittings	6	5.9	Connecting the Modbus	27
1.10	Hard water scaling	6	5.10	Installation Pack	27
1.11	Insulation	6	5.11	Cables	27
1.12	Health & Safety	6			
1.13	System Volumisers	6	<b>6</b>	<b>SYSTEM CONFIGURATION WITH TOUCHSCREEN DISPLAY</b>	<b>28</b>
1.14	Customer support centre	6	6.1	First switch-on	28
<b>2</b>	<b>TECHNICAL DATA</b>	<b>7</b>	6.2	System configuration Creator	28
2.1	Cylinder	7	<b>7</b>	<b>OPERATION &amp; SETTINGS</b>	<b>31</b>
2.2	Smart Controller	7	7.1	Touchscreen display	31
2.3	Product contents	8	7.2	Smart Controller operation	32
2.4	Cylinder dimensions	9	7.3	Circuit settings	32
2.5	Optional plinth dimensions	10	7.4	Legionella protection	34
2.6	Optional Stand dimensions	10	7.5	Time schedules	34
<b>3</b>	<b>INSTALLATION</b>	<b>11</b>	7.6	Heat pump schematic	36
3.1	Grant QR2 Smart Pre-Plumbed Cylinders	11	7.8	Circuit control	36
3.2	Regulations & Standards	11	7.9	User settings menu	39
3.3	Primary connections	11	7.10	Stored system settings	39
3.4	Hard water areas	11	7.11	Secondary circulation	39
3.5	The 2-port valve	11	7.12	System Controls	40
3.6	Secondary Connections	12	7.13	Weather compensation	40
3.7	Cold water inlet manifold	12	7.14	Circuit operation	40
3.8	Installation	13	7.15	Screed Drying	41
3.9	Expansion vessel	13	7.16	Smart Cylinder	42
3.10	Temperature & pressure relief valve	13	<b>8</b>	<b>SERVICE SETTINGS</b>	<b>43</b>
3.11	Hot water supply	13	<b>9</b>	<b>HEAT PUMP PARAMETERS</b>	<b>49</b>
3.12	Prevention of scalding	13	<b>10</b>	<b>WI-FI HUB</b>	<b>50</b>
3.13	Secondary return	13	10.1	General	50
3.14	Tundish	13	10.2	Connection to wiring centre	50
3.15	Discharge pipe	14	<b>11</b>	<b>COMMISSIONING, DRAINING DOWN &amp; SAFETY</b>	<b>52</b>
3.16	Discharge pipe sizing	14	11.1	Filling the Cylinder	52
3.17	Worked example	14	11.2	Draining Down	52
3.18	Discharge pipe arrangement	15	11.3	Immersion Heater Safety Cut-Out	52
3.19	Hose Kits	15	11.4	Cold Water Discharge from Tundish	53
3.20	Pump Over-run protection	15	11.5	Hot Water Discharge from Tundish	53
3.21	Legionella Protection	15	11.6	Expansion Vessel	53
3.22	Automatic bypass	15	11.7	Smart Controller	53
3.22	Hydraulic connections - Aerona <sup>3</sup>	16	11.8	Pump Over-run protection	53
3.23	Hydraulic connections - Aerona 290	17	11.9	Customer Handover	53
<b>4</b>	<b>ELECTRICAL</b>	<b>18</b>	11.10	Health & Safety Information	53
4.1	Mains connection	18	<b>12</b>	<b>SERVICING &amp; MAINTENANCE</b>	<b>54</b>
4.2	Immersion Heater	18	12.1	Cylinder Servicing and maintenance	54
4.3	Immersion heater wiring instructions	18	12.2	Inlet Manifold Assembly	54
4.4	Immersion heater safety cut-out	19	12.3	Expansion Relief Valve	54
4.5	High limit thermostat	19	12.4	Expansion Vessel	54
4.6	2-Port valves	19	12.5	Controller Maintenance	54
4.7	Immersion Override	19	12.6	Updating Controller Firmware	55
4.8	Smart Controller Wiring centre	19	12.7	Converting to Aerona <sup>3</sup>	55
4.9	Cable management	19	<b>13</b>	<b>SPARE PARTS &amp; ACCESSORIES</b>	<b>56</b>
4.10	Factory-fitted Controller- Wiring diagram	20	13.1	Spare parts	56
4.11	Component connections	20	13.2	Accessories	56
4.12	Power supply failure	20			
4.13	Switch relays	20			
4.14	Wiring centre Layout	21			
4.15	Electrical connections - Aerona <sup>3</sup>	22			
4.16	Electrical connections - Aerona 290	23			

<b>14</b>	<b>FAULT FINDING</b>	<b>57</b>	<b>APPENDIX J - EVOLINK SMART</b>	<b>86</b>	
14.1	Intermittent water discharge	57	J.1	Evolink Smart	86
14.2	Constant water discharge	57	J.2	Parameters	86
14.3	No flow from hot water taps	58	J.3	Operation	87
14.4	Cold water flow from hot water taps	58	J.4	Adjusting the EvoLink Smart	87
14.5	Excessive Hot water from taps	59	J.5	Heat pump (MHS) Override	87
14.6	Smart Controller	59			
<b>15</b>	<b>PRODUCT FICHE</b>	<b>61</b>	<b>ONLINE RESOURCES</b>	<b>88</b>	
<b>16</b>	<b>END OF LIFE</b>	<b>61</b>	<b>INSTALLATION, COMMISSIONING &amp; SERVICE RECORD LOG BOOK</b>	<b>89</b>	
16.1	General	61	<b>NOTES</b>	<b>93</b>	
16.2	Disassembly	61			
16.3	Recycling	61			
16.4	Disposal	61			
16.5	Directive WEEE 2012/19/EU	61			
<b>17</b>	<b>DECLARATION OF CONFORMITY</b>	<b>62</b>			
<b>18</b>	<b>GUARANTEE</b>	<b>63</b>			
	<b>APPENDIX A - WIRED THERMOSTAT</b>	<b>65</b>			
A.1	General	65			
A.2	Installation	65			
A.3	Thermostat panel	65			
A.4	pairing	66			
A.5	Changing setpoint temperature	66			
A.6	User Menu	66			
A.7	Error codes	67			
A.8	Technical data	67			
	<b>APPENDIX B - WIRELESS THERMOSTAT &amp; RECEIVER</b>	<b>68</b>			
B.1	General	68			
B.2	Installing Wireless receiver	68			
B.3	Wireless thermostat	69			
B.4	Multiple thermostat support	69			
B.5	Thermostat Panel	70			
B.6	User Menu	70			
B.7	Memory reset of the wireless receiver	70			
B.8	Alarms	70			
B.10	Technical data	71			
	<b>APPENDIX C - 3-PORT MIXER VALVE</b>	<b>72</b>			
C.1	General	72			
C.2	Clockwise rotation	72			
C.3	Anti-Clockwise rotation	73			
	<b>APPENDIX D - HEATING ASSISTANCE</b>	<b>74</b>			
D.1	General	74			
D.2	Wiring	74			
D.3	Legionella Protection	74			
D.4	Supplementary heating	75			
D.5	Defrost assistance	75			
	<b>APPENDIX E - SMART FLOW SENSOR</b>	<b>76</b>			
E.1	General	76			
E.2	Installation	76			
E.3	Electrical	77			
E.4	Sensor configuration	77			
	<b>APPENDIX F - COMMISSIONING CHECKLIST</b>	<b>78</b>			
	<b>APPENDIX G - AERONA<sup>3</sup> (R32)</b>	<b>80</b>			
G.1	General	80			
G.2	Serial Number	80			
G.3	Existing Controls	80			
G.4	Underfloor Heating controls	80			
G.5	Connecting the Modbus	80			
G.6	Aerona <sup>3</sup> Frost protection	81			
G.7	Service Alarm	81			
G.8	Immersion Relay	81			
G.9	Aerona <sup>3</sup> R32 Heat pump parameters	82			
	<b>APPENDIX H - ECONET</b>	<b>84</b>			
H.1	Econet24	84			

# 1 INTRODUCTION

## 1.1 INSTALLATION REQUIREMENTS

Thank you for purchasing a Grant Smart pre-plumbed storage cylinder from our QR2 range. This Smart cylinder is designed for use with Grant Aeron heat pumps only.

This cylinder conforms to the requirements of BS EN 12897:2016+A1:2020. Water supply - specification for indirectly heated unvented (closed) storage water heaters.

These Installation and User instructions must be read carefully before you begin installing the Smart cylinder.

The cylinder must be installed by a competent person in compliance with all current legislation, codes of practice and local by-laws covering the installation of an unvented hot water cylinder.

Please also make sure that the installation complies with the information contained in these Installation and User Instructions.

To prevent damage to the coil, cylinder and cylinder connections, make any soldered joints before connecting pipework to the cylinder.

## 1.2 WATER SUPPLY REQUIREMENTS

We recommend that your Grant QR2 Smart pre-plumbed cylinder is installed with an uninterrupted water supply.

Where possible, the unit should be fed via a Ø22 mm supply pipe. It requires a supply pressure of at least 1.5 bar with a flow rate of at least 25 litres per minute as a minimum for it to function.

Even with this pressure and flow rate, the flow from the outlets will be disappointing if several outlets are used simultaneously. Generally speaking, the higher the supply pressure, the better the system will function.

The cylinder control equipment as factory supplied is set to limit the incoming system operating pressure to 3 bar. The maximum supply pressure into the pressure reducing valve (PRV) is 12 bar.

## 1.3 LOCATION

The unit is designed to be floor standing, vertically mounted, internally in a frost-free environment. When choosing a suitable location for the cylinder, consideration should be given to the routing of the discharge pipe to a convenient point and also the availability of single 20A power supply for connecting the Grant QR2 Smart cylinder wiring centre.

The cylinder may stand on any flat and level surface without any special foundation requirements, provided that it is sufficiently robust to support the full weight of the cylinder (refer to Section 2.1).

The position of the cylinder should be such that easy access is provided for servicing the controls and replacing the immersion heater should the need arise.

Generally, pipe runs should be made as short as possible and lagged to prevent heat loss.

Should it be required, a plinth for the cylinder is available to purchase from Grant UK (product code: MB-29) to enable pipework to be run underneath the cylinder with ease. Refer to Section 2.4 for dimensions.

## 1.4 STORAGE & HANDLING

If the cylinder is not being installed immediately, it should remain in its carton to prevent damage. We recommend that the cylinder be transported to its installation position on a sack truck or similar whilst still within the carton.

### ! CAUTION !

**Do not use the Temperature and Pressure relief valve (T&P relief valve) as a handle when moving and positioning the cylinder.**

**With pre-plumbed cylinders, do not use the pipework as a carrying handle when lifting, moving and positioning the cylinder.**

## 1.5 ABOUT YOUR CYLINDER

Grant QR2 Smart pre-plumbed cylinders are factory-fitted with the following components:

### Primary circuit pipework

- 1 x 22mm 2-port zone valve for hot water
- 2 x 22mm 2-port zone valves for heating (for two separate heating zones)
- 1 x Manual air vents (on heat pump flow pipe coil)
- 1 x 15mm approved filling loop

### Cold water inlet pipework

- 1 x Cold water inlet manifold
- 1 x Temperature and pressure relief valve
- 1 x 15-22mm Tundish
- 1 x Drain cocks (at bottom of cylinder)

### Electrical Housing

- 1 x Touchscreen display
- 1 x Controller wiring centre (pre-wired to the touchscreen display, 2-port zone valves, zone valve for DHW, 20A relay for immersion heater and Cylinder water temperature sensor)
- 1 x 3kW electric immersion heater
- 1 x High limit thermostat
- 2 x MCB (B rated 16A for Immersion, 6A for Smart controller)
- Immersion override switch

Grant QR2 Smart pre-plumbed indirect heat pump cylinders have a single coil designed for connection to a Grant Aeron heat pump.

The coil must be connected using the 2-port zone valve (factory-fitted) to shut off the flow from the primary source and electronically interlocked with the heat source via the cylinder control and high limit thermostat.

Failure to use the 2-port zone valve will invalidate all guarantees and will be in breach of the Building Regulations Approved Document G3 (2010). More information on electrical wiring is given in Section 5 of these instructions.

Grant QR2 Smart pre-plumbed cylinders are factory-fitted with a temperature and pressure relief (T&P) valve and a 3kW electric immersion heater.

Please refer to Figure 2-2 for positions of the components fitted to these cylinders.

Refer to Sections 4.2 to 4.4, and 11 for further details on immersion heaters.

## 1.6 OPEN VENTED HOT WATER SYSTEMS

If required, your Grant QR2 Smart indirect heat pump cylinder can be used as part of an open vented hot water system, i.e. fed from a cold water storage cistern and fitted with an open vent pipe, provided the maximum head does not exceed 30 metres.

When used in this way, it will not be necessary to install the expansion vessel and cold water inlet manifold supplied with the cylinder.

### ! NOTE !

**The temperature and pressure relief (T&P) valve must be left connected to the cylinder (as supplied).**

As it may still operate due to temperature, the temperature and pressure relief (T&P) valve should be connected in the correct manner - refer to guidance given in Section 3.6 of these instructions.

## 1.7 PRIMARY CIRCUIT PIPEWORK CONNECTIONS

All primary circuit pipework connections to the cylinder MUST be made in accordance with Figure 3-1. Refer to Section 3 (Primary Connections).

## 1.8 SECONDARY CIRCUIT PIPEWORK CONNECTIONS

All secondary circuit primary pipework connections to the cylinder MUST be made in accordance with Figure 2-2 and Section 3.6.

## 1.9 TAPS & FITTINGS

All taps and fittings incorporated in the unvented hot water system should have a rated operating pressure of 7 bar or above.

The compression nut and olive required for the hot water draw-off connection and the blanking plug for the secondary return connection are supplied fitted.

The 28mm compression connectors required for the heat pump flow and return connections, and the system return connection, are also supplied fitted to the cylinder pipework.

# ! NOTE !

**Ensure that all fittings (including fittings on pre-plumbed pipework) are tightened to ensure a watertight seal as part of commissioning.**

## 1.10 HARD WATER SCALING

If the cylinder is used in a hard water area scaling will form inside the cylinder and this will reduce both the performance and working life of the cylinder.

Where the total hardness exceeds 125 ppm a high capacity water softener, or suitable water conditioner, should be installed in the incoming cold water supply to the cylinder.

The cylinder immersion heater control thermostat has been factory-set to around 61.5°C(±3°C). Please refer to Section 4.2 for further information on the immersion heater supplied.

The water temperature control thermostats (on the immersion heaters and Smart Controller) fitted to the cylinder should be set no higher than 65°C, however this could be decreased to be between 60°C and 65°C depending on the end user's requirements.

Setting a lower target temperature will help to minimise the build-up of lime scale and is likely to increase the longevity of the hot water cylinder.

## 1.11 INSULATION

All Grant QR2 Smart pre-plumbed indirect heat pump cylinders are insulated with a 50mm layer of CFC/HCFC free, fire retardant, polyurethane foam injected between the stainless steel cylinder and the outer casing. This polyurethane foam has a Global Warming Potential (GWP) of 3.1 and an Ozone Depletion Potential (ODP) of 0.

## 1.12 HEALTH & SAFETY

The information supplied in Table 2-1 will help you assess the safest way to manoeuvre your cylinder into position.

Please use the table to find the empty weight of your cylinder and then consider how you can safely move it into its final position.

Please leave these Installation and User Instructions with the householder after installation.

- Requirements concerning safety are listed in particular Sections of this instruction manual. Apart from these it is necessary to fulfil the following requirements:
- Before starting the installation, repairs or maintenance and during the execution of any connection works, it is necessary to switch off the mains power supply and make sure that no terminals and electrical wires are live.
- Even after turning off wiring centre terminals it can still be under a dangerous level of voltage.
- The controller can be utilised only in accordance with its intended use.

- Additional measures should be used in order to protect the central heating and DHW system against the results of controller failure or software errors. Particularly control measures which reduce DHW temperature in order to protect users against burns.
- Parameters should be set in accordance to the heating system design.
- The controller is not an intrinsically safe device. It means that in case of failure it can be a source of sparks or high temperature which can cause fire or explosion.
- Modification of the programmed parameters should be made only by the installer.
- Use only in central heating system made in accordance with currently valid regulations.
- Electrical system including the controller should be 3-wired and protected with fuse selected in accordance with used loads.
- The controller components cannot be used with damaged housing.
- Never make any modifications in controller components structure.
- Keep children away from the controller.

## 1.13 SYSTEM VOLUMISERS

Grant UK offer a variety of volumisers for use with the Grant range of Heat pumps and cylinders.

- **Grant External Volumiser (30L)**  
The Grant External 30 litre volumiser is an insulated rectangular tank fitted with a single 3kW electric immersion heater and is designed for use externally with the Grant Aerona<sup>3</sup> R32 air source heat pumps only. This is housed within a weatherproof external casing with a removable cover at one end to access the electrical connections and immersion heater.
- **Grant Combined Volumiser/Low-Loss Header (11.5L)**  
The Grant Combined volumiser/low loss header provides the functions of both a volumiser and low loss header in one unit, with an integral 3kW electric immersion heater, for use with Grant Aerona<sup>3</sup> and Grant Aerona 290 air source heat pumps.
- **Grant Internal Volumiser (50L)**  
The Grant Internal volumiser is an insulated cylindrical tank fitted with a single 3kW electric immersion heater, for use with Grant Aerona<sup>3</sup> and Grant Aerona 290 air source heat pumps. It is primarily designed to sit underneath a Grant QR2 cylinder, with the cylinder placed on a purpose built stand with space to safely house the volumiser underneath.

## 1.14 CUSTOMER SUPPORT CENTRE

Grant UK provides an online support centre for Heating Professionals and Homeowners to access post-installation care, advice and maintenance support for Grant products. Follow the QR codes below to access your relevant Customer Support Centre.



Homeowner



Professional

## 2 TECHNICAL DATA

### 2.1 CYLINDER

**Table 2-1:** Cylinder Technical Data

	Grant QR2 Smart pre-plumbed indirect heat pump cylinders			
	180 litre	210 litre	250 litre	300 litre
Nominal capacity (litres)	180	210	250	300
Actual capacity (litres)	168	198	238	288
Overall diameter (mm)	561	561	561	561
Overall height (mm)	1354	1541	1792	2103
Weight - empty (kg)	46	51	56	61.5
Coil capacity (litres)	11	11	11	11
Total weight full - incl coil (kg)**	225	260	305	360.5
Secondary return connection (mm)	22	22	22	22
Cold feed / hot draw-off connections (mm)	22	22	22	22
Primary coil connections (mm)	22	22	22	22
Primary coil length (m)	18.5	18.5	18.5	18.5
Primary coil surface area (m <sup>2</sup> )	3.2	3.2	3.2	3.2
Primary coil pipe diameter (mm)	28	28	28	28
Maximum water supply pressure (bar)	12	12	12	12
System operating pressure - pre-set (bar)	3	3	3	3
Expansion vessel charge pressure (bar)	3	3	3	3
Expansion relief valve pressure (bar)	6	6	6	6
T&P relief valve lift pressure (bar)	7	7	7	7
T&P relief valve lift temperature (°C)	90	90	90	90
Maximum primary circuit working pressure (bar)	2.5	2.5	2.5	2.5
<b>Performance:</b>				
Primary coil rating (kW)	42.14	39.58	36.17	31.90
Standing heat loss (kWh/24hrs)*	1.21	1.41	1.54	1.81
Standing heat loss (W)*	50	59	64	75
ERP rating	B	B	B	C

\* Test carried out at 60°C.

\*\*Total weight full = Weight empty + Actual capacity + Coil capacity.

### 2.2 SMART CONTROLLER

**Table 2-2:** Technical Data

Wiring Centre (Factory-fitted)	
Power supply	230V AC, 50Hz
Controller current consumption	0.4 A <sup>3</sup>
Maximum rate current	6 (6) A
Protection class	IP 20 <sup>4</sup>
Relative humidity	5 to 85% without water vapour condensation
Outdoor Weather Sensor working range	-40 to 110° C
Measurement accuracy: Water & Outdoor Weather Sensors	±2° C
Wiring centre dimensions	234mm x 225mm x 64mm
Standards	EN 60730-2-9. EN 60730-1
Software class	A, according to EN 60730-1

<sup>3</sup> Current consumed only by the controller. Overall current consumption depends on number of devices

<sup>4</sup> After installing all cable clamps.

**Table 2-3: Technical Data - Touch screen Display**

Touch screen Display	
Power supply	12V DC directly the Wiring centre
Touch screen display current consumption	0.15A
Display	Touch screen, graphical 480px x 272px
Protection class	IP 20
Ambient temperature	0 to 50° C
Relative humidity	0 to 65° C
Touch screen display dimensions	144mm x 97mm x 20mm
Standards	EN 60730-2-9, EN 60730-1
Software class	A, according to EN 60730-1
Installation method	Wall mounted

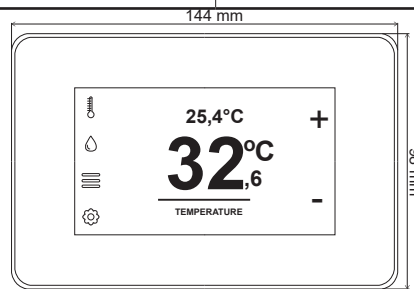
**Figure 2-1: Touch screen display dimensions**

### 2.3 PRODUCT CONTENTS

**Table 2-4: Product contents for models - QR2SMART180PP/QR2SMART210PP/QR2SMART250PP/QR2SMART300PP**

	Grant QR2 Smart pre-plumbed indirect heat pump cylinders			
	180 litre	210 litre	250 litre	300 litre
Cylinder assembly	1	1	1	1
Expansion vessel - 18 litre (G3/4" M)	1	1	1	-
Expansion vessel - 25 litre (G3/4" M)	-	-	-	1
1/2" Temperature and PRV - 7 bar/90°C - 15mm compression fitting (Factory-fitted)	1	1	1	1 (3/4")
Tundish - 15/22 mm (Factory-fitted)	1	1	1	1
22mm compression nut and olive (Factory-fitted)	4	4	4	4
28 mm compression connector (Factory-fitted)	3	3	3	3
3/4" BSPM x 22mm compression adapter	1	1	1	1
3/4" BSPF x 22mm compression adapter	1	1	1	1
1/2" Drain cock c/w hose connector (Factory-fitted)	1	1	1	1
Inlet manifold - 3 bar PRV and 6 bar expansion relief valve (Factory-fitted)	1	1	1	1
2-port motorised valve - 22 mm (Factory-fitted)	3	3	3	3
Immersion heater - 3kW 1 3/4" boss (Factory-fitted)	1	1	1	1
Smart Controller wiring centre (Factory-fitted)	1	1	1	1
Touchscreen display (Factory-fitted)	1	1	1	1
Water temperature sensor (DHW) (Factory-fitted)	1	1	1	1
<b>Smart Controller Kit</b>				
<b>HP32SMAR6PP/HP32SMAR10PP/HP32SMAR1317PP (Aerona<sup>®</sup>)</b>				
Wi-Fi Hub kit	1	1	1	1
Outdoor weather sensor (with fixings)	1	1	1	1
Water temperature sensors (4m cable)	2	2	2	2
Flow sensor	1	1	1	1
Flexible hoses	2	2	2	2
Isolation valves	4	4	4	4
<b>HP290SMARTPP (Aerona 290)</b>				
Wi-Fi Hub kit	1	1	1	1
Outdoor weather sensor (with fixings)	1	1	1	1
Water temperature sensors (4m cable)	2	2	2	2
<b>Flexible hoses and valves available (R290 only)</b>				
HPHOSEKIT - Flexible hoses and 28 mm ball valves	2	2	2	2
HPHOSEKITPRO - Flexible hoses (Primary Pro insulated) and 28 mm long stem ball valves & sealant	2	2	2	2

2.4 CYLINDER DIMENSIONS

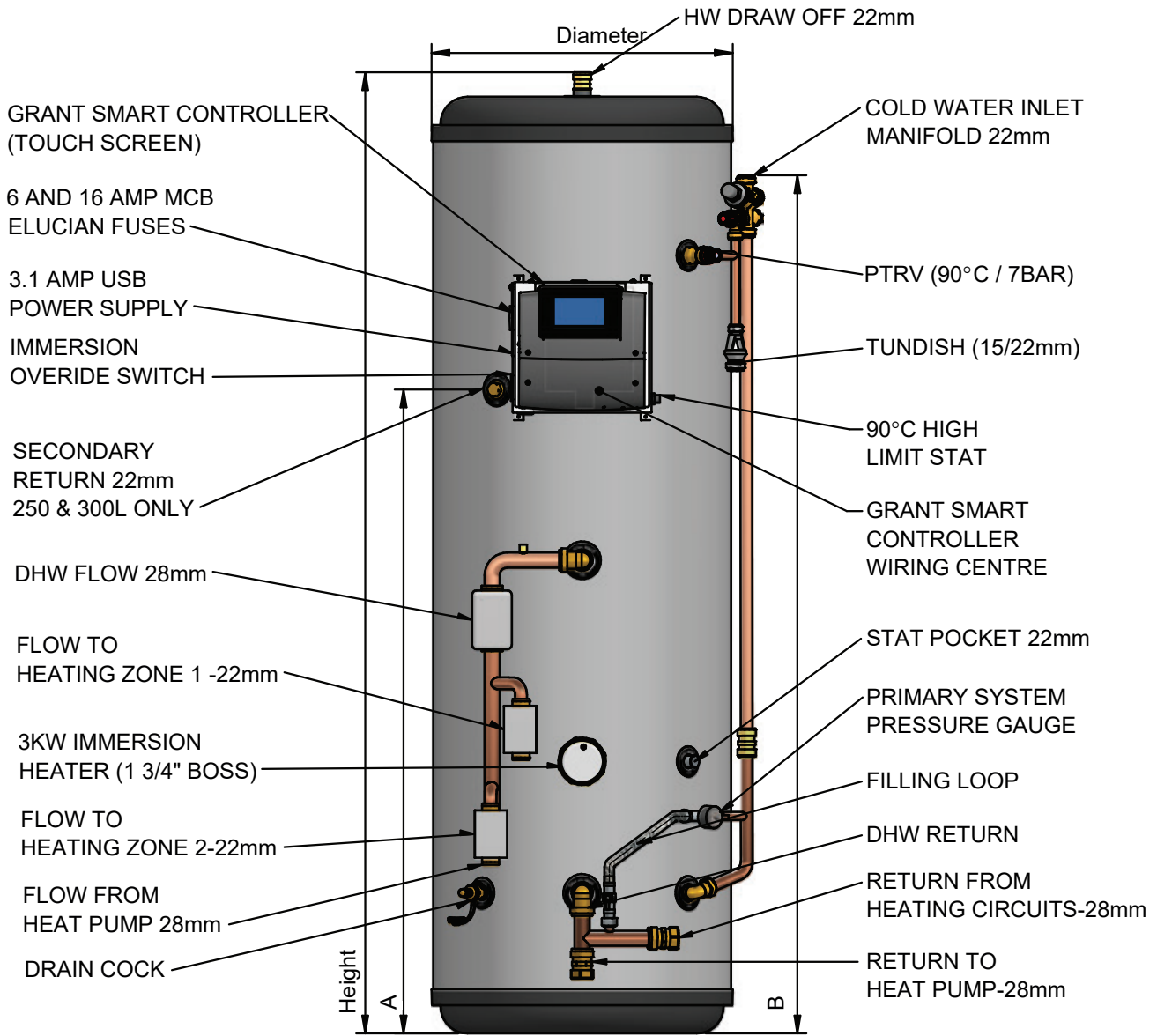
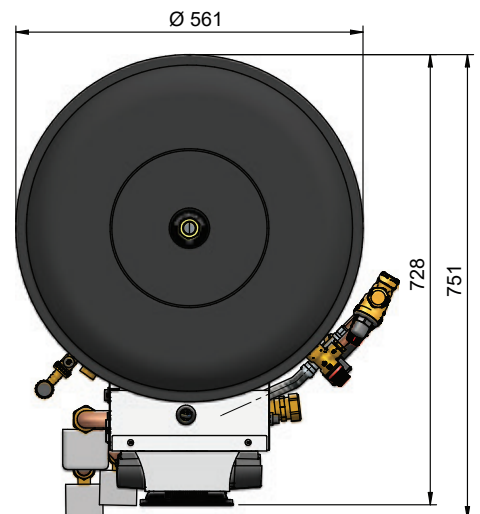

Figure 2-2: Grant QR2 Smart pre-plumbed indirect heat pump cylinder dimensions

Table 2-5: Grant Smart Pre-plumbed cylinder dimensions

Dimensions (mm)	180 litre	210 litre	250 litre	300 litre
A*	-	-	1200	1511
B	1159	1354	1601	1940
Height	1354	1541	1792	2103
Diameter	561	561	561	561

\* Secondary return on 250 and 300 litre models ONLY



## 2.5 OPTIONAL PLINTH DIMENSIONS

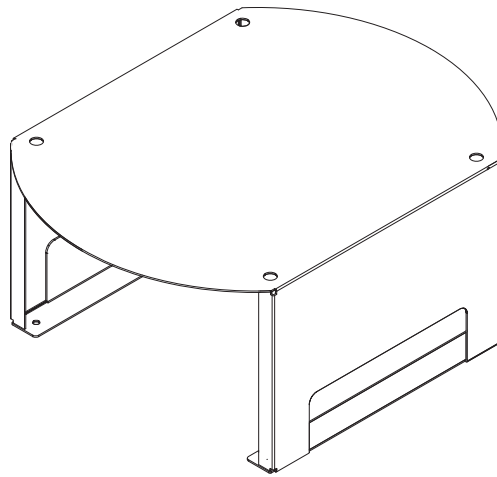

**Figure 2-3:** Grant QR2 Smart Cylinder Plinth (product code: MB-29)

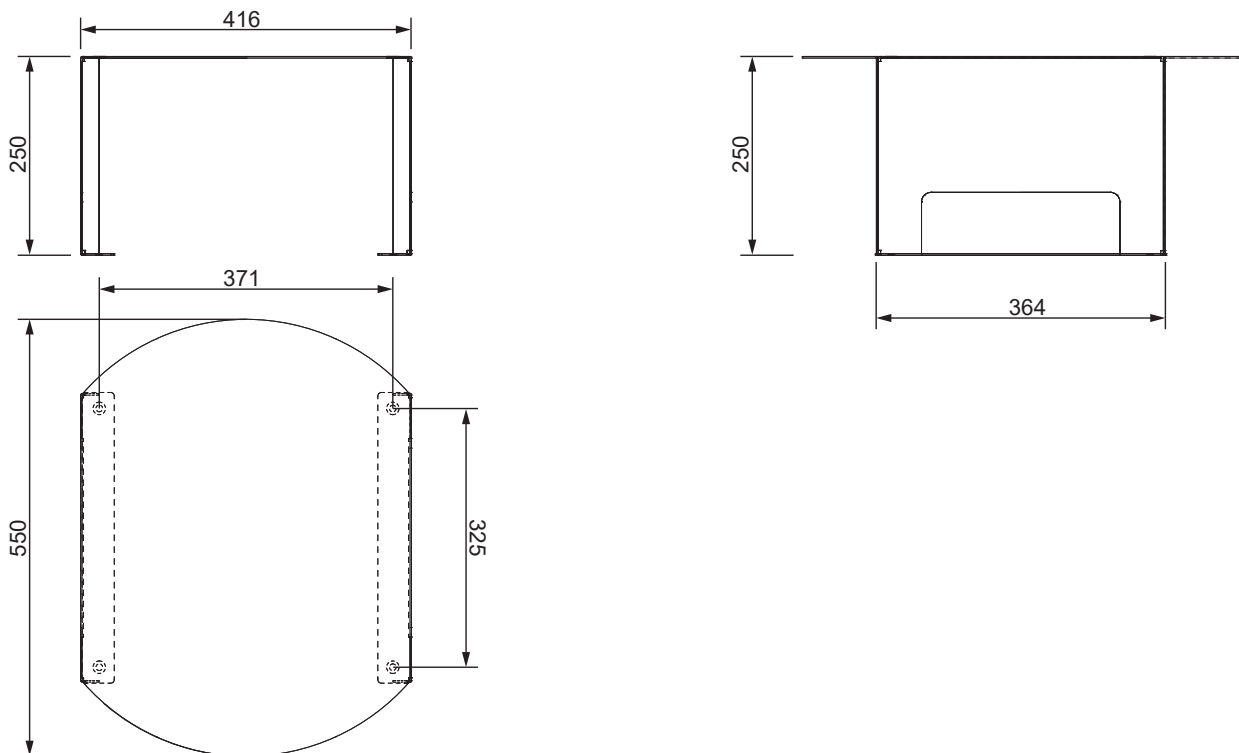

**Figure 2-4:** Grant QR2 Smart Cylinder Plinth dimensions

## 2.6 OPTIONAL STAND DIMENSIONS

Grant offer an optional stand for cylinders when installing an internal volumiser. Refer to figure 2.5.

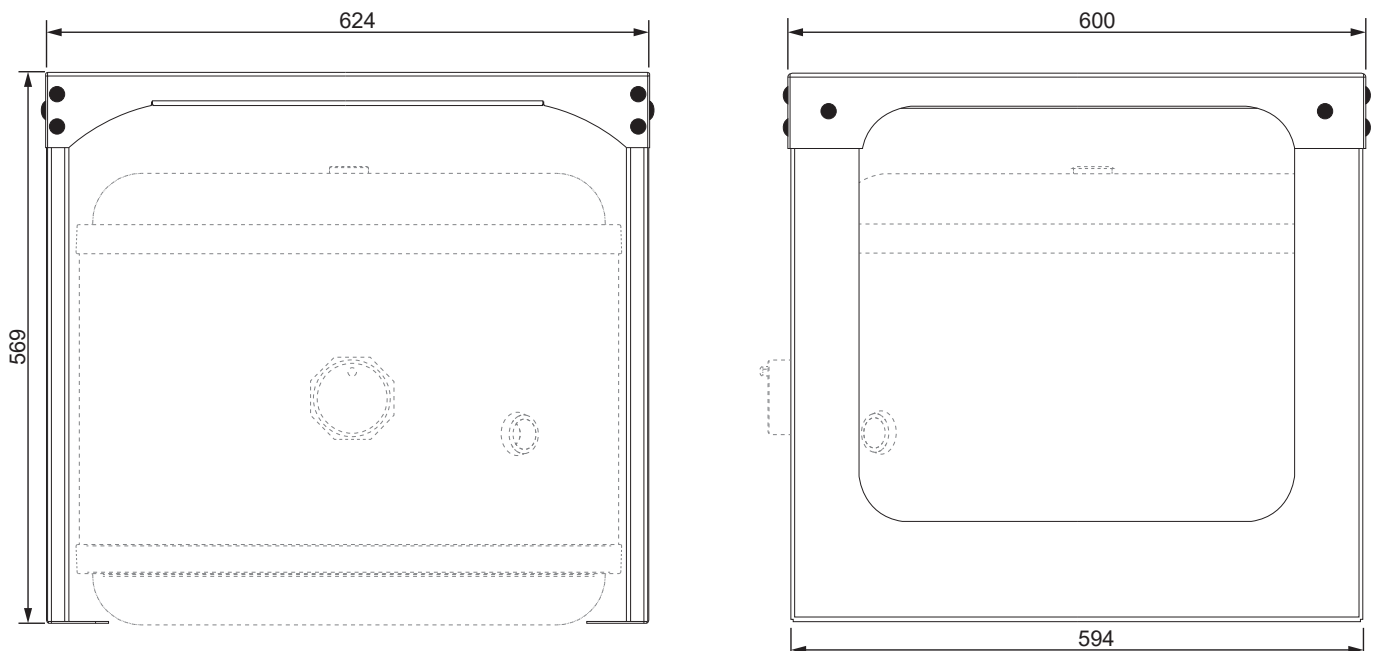

**Figure 2-5:** QR2 Cylinder stand for 50L internal volumiser (product code: MB-50)

# 3 INSTALLATION

## 3.1 GRANT QR2 SMART PRE-PLUMBED CYLINDERS

Grant QR2 Smart pre-plumbed cylinders are specifically designed for connection to a Grant Aerona Heat Pump with a maximum working pressure of 3.5 bar and a maximum working temperature of 90°C.

## 3.2 REGULATIONS & STANDARDS

The installation of the Grant QR2 Smart pre-plumbed cylinder for use with a Grant Aerona air source heat pump must be in accordance with the following recommendations, as applicable:

- National Building Regulations, e.g. Approved Documents L & G
- Local Bylaws (Check with the Local Authority for the area)
- Water Supply (Water Fittings) Regulations 1999
- MCS Installers Standards (when required, e.g. for installations for the Boiler Upgrade Scheme).
- MIS 3005 - I. The Heat Pump Standard - Installation.
- MIS 3005 - D. The heat pump Standard - Design.
- MCS 020. MCS Planning Standard

The installation should also be in accordance with the latest edition of the following standards and codes of practice:

- BS 7671 and Amendments. Requirements for Electrical Installations. IET Wiring Regulations.
- BS EN 12831. Energy performance of buildings. Method for calculation of the design heat load. Space heating load.
- BS 7593. Code of practice for the preparation, commissioning and maintenance of domestic central heating and cooling water systems.

## 3.3 PRIMARY CONNECTIONS

Grant QR2 Smart pre-plumbed cylinders are factory-fitted with primary circuit pipework that includes the following components:

- 1 x 2-port zone valve for hot water
- 2 x 2-port zones valves for heating (for two separate heating zones)
- 1 x High Limit thermostat
- 1 x Manual air vents (on heat pump flow pipe coil)
- 1 x Approved filling loop to fill the primary circuit

Make the primary circuit and heat pump connections to the cylinder as follows (Refer to Figure 3-1):

1. The primary flow and return connections from the heat pump should be made to cylinder connections A and D respectively (refer to Figure 3-1 and Table 3-1).
2. The primary flow to heating zone 1 should be made to cylinder connection C (refer to Figure 3-1 and Table 3-1).
3. The primary flow to heating zone 2 should be made to cylinder connection B (refer to Figure 3-1 and Table 3-1).
4. When filling the primary circuit, the manual air vents situated on the flow and return connections to the indirect coil can be used to vent air from the indirect coil (refer to item F in Figure 3-1).

## 3.4 HARD WATER AREAS

If the cylinder is to be used with a boiler, in a hard water area, we recommend that the primary flow temperature be limited to 75°C.

This will help reduce the migration of suspended solids in the water and help prevent the build up of lime scale.

## 3.5 THE 2-PORT VALVE

To prevent gravity circulation when the heat pump switches off, three 2-port motorised valves have been supplied fitted to the cylinder after the primary flow pipe from the ASHP (see item D, Figure 3-1). They are pre-wired in accordance with Figures 4-4 & 4-5 to ensure that, when used with a Grant Aerona Heat Pump, the installation will comply with current legislation.



**Figure 3-1:** Grant QR2 Smart Pre-plumbed system connections

**Table 3-1:** Key to Figure 3-1

Item	Description
A	28mm Flow from ASHP
B	22mm Flow to heating zone 2
C	22mm Flow to heating zone 1
D	28mm Return to ASHP
E	28mm Return from heating circuits
F	Manual air vent

### 3.6 SECONDARY CONNECTIONS

Grant QR2 Smart pre-plumbed indirect heat pump cylinders are supplied with all the necessary safety devices and components required for an unvented hot water system. For a list of these safety devices and components refer to Table 2-4 in these Installation and User instructions.

These pre-plumbed cylinders are supplied with the safety devices and components factory-fitted, requiring only the following to be carried out by the installer:

- Connect the cold water supply pipe to the cold water inlet manifold. Refer to Sections 3.7 and 3.8 for details.
- Connect the expansion vessel. Refer to Sections 3.8 and 3.9 for details.
- Connect the discharge pipe to the outlet of the Tundish. Refer to Section 3.14 for details.

For commissioning and maintenance purposes, it is essential to

fit a service valve (not supplied) in the cold water supply pipe, immediately before the inlet manifold.

The 1/2" drain cock is factory-fitted (refer to Figure 2-2 for location) in the cold feed to the cylinder to provide a means of draining the unit. Refer to Figures 2-2 for a suitable drain cock position that will enable most of the cylinder to be drained off when required.

### 3.7 COLD WATER INLET MANIFOLD

This manifold contains a pressure reducing valve, double check valve and expansion relief valve with a stainless steel seat.

The pressure reducing valve is factory set to 3 bar. The set pressure is shown on top of the valve. The maximum inlet pressure to this valve is 12 bar.

A balanced cold water connection is provided on the inlet manifold. Refer to Figure 3-3. This should only be used to provide balanced cold supplies to shower valves and mixer taps. If the balanced cold water outlet is not required, blank off this port.

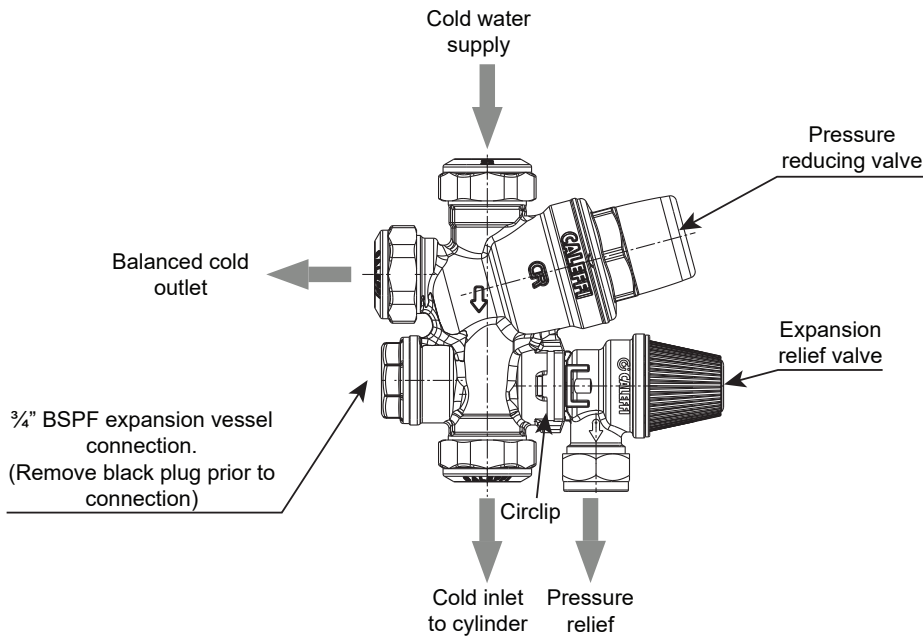

Figure 3-3: Cold water inlet manifold

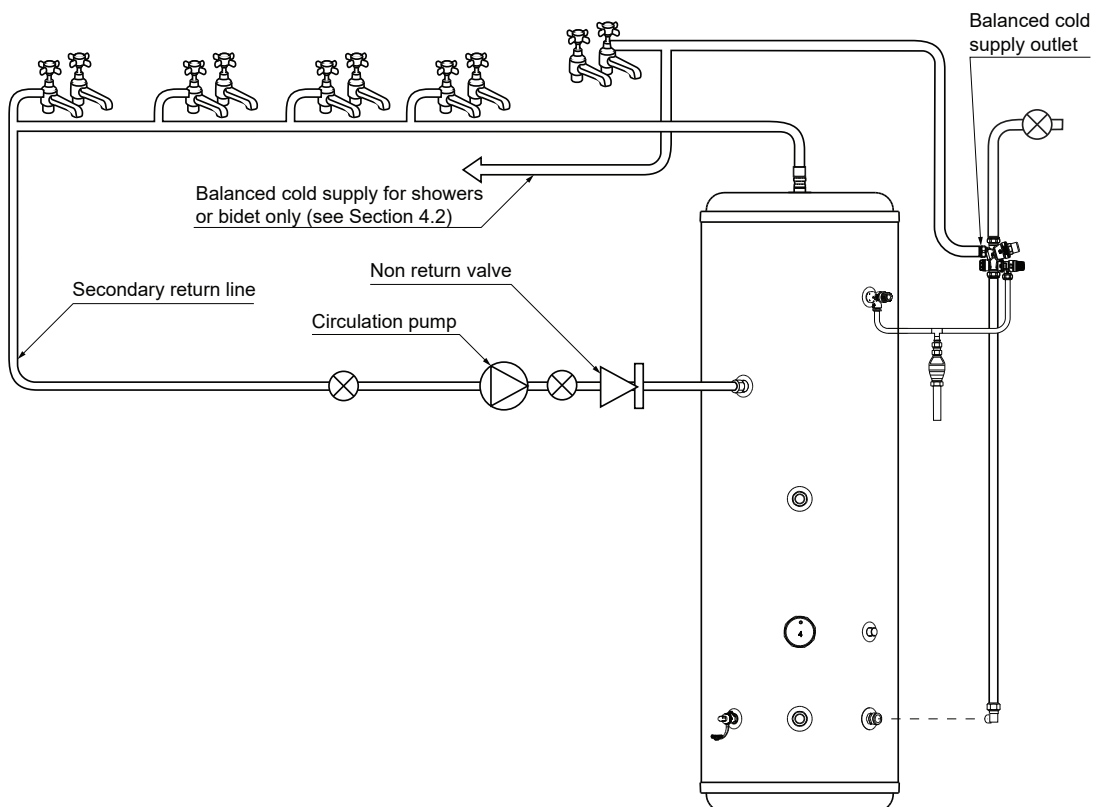

Figure 3-4: Secondary return circuit

### 3.8 INSTALLATION

1. Cold water supply pipe to be 22mm nominal size.
2. Flush supply pipework before connection to remove all flux and debris prior to connecting the water supply.  
Failure to do this may result in irreparable damage to the controls and will invalidate the warranty.
3. Once the pipework is flushed connect the cold supply to the Inlet manifold. Refer to Figure 2-2 for location and Figure 3-3 for a detailed drawing of the manifold. A service valve (not supplied) must be fitted in the cold supply to the cylinder before this connection is made.
4. The expansion relief valve should be either horizontal or upright - if fitted inverted, debris may be deposited on the seat and cause fouling of the seat when the valve operates. Check direction of flow arrows.
5. If the installation requires one, a pressure gauge should be sourced and fitted on the cold water supply to the cylinder, between the inlet manifold and the cold water inlet tapping on the cylinder.
6. Connect the expansion vessel directly to the 3/4" BSPF connection in the inlet valve manifold body, after removing the black plastic plug (see Figure 2-2 for location and Figure 3-3 for a detailed drawing of the manifold). Refer to Section 3.9 for more information on fitting the expansion vessel.
7. The expansion relief drain and the T&P relief valve are both connected to the tundish (see Figure 2-2). This pipework must be connected to a safe visible discharge point via the tundish (supplied fitted) and the pipework must have a continuous fall. Refer to Sections 3.14 to 3.18 for further information on the Tundish and Discharge pipe.
8. The pressure reducing valve has two outlets, the first being the cold supply to the cylinder; the second one is for a balanced cold water supply (Refer to Figure 3.3), to a shower or a bidet (over rim type only, ascending spray type requires type AA, AB or AD air gap).  
Major shower manufacturers advise fitting a mini expansion vessel in the balanced cold supply to accommodate thermal expansion and prevent tightening of shower controls.  
If the dwelling has a shower mixing valve (manual or thermostatic) or a Bidet (over rim type) use the cold water supply from the balanced cold water connection on the inlet manifold for these outlets.  
Do not use the balanced cold connection to supply bath taps as this can reduce the flow of water available to the cylinder.  
If the balanced cold water outlet is not required, blank off the connection.
9. The Service Log at the back of these instructions should be completed after commissioning of the system.

The cylinder must be registered with Grant UK within 30 days of installation. Refer to Section 18 for further details on the Cylinder guarantee.

### 3.9 EXPANSION VESSEL

A suitable expansion vessel with a pre-charge pressure of 3bar is supplied for fitting to all cylinders.

This expansion vessel must be connected into the cold water supply, between the expansion relief valve (in the inlet manifold) and the cold water inlet to the cylinder. Refer to Figure 3.3.

The preferred method of connection is to hard pipe the expansion vessel directly to the 3/4" BSPF connection in the inlet valve manifold body using 22mm diameter pipe. Refer to Figure 3-3.

To do this, with the cylinder in its final position and with all primary circuit connections to the cylinder made:

1. Remove the black plastic plug from the inlet manifold body (refer to Figure 3-3).
2. Screw the 3/4" BSPM x 22mm compression adapter (supplied) into the 3/4" BSPF connection in the inlet manifold body.
3. Mount the expansion vessel in a suitable position on an adjacent wall to the cylinder using the wall brackets on the vessel.

## ! NOTE !

**The expansion vessel must be positioned with the connection point at the bottom.**

**No valve should be fitted between the expansion vessel and the cylinder.**

4. Using 22mm diameter pipe and the 22mm compression nut and olive supplied with the expansion vessel, connect the expansion vessel to the inlet manifold.

The air charge pressure in the expansion vessel must be regularly checked (e.g. at every service) and topped up as necessary. The correct air charge pressure is 3.0bar.

Refer to Sections 12.1 & 12.4 for further details.

### 3.10 TEMPERATURE & PRESSURE RELIEF VALVE

The temperature and pressure relief valve (T&P Valve) is supplied factory-fitted to the cylinder. The T&P valve must not be removed from the cylinder or tampered with in any way. The valve is pre-set to lift at 7bar or 90°C and any attempt to adjust it will invalidate the guarantee.

### 3.11 HOT WATER SUPPLY

Connect the hot water supply pipe to the top outlet of the cylinder. Refer to Figure 2-2.

### 3.12 PREVENTION OF SCALDING

Building Regulations Approved Document G (Part G3) requires that the hot water temperature supplied to a bath should be limited to a maximum of 48°C by using an in-line blending valve (not supplied with the cylinder) with a maximum temperature stop.

The length of the supply pipe between the blending valve and the bath hot water outlet should be kept to a minimum to prevent the colonisation of waterborne pathogens (e.g. Legionella). Refer to Approved Document G for further details.

### 3.13 SECONDARY RETURN

Grant QR2 Smart pre-plumbed indirect heat pump cylinders with a storage volume of 250 and 300 litres are fitted with a secondary return connection.

If a secondary return circuit is required it should be connected to the cylinder as shown in Figure 3-4.

## ! NOTE !

**If a secondary circulation circuit is installed then a larger expansion vessel may be required to handle the increase in volume. Contact Grant UK for guidance if necessary.**

### 3.14 TUNDISH

A suitable tundish is supplied fitted to the outlets from the T&P relief valve and expansion relief valve.

The tundish should be vertical, located in the same space as the unvented hot water cylinder and be fitted as close to, and lower than, the T&P valve with no more than 600mm of pipe (D1) between the valve outlet and the tundish. Refer to figure 3-5.

## ! WARNING !

**The tundish must NOT be positioned above or in close proximity of any electrical current carrying devices or wiring.**

A discharge pipe must be fitted to the outlet of the tundish. This must conform to the requirements as given in Sections 3.15 to 3.18 of these Installation and User Instructions.

### 3.15 DISCHARGE PIPE

1. The discharge pipe (D2) from the tundish should terminate in a safe place where there is no risk to persons in the vicinity of the discharge.
  - a) It should be made of metal or other material that has been demonstrated to be capable of withstanding temperatures of the water discharged.
  - b) Be at least one pipe size larger than the normal outlet size of the safety device unless its total equivalent hydraulic resistance exceeds that of a straight pipe 9m long, i.e. for discharge pipes between 9m and 18m long the equivalent resistance length should be at least two sizes larger than the normal outlet size of the safety device, between 18m and 27m at least three sizes larger and so on.  
Bends must be taken into account in calculating the flow resistance. Refer to Sections 3.12, 3.13 and 3.14.
  - c) Have a vertical section of pipe at least 300 mm long, below the tundish before any elbows or bends in the pipe work.
  - d) Be installed with a continuous fall of 1:200 (0.286°).
  - e) Have discharges visible at both the tundish and the final point of discharge but where this is not possible or practically difficult there should be clear visibility at one or other of these locations.
2. Examples of acceptable discharge arrangements are:
  - a) ideally below a fixed grating and above the water seal in a trapped gully.
  - b) downward discharges at a low level; i.e. up to 100mm above external surfaces such as car parks, hard standings, grassed areas etc. are acceptable providing that where children may play or otherwise come in to contact with discharges, a wire cage or similar guard is positioned to prevent contact, whilst maintaining visibility.
  - c) discharges at high level; e.g. into a metal hopper and metal down pipe with the end of the discharge pipe clearly visible (tundish visible or not) or onto a roof capable of withstanding high temperature discharges of water and 3m from any plastics guttering systems that would collect such discharges (tundish visible).
3. Where a single pipe serves a number of discharges, such as in blocks of flats, the number served should be limited to not more than 6 systems so that any installation can be traced reasonably easily.

The single common discharge pipe should be at least one pipe size larger than the largest individual discharge pipe to be connected.

If unvented hot water storage systems are installed where discharges from safety devices may not be apparent i.e. in dwellings occupied by blind, infirm or disabled people, consideration should be given to the installation of an electronically operated device to warn when a discharge takes place.

## ! NOTE !

**The discharge will consist of scalding water and steam. Asphalt, roofing felt and non-metallic rainwater goods may be damaged by such discharges.**

### 3.16 DISCHARGE PIPE SIZING

Refer to Table 3-2 (discharge pipe sizing).

**Table 3-2:** Discharge pipe sizing

Valve outlet size Diameter (inches)	Minimum size of discharge pipe D1 (mm)	Minimum size of discharge pipe D2 from tundish (mm)	Maximum resistance allowed, expressed as a length of straight pipe, i.e. no elbows or bends (m)	Resistance created by each elbow or bend (m)
½	15	22	Up to 9	0.8
		28	Up to 18	1.0
		35	Up to 27	1.4
¾	22	28	Up to 9	1.0
		35	Up to 18	1.4
		42	Up to 27	1.7
1	28	35	Up to 9	1.4
		42	Up to 18	1.7
		54	Up to 27	2.3

## ! NOTE !

**The above table is based on copper tube. Plastic pipes may be of a different bore and resistance.**

**Sizes and maximum lengths of plastic pipe should be calculated using data for the type of pipe being used.**

### 3.17 WORKED EXAMPLE

The example below is for a ½" diameter temperature relief valve with a discharge pipe (D2) having 4 x 22mm elbows and a length of 7m from the tundish to the point of discharge.

From Table 3-2:

Maximum resistance allowed for a straight length of 22mm copper discharge pipe (D2) from a ½" diameter temperature relief valve is 9.0m.

Subtract the resistance for quantity of 4 x 22mm elbows at 0.8m each = 3.2m.

Therefore, the maximum permitted length is 9.0 - 3.2 = 5.8m.

5.8m is less than the actual length of 7m; therefore calculate the next largest size.

Maximum resistance allowed for a straight length of 28mm copper discharge pipe (D2) from a ½" diameter temperature relief valve is 18m.

Subtract the resistance for a quantity of 4 x 28mm elbows at 1.0m each = 4m.

Therefore, the maximum permitted length is 18 - 4 = 14m.

As the actual length is 7m, a 28mm diameter copper pipe will be satisfactory in this case.

### 3.18 DISCHARGE PIPE ARRANGEMENT

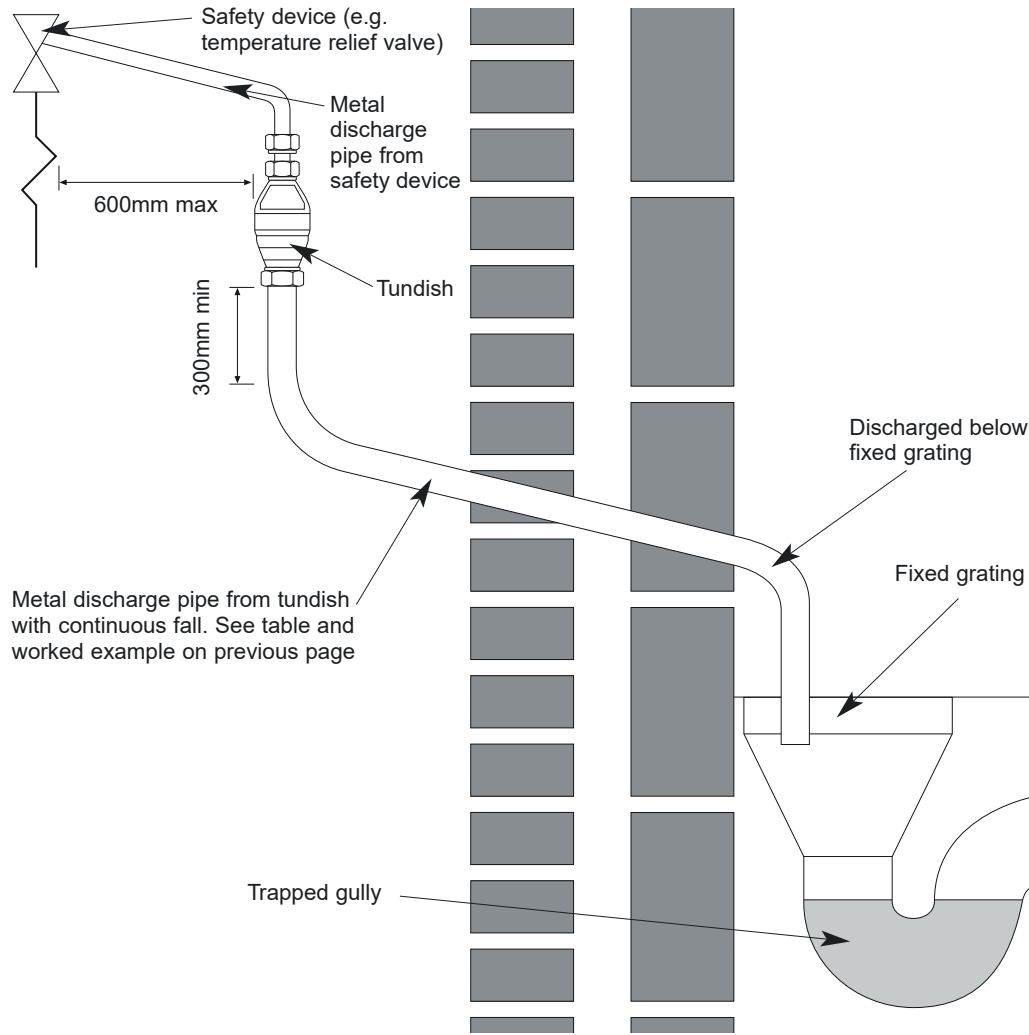

Figure 3-5: Typical discharge pipe arrangement

### 3.19 HOSE KITS

Grant UK offer two types of hose kit for primary circuit connection in only Aerona 290 installations.

- **HPHOSEKIT** - This kit comes with 2 x uninsulated flexi hoses and 2 x 28mm ball valves.
- **HPHOSEKITPRO** - This kit comes with 2 flexi hoses pre-fitted with primary pro insulation and 2 x 28mm long stem ball valves and sealant.

For Grant Aerona<sup>3</sup> installations the flexi hoses and isolation valves are supplied with the Aerona Smart Controller kit.

### 3.20 PUMP OVER-RUN PROTECTION

The Grant Aerona Smart controller works in conjunction with the Aerona heat pump to ensure there is no dead heading of the circulating pump at the end of:

- Space Heating & DHW demands
- Defrost cycles
- Frost protection cycles

When any of the above functions end and no other demands are to run, the circulating pump will complete any overrun protection built into the heat pump before going into stand-by. (Refer to supplied installation instructions for the heat pump in question for further details)

To accommodate the flow during this time, the Smart Controller will open any configured space heating valves until the circulating pump stops, after which the valves will be closed.

### 3.21 LEGIONELLA PROTECTION

The Grant Aerona 290 range of heat pumps offer a higher output flow temperature (similar to a conventional Gas or Oil boiler) and can achieve the temperatures required to heat the DHW cylinder sufficiently to protect against Legionella bacteria without the need for additional support from electric immersion heaters when compared to the Aerona<sup>3</sup>.

If required, a Grant Smart Immersion relay can be installed to assist the Grant Aerona 290. Refer to Appendix D for further information.

For Grant Aerona<sup>3</sup> installations, refer to Appendix G for further details.

For information on enabling and configuring Legionella protection, refer to Section 7.4.

### 3.22 AUTOMATIC BYPASS

The Grant Smart controller has a pump overrun protection function that will automatically open the motorised valve(s) to the heating circuit(s) to avoid deadheading the heat pump circulator during the overrun period following space heating demands (including Defrost and Anti-freeze protection routines) and thus does not require an automatic system bypass to be fitted.

However, some systems will still require an automatic system bypass to be fitted, where the heating system has high resistance circuits or where circuits cannot always allow flow when the pump over-run protection is active, such as:

- Underfloor heating installation where the loops are fitted with actuators/valves.
- Underfloor heating installations with direct flow/return manifold connections rather than a 'close coupled T' connection that gives hydraulic separation.
- Where all radiators are fitted with TRVs and there is no radiator fitted with two lockshield valves i.e. always open.

3.22 HYDRAULIC CONNECTIONS - AERONA<sup>3</sup>  
Grant UK Drawing Number: HPCS-T001QR2SR32

Item	Description
1	Aerona <sup>3</sup> ASHP
2	Flexible hose & isolation valves <sup>1</sup>
3	Isolation valve
4	Grant External Volumiser <sup>***</sup> (optional)
5	Anti-Vibration Mounts <sup>2</sup>
6	Flow sensor <sup>1</sup>
7	Grant Mag One magnetic filter kit <sup>2</sup>
8	Wiring Centre Smart Controls <sup>3</sup>
9	Touch Screen Display <sup>2</sup> (Supplied attached to cylinder)
10	Room thermostat (optional)
11	Motorized 2-Port valve (DHW) <sup>2</sup>
12	Cylinder immersion heater <sup>2</sup>
13	Pre-plumbed DHW cylinder
14	Removable filling loop <sup>2</sup>
15	Double check valve <sup>2</sup>
16	Pressure gauge <sup>2</sup>
17	Expansion vessel <sup>2</sup>
18	Tundish <sup>2</sup>
19	Cold water inlet combination valve <sup>2</sup>
20	Thermostatic Radiator valve
21	Motorized 2-Port valve (Radiator circuit) <sup>2</sup>
22	Motorized 2-Port valve (UFH circuit) <sup>2</sup>
23	Thermostatic mixing valve
24	UFH pump. Optional depending on system design)
25	UFH manifold
26	Water Temperature Sensor <sup>1</sup> - Optional
27	Outdoor Weather Sensor <sup>1</sup>
28	Manual air vent <sup>2</sup>
29	Cylinder temperature sensor <sup>2</sup>
30	Pressure relief valve <sup>2</sup>
31	Tundish <sup>2</sup>
32	Pressure relief valve <sup>2</sup>
33	Automatic Bypass - Optional <sup>**</sup>

<sup>1</sup>Supplied with the HP32SMART<sup>2</sup> PP Smart Controller Kit  
<sup>2</sup>Separate kits Available for 6, 10, 13/17 kW outputs  
<sup>3</sup>Supplied with the HPIDPACKP  
<sup>\*</sup>Supplied factory fitted to Pre-Plumbed cylinder  
<sup>\*\*</sup> Refer to installation manual for further details.

**IMPORTANT**  
For positions of the Flow (outlet) and Return (inlet) connections on HPID10R32BODY, HPID13R32BODY and HPID17R32BODY models, see above.

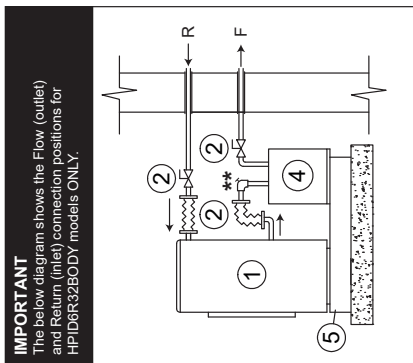

**\*\***Compression elbow c/w air vent (supplied with HPIDVOL50EXT16)

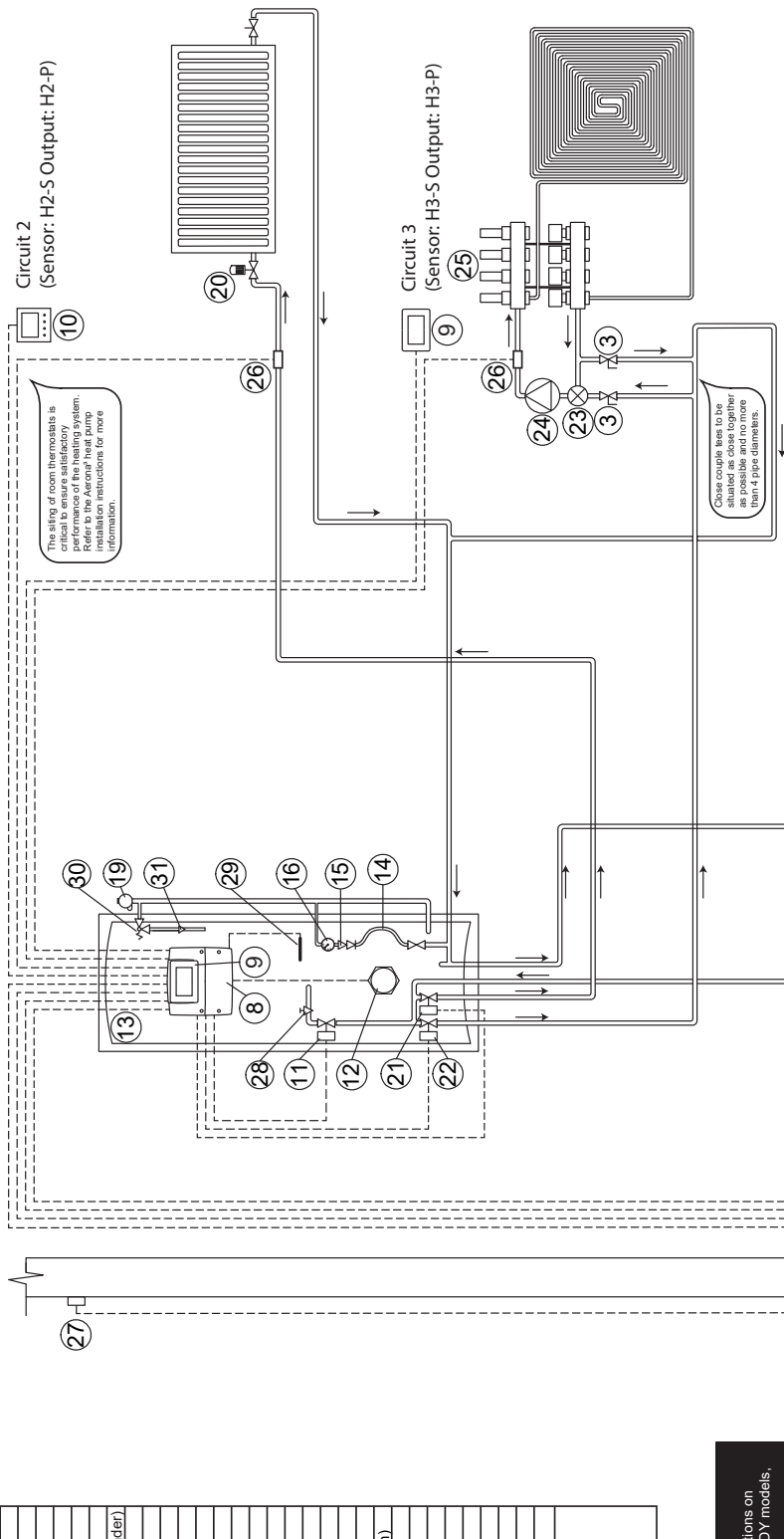

Circuit 2  
(Sensor: H2-S Output: H2-P)

Circuit 3  
(Sensor: H3-S Output: H3-P)

The siting of room thermostats is critical to ensure satisfactory performance of the heating system. Refer to the Aerona<sup>3</sup> heat pump installation instructions for more information.

Close couple leads to the Smart Controller wiring centre as far as possible and no more than 4 pipe diameters.

**Concept Drawing - T001QR2S- Plan**

**DHW Priority**  
DHW 2-port motorised valve (11) will open to allow flow to the DHW circuit on a call for heat. The 2-port motorised valve (21) & (22) will be stopped by the Smart Controller wiring centre closing the valves.

**Circuit 1 - Radiators**  
Circuit demand controlled via thermostat (touchscreen or optional wired/wireless). Circuit 2 port motorised valve (21) operation is managed by the Smart controller using THERMOSTATIC PUMP-BLOCKADE function.

**Circuit 2 - UFH**  
Circuit demand controlled via thermostat (touchscreen or optional wired/wireless). 2 port motorised valve (22) and circulating pump (24) operation is managed by the Smart controller using THERMOSTATIC PUMP-BLOCKADE function. Flow temperature into UFH manifold (25) is managed via thermostatic mixing valve (23) in case Circuit 1 flow temperature is too high for UFH. No actuators fitted on UFH manifold.

**! NOTE !**  
\*\*\*  
50L external volumiser, 50L Internal Volumiser or Low Loss header are available as an optional component where there is insufficient hydraulic separation is required. (HPIDVOL50HPIDVOL50/HPIDSYLLHKIT)

**! NOTE !**  
This system schematic should be read in conjunction with the Grant Aerona<sup>3</sup> Smart Control installation instructions and wiring diagram HPCS-T001ER32.

**! NOTE !**  
For supplementary heater support from a Low Loss Header, Refer to DOC0217 - QR2 Smart Pre plumbed Cylinder manual and related product manuals. Visit [www.grantuk.com](http://www.grantuk.com) for further information

**! NOTE !**  
Please refer to the Aerona<sup>3</sup> ASHP installation instructions for details of the flow and return connections at the heat pump.

3.23 HYDRAULIC CONNECTIONS - AERONA 290  
Grant UK Drawing Number: HPCS-T001QR2SR290

Item	Description
1	Aerona 290 ASHP
2	Flexible hose & Isolation valves*
3	Isolation valve
4	Grant Internal Volumiser*** (optional)
5	Anti-Vibration Mounts <sup>2</sup>
6	Grant Mag. One magnetic filler kit <sup>2</sup>
7	Wiring Centre Smart Controls <sup>3</sup>
8	Touch Screen Display <sup>3</sup> (Supplied attached to cylinder)
9	Room thermostat
10	Motorized 2-Port valve (DHW) <sup>3</sup>
11	Cylinder immersion heater <sup>2</sup>
12	Cylinder temperature sensor <sup>2</sup>
13	Pre-Plumbed DHW cylinder
14	Removable filling loop <sup>3</sup>
15	Double check valve <sup>3</sup>
16	Pressure gauge <sup>2</sup>
17	Expansion vessel <sup>2</sup>
18	Tundish <sup>1</sup>
19	Cold Water Inlet combination valve <sup>3</sup>
20	Thermostatic Radiator valve
21	Motorized 2-Port valve (Radiator circuit) <sup>3</sup>
22	Motorized 2-Port valve (UFH circuit) <sup>3</sup>
23	Thermostatic mixing valve
24	UFH pump (Optional depending on system design)
25	UFH manifold
26	Water Temperature Sensor <sup>1</sup> - Optional
27	Outdoor Weather Sensor <sup>1</sup>
28	Manual air vent <sup>2</sup>
29	Pressure relief valve <sup>2</sup>
30	Pressure relief valve <sup>2</sup>
31	Tundish <sup>1</sup>
32	Automatic Bypass - Optional <sup>1</sup>

<sup>1</sup> Supplied with the HP290SMARTPP Smart Controller Kit  
<sup>2</sup> Supplied with the HPIDPACKP  
<sup>3</sup> Supplied factory fitted to Pre-Plumbed cylinder  
<sup>4</sup> Available hose kits: HPHOSEKIT or HPHOSEKITPRO  
<sup>5</sup> Refer to installation manuals for further details.

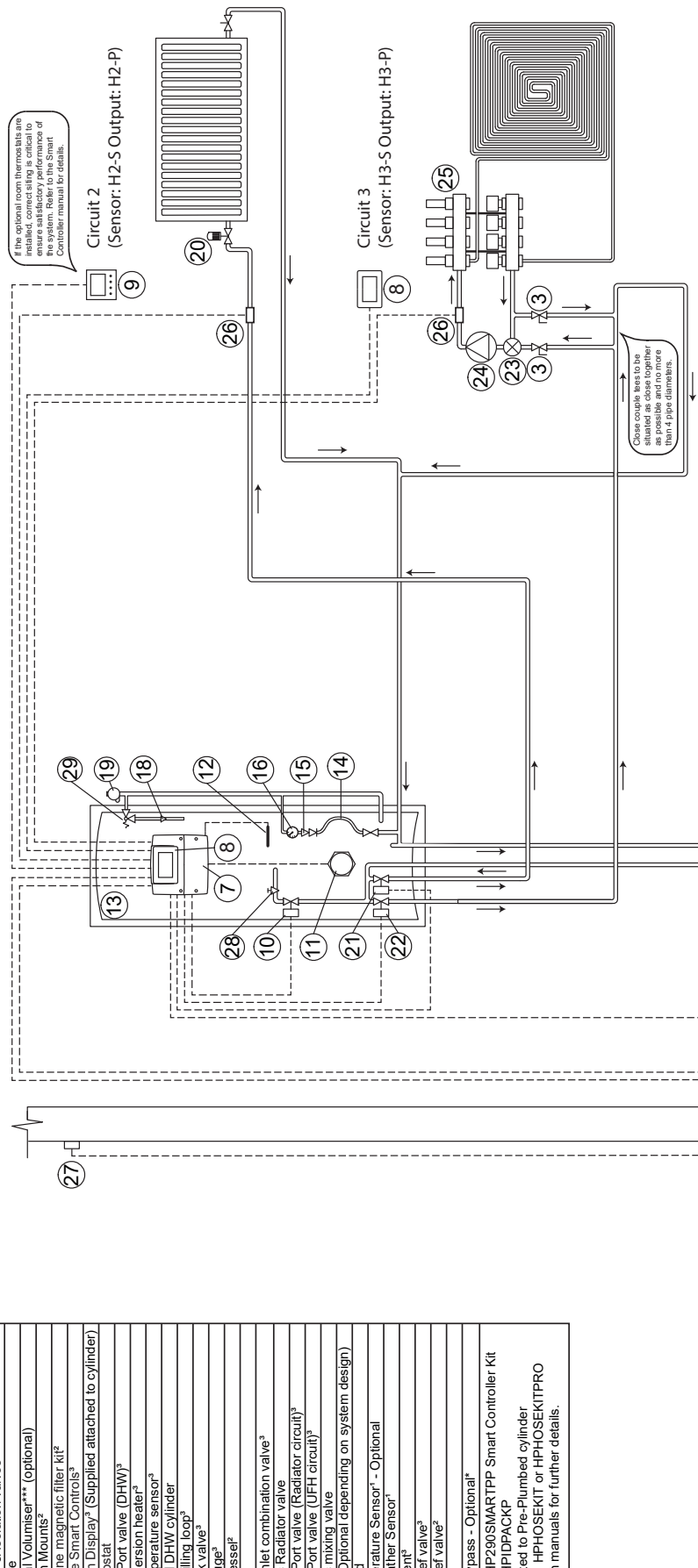

**Concept Drawing - T001QR2S- Plan**

**DHW Priority**  
 DHW 2-port motorised valve (10) will open to allow flow to the DHW circuit on the Smart Controller using THERMOSTATIC PUMP BLOCKADE function. (21) & (22) will be stopped by the Smart Controller wiring centre closing the valves.

**Circuit 1 - Radiators**  
 Circuit demand controlled via thermostat (touchscreen or optional wired/wireless). Circuit 2 port motorised valve (22) and circulating pump (24) operation is managed by the Smart controller using THERMOSTATIC PUMP BLOCKADE function.

**Circuit 2 - UFH**  
 Circuit demand controlled via thermostat (touchscreen or optional wired/wireless). 2 port motorised valve (22) and circulating pump (24) operation is managed by the Smart controller using THERMOSTATIC PUMP BLOCKADE function. Flow temperature into UFH manifold (25) is managed via thermostatic mixing valve (23) in case Circuit 1 flow temperature is too high for UFH. No actuators fitted on UFH manifold.

**! NOTE !**

For supplementary heater support from a Low Loss Header. Refer to DOC0217 - QR2 Smart Pre plumbed Cylinder manual and related product manuals. Visit [www.grantuk.com](http://www.grantuk.com) for further information

**! NOTE !**

This system schematic should be read in conjunction with the Grant Aerona Smart Control Installation instructions and wiring diagram HPCS-T001QR290.

**! NOTE !**

\*\*\*50L Internal volumiser is available as an optional component where there is insufficient system volume (HPIDVOL.50). Refer to DOC 0207 - Grant Internal 50L Volumiser for further information.

**! NOTE !**

Please refer to the Aerona 290 ASHP installation instructions for details of the flow and return connections at the heat pump.

# 4 ELECTRICAL

All electrical wiring must be carried out by a competent person and in accordance with the current edition of BS7671 (the I.E.T. Wiring Regulations), including any amendments.

The control equipment supplied must be wired according to these Installation and User Instructions to ensure that the cylinder functions safely.

From an economic and convenience point of view, it is intended that these controls operate in conjunction with other control packages, for example, an "S-plan" type system that incorporates a programmer, etc.

## 4.1 MAINS CONNECTION

Grant QR2 Smart pre-plumbed cylinders will require a single 20A mains supply to service both the Smart controller and 3kW immersion heater (both factory-fitted). The mains connection point is accessed via the hinged panel of the electrical housing which has the touchscreen display mounted on to it.

The mains supply should be:

- inserted into the top of the cylinder electrical housing through the hole supplied.
- be sufficiently stripped back and connected to the correct live neutral and earth connectors.
- securely fixed in place with interior cable clamp to avoid stress on the mains cable.

To access, unscrew the 2 screws at the top of the electrical housing to allow the panel to hinge open.

The incoming mains supply is fused down using 2 factory-fitted B rated MCB (16A for the Immersion heater and 6A for the Smart Controller). Refer to Figure 4-10 for factory-fitted connections and wiring representation for connecting the mains.

## 4.2 IMMERSION HEATER

All Grant QR2 indirect Heat Pump cylinders are supplied factory-fitted with one 3kW immersion heater. This immersion heater conforms to:

- EN 60730-1:2016/A1:2019
- EN IEC 60730-2-9:2019
- EN IEC 60730-2-9:2019/A1:2019
- EN IEC 60730-2-9:2019/A2:2020
- EN 60730-1:2016
- Intertek BEAB Mark:
- EN60335-1:2012, A11, A13, A1, A2, A14, A15
- EN60335-2-73:2003+A1, A2, A11

The control thermostat is pre-set on position "4.5" at a temperature of approximately 61.5°C(±3°C). Refer to Figure 4-2.

Installation and wiring instructions for the immersion heater are supplied with each unit. The wiring connections are also shown in Figure 4-1. Follow the wiring instructions connecting the live, neutral and earth as indicated.

The immersion heater must be permanently connected to the electrical supply via the immersion heater relay (factory-fitted) which incorporates a double-pole isolator and is fused at 16 amps. Refer to Sections 7.4, 7.16 and Appendix D for further information on utilising the immersion heater with the factory-fitted Smart Controller and Figures 4-2 and 4-3 for connection details. A safety cut-out is also incorporated within the thermostat and is factory set to operate at 83°C(±5°C).

The immersion heater is factory-fitted to the cylinder. If the immersion heater needs to be replaced it must be fitted to the cylinder using the gasket provided on the unit. Only use a correctly shaped spanner. Stilsons or pipe grips should not be used. The use of sealing compound is not recommended.

## ! WARNING !

**The immersion heater must NOT be used unless it is fully immersed in water.**

**Always ensure that the cylinder is full of water BEFORE switching on the electrical supply.**

Refer to Figure 2-2 for the position of the immersion heater.

## 4.3 IMMERSION HEATER WIRING INSTRUCTIONS

Ensure that the supply voltage corresponds to the voltage rating of the immersion heater as shown on the rating label on the terminal cover.

Each 3kW 230V 50Hz-immersion heater should be wired in accordance with the instructions given in Figure 4-1.

The cable must be routed through the strain relief bush. The cable grip should be secured using only the screws provided.

The 230V 50Hz power supply for the immersion heater should be wired to the 20A mounted relay (factory-fitted), which incorporates a double pole isolator switch and is independently fused at 16 amps.

The 20A relay switch is wired to the Smart Controller wiring centre (factory-fitted) for anti-Legionella protection Refer to Section 7.4 for further information on configuring anti-Legionella protection with the Grant Smart Controller and Figures 4-2 for connection details..

The installer should use a suitable sized, heat resistant cable for final connection to the immersion heater. 3183TQ or 3093Y are the most common ones and are both rated to 90°C, and 1.5mm<sup>2</sup> is suitable for up to 16A. The immersion heater must be earthed.

## ! WARNING !

**Always ensure that the immersion heater cap is not covered.**

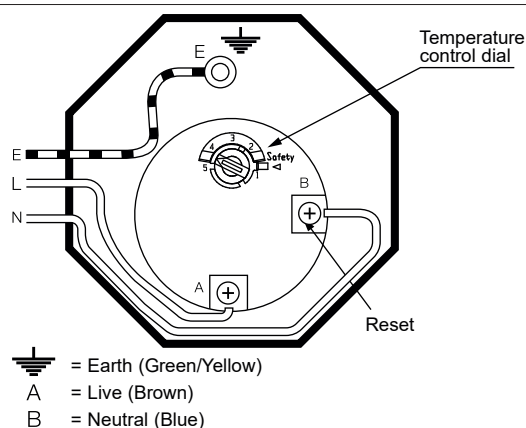

Figure 4-1: Immersion heater wiring connections

## ! WARNING !

**This immersion heater must be earthed.**

## ! WARNING !

**The manual reset high limit thermostat must not under any circumstances be by-passed. This is pre-set to 70°C (±5°C) and to prevent nuisance tripping, the control thermostat should always be left in the 4.5 position. (For temperature of approximately 61.5°C(±3°C). Refer to Figure 4.2**

#### 4.4 IMMERSION HEATER SAFETY CUT-OUT

The immersion heater incorporates an independent non self-resetting over temperature cut-out device to prevent excessive water temperatures.

In normal operation the reset pin positioned to the side of the control knob and indicated by a triangle (with the words 'safety' above) will be approximately 2-3mm below the upper surface of the thermostat cap. Refer to Figure 4-2.

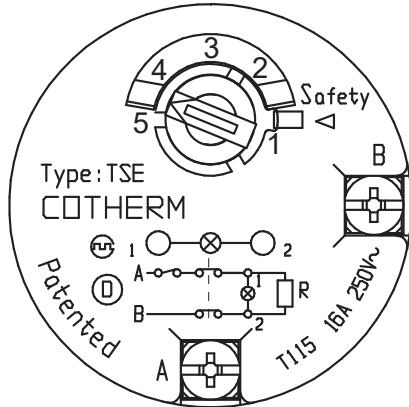

Figure 4-2: TSE single pole thermostat plan view details

Should the over temperature cut-out operate:

- The reset pin will be pushed upwards to become level with or slightly above the cover.
- Wait until the temperature has fallen sufficiently.
- Investigate and identify the cause of the cut-out operation and rectify the fault.

Manually reset the cut-out by pressing in the reset pin to its normal operating position using hand pressure only with a suitably sized implement.

### ! WARNING !

**Before removing the immersion heater covers to either reset the safety cut-out or check/alter the thermostat setting, ensure that the electrical supply is isolated.**

Ensure the cover to the immersion heater cover is replaced correctly and the retaining nut is fitted. Finally switch the mains electricity supply back on.

#### 4.5 HIGH LIMIT THERMOSTAT

A non self-resetting high limit thermostat is supplied factory-fitted to the Grant QR2 Smart pre-plumbed cylinder to control the operation of the heat pump primary coil. Refer to Figure 2-2 for position.

The high limit (overheat) thermostat will automatically operate at 90°C and disable the DHW 2-port zone valve to prevent further heated water from entering the cylinder.

For details on wiring connections, refer to Figures 4-3.

#### 4.6 2-PORT VALVES

To comply with the regulations governing the installation of indirect unvented hot water cylinders, a 2-port motorised valve is fitted in the primary flow to prevent gravity circulation when the heat pump switches off.

This acts as a positive energy cut-out should the high limit (overheat) thermostat operate. If this happens, the 2-port zone valve will operate and shut off the primary flow to the cylinder.

When installed as part of an "S-plan" type of heating control system, this motorised valve will also control the temperature of the domestic stored water via the factory-fitted water temperature sensor connected to the controller.

This valve is supplied fitted to the cylinder. Refer to Figure 2-2 for position. It is wired in accordance with Figure 4-4 to comply with current legislation.

#### 4.7 IMMERSION OVERRIDE

The Grant QR2 Smart pre-plumbed cylinder is factory fitted with an immersion override switch to provide the homeowner with the ability to manually activate the factory-fitted 3kW immersion heater should there be an issue with the smart controller.

The immersion override will energise the 3kW immersion heater to heat to the temperature set on the element (Refer to Section 4.2 to 4.4). This is not managed via the Smart controller circuit settings.

All required safety devices (as part of the unvented hot water system requirements) must be present to manage excessive heating of water in this sealed cylinder.

### ! WARNING !

**If water is seen to flow from either the Temperature & Pressure Relief (T&P Valve) valve or the Expansion Relief Valve (EV) on the cylinder, seek expert advice immediately.**

**If the water is flowing from the T&P Valve, immediately:**

1. Shut off the electrical supply to the immersion heater(s).
2. Shut down the boiler or other heat sources to the cylinder e.g. solar, heat pump, etc.
3. **DO NOT SHUT OFF THE WATER SUPPLY TO THE CYLINDER.**
4. Contact your installer to check the system

**Do NOT tamper with any of the Safety controls fitted to the cylinder. If you suspect a fault always contact a competent installer who is qualified to work on unvented water cylinders.**

The immersion override should not be used to reheat the cylinder, should a period of unexpected increased demand require so.

This can be achieved using 'BOOST' on the DHW circuit controls of the Smart controller. Refer to Section 7.3.2.2 for further information.

#### 4.8 SMART CONTROLLER WIRING CENTRE

The Smart Controller wiring centre is supplied factory-fitted to Grant QR2 Smart pre-plumbed indirect heat pump cylinders and is wired as shown in Figure 4-3.

The Grant Smart Controller has been designed as a simple and convenient means of making all system control connections for up to three space heating zones, plus one hot water zone, in one wiring centre, with optional capability to provide both volt free inputs and automatic DHW priority (for Grant Aerona heat pump installations).

The Grant Aerona Smart controller provides a simple to navigate touch screen experience for the user to schedule 7 day space heating & DHW demands, weather compensation of flow temperatures based on outdoor temperatures and remote monitoring and control via the supplied Wi-Fi hub.

#### 4.9 CABLE MANAGEMENT

The wiring centre is manufactured with a series of cut outs to both sides of the housing for easy cable management. Refer to Figure 4-2.

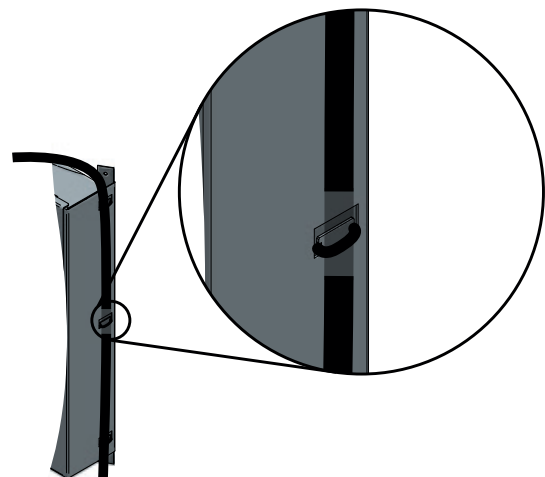
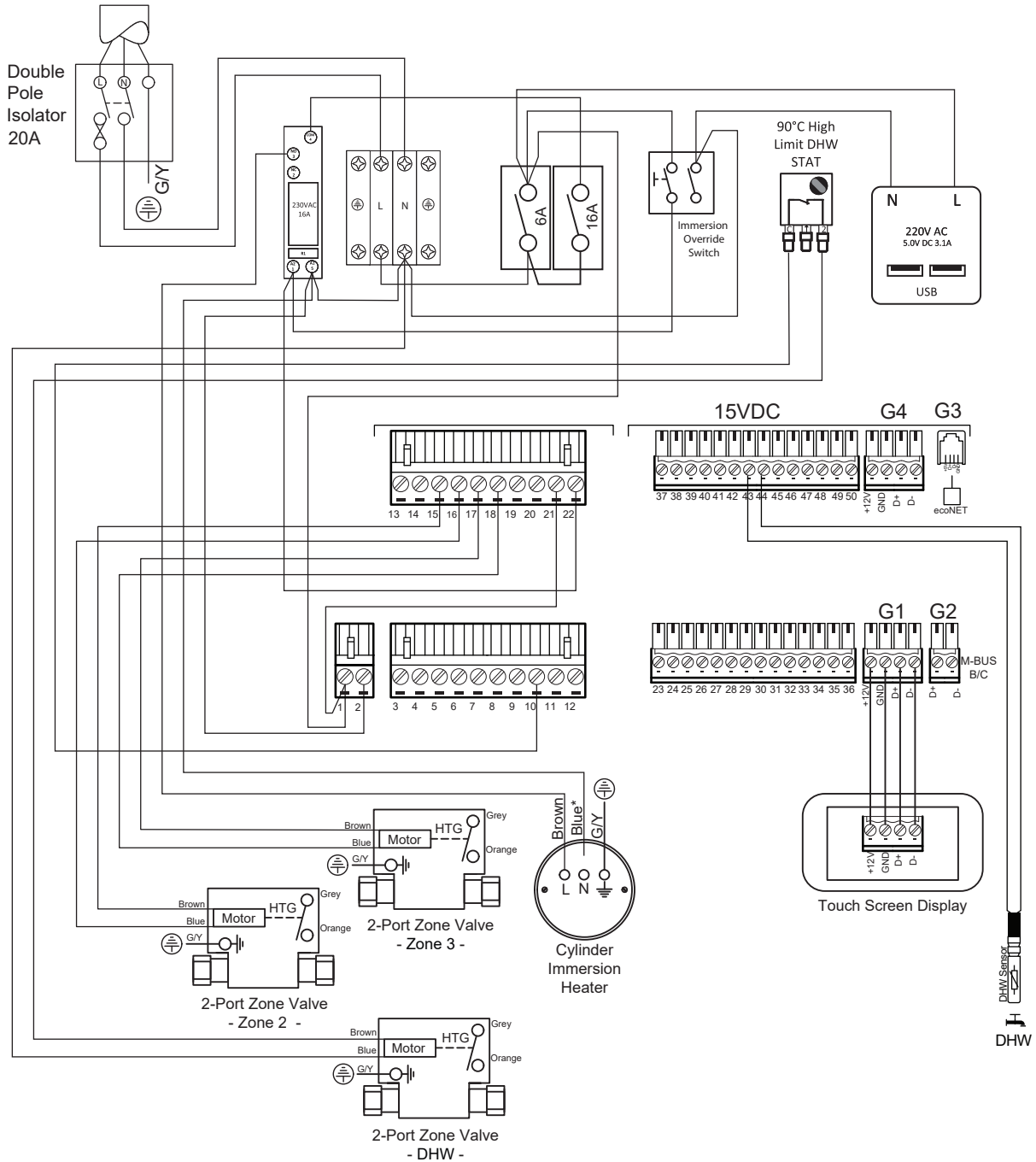

Figure 4-3: Cable management

### 4.10 FACTORY-FITTED CONTROLLER- WIRING DIAGRAM

The wiring diagram shown below demonstrates how the electrical components supplied with the Grant QR2 Smart pre-plumbed indirect heat pump cylinder are wired from the factory.



**Figure 4-4:** Grant QR2 Smart pre-plumbed indirect heat pump cylinder wiring diagram

### 4.11 COMPONENT CONNECTIONS

Electrical components of the planned system are to be connected to the wiring centre of the Grant Aerona smart controller. Refer to Section 4.14 for wiring centre layout.

With the adjustable circuits, mixing needs a water temperature sensor connected to monitor the mixed water entering the circuit to adjust accordingly. Table 4-1 displays the relation between the individual heating circuit and its associated component terminals.

The factory-fitted space heating 2-port zone valves are pre-wired for use with Circuits 1 & 2 (H1-P and H2-P).

**Table 4-1:** Circuit component connections

Heating Circuit	Pump/Valve	Mixer	Water sensor
1	H1-P	None	None
2	H2-P	H2-M	H2-S
3	H3-P	H3-M	H3-S

Motorised rotary actuator valves can be attached if required.

### 4.12 POWER SUPPLY FAILURE

In case of power supply failure, the controller returns to the work mode in which it was working previously when the power supply is restored.

### 4.13 SWITCH RELAYS

The Aerona Smart controller contains a number of switch relays for remote activation of various components. Any utilised switch relays must be externally protected with an adequate fuse. Refer to Table 4-2

### 4.14 WIRING CENTRE LAYOUT

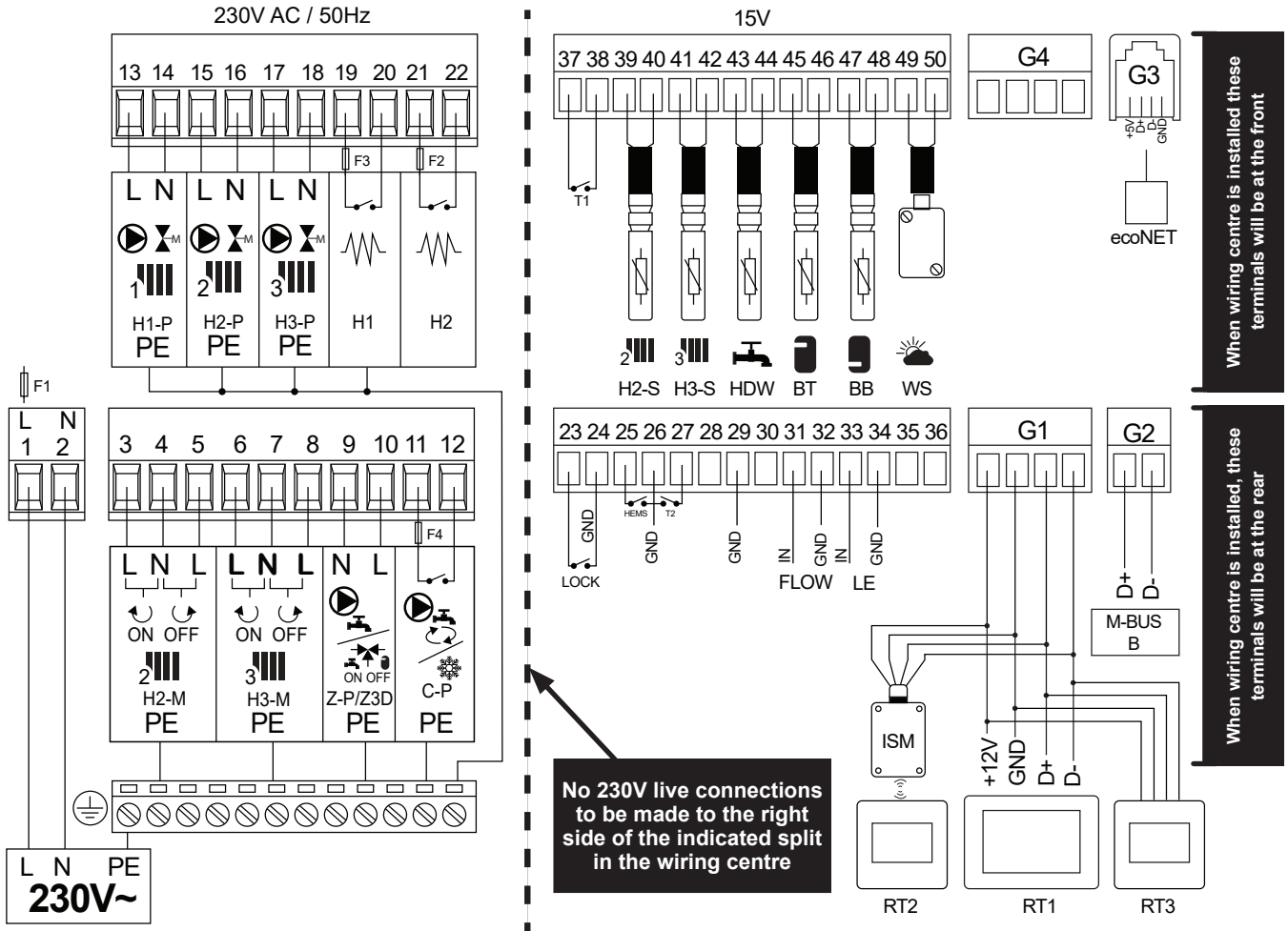

Figure 4-5: Wiring centre - Terminals

Table 4-2: Wiring Centre Terminals

Label	Terminal Numbers	Description
230V ~	1 & 2	Mains Live and Neutral
H2-M	3, 4 & 5	Circuit 2 Mixing valve - 2 x 230V Lives (ON and OFF) and Neutral
H3-M	6, 7 & 8	Circuit 3 Mixing Valve - 2 x 230V Lives (ON and OFF) and Neutral
Z-P/Z3D	9 & 10	DHW Pump/3-Port Diverter Valve
C-P	11 & 12	Secondary Circulation Switched Relay (must be Externally fused 'F4')
Flow	31 & 32	Flow sensor I/O & Ground
LE	33 & 34	Electricity Meter or EvoLink Smart PWM feedback (when AHS enabled)
G1	Terminal Set	Touchscreen & Thermostat connection terminals (RT1, RT2, RT3)
G2	M-BUS	Modbus connection to the Aeraona Heat pump.
G3	G3 Socket	Connection port for ecoNET cable
G4	Terminal Set	+12V, Ground, D+, D-
H1-P	13 & 14	Circuit 1 230V Switched Live and Neutral
H2-P	15 & 16	Circuit 2 230V Switched Live and Neutral
H3-P	17 & 18	Circuit 3 230V Switched Live and Neutral
H1	19 & 20	Switch for Immersion Relay (Back-up heater - must be Externally fused 'F3')
H2	21 & 22	Switch for Immersion Relay (DHW Cylinder - must be Externally fused 'F2')
H2-S	39 & 40	Circuit 2 Water temperature sensor
H3-S	41 & 42	Circuit 3 Water temperature sensor
HDW	43 & 44	DHW Cylinder Water temperature sensor
BT	45 & 46	Buffer Upper Water temperature sensor for Circuit 1 or Boiler Flow sensor (when AHS enabled)
BB	47 & 48	Buffer Lower/Low Loss Header temperature sensor
WS	49 & 50	Outdoor Weather sensor
T1	37 & 38	External Volt-free switch or EvoLink flow sensor (when AHS enabled)
T2	26 & 27	External Volt-free switch for Circuit 2 or 3
LOCK	23 & 24	External Volt-free switch for 'Heat Pump lock'. (Refer to Section 8)
HEMS	25 & 26	Not used

**4.15 ELECTRICAL CONNECTIONS - AERONA<sup>3</sup>**  
 Grant UK Drawing Number: HPCS-T001QR2ER32

Notes: Some Neutral and Earth connections have been excluded for clarity.

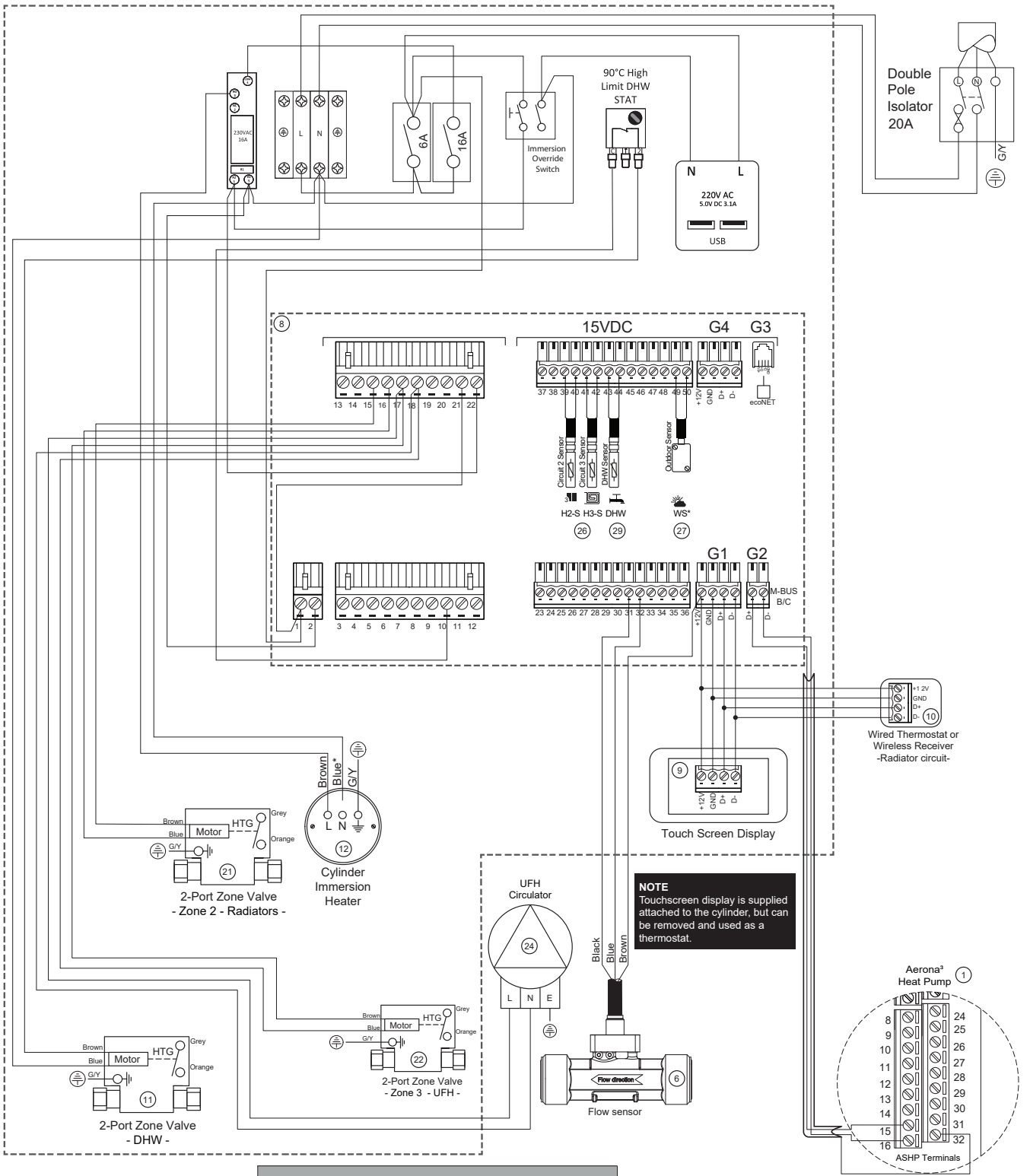

**! NOTE !**

Cable shielding must be connected to the ground at the heat pump only when connecting the modbus cable.

**! NOTE !**

\*Please ensure that neutrals are derived from the same supply to prevent spurious MCB/RCD trips.

**! NOTE !**

This wiring diagram should be read in conjunction with the Grant AERONA Smart Controls installation instructions and system schematic HPCS-T001SR32.

**4.16 ELECTRICAL CONNECTIONS - AERONA 290**  
 Grant UK Drawing Number: HPCS-T001ER290

Notes: Some Neutral and Earth connections have been excluded for clarity.

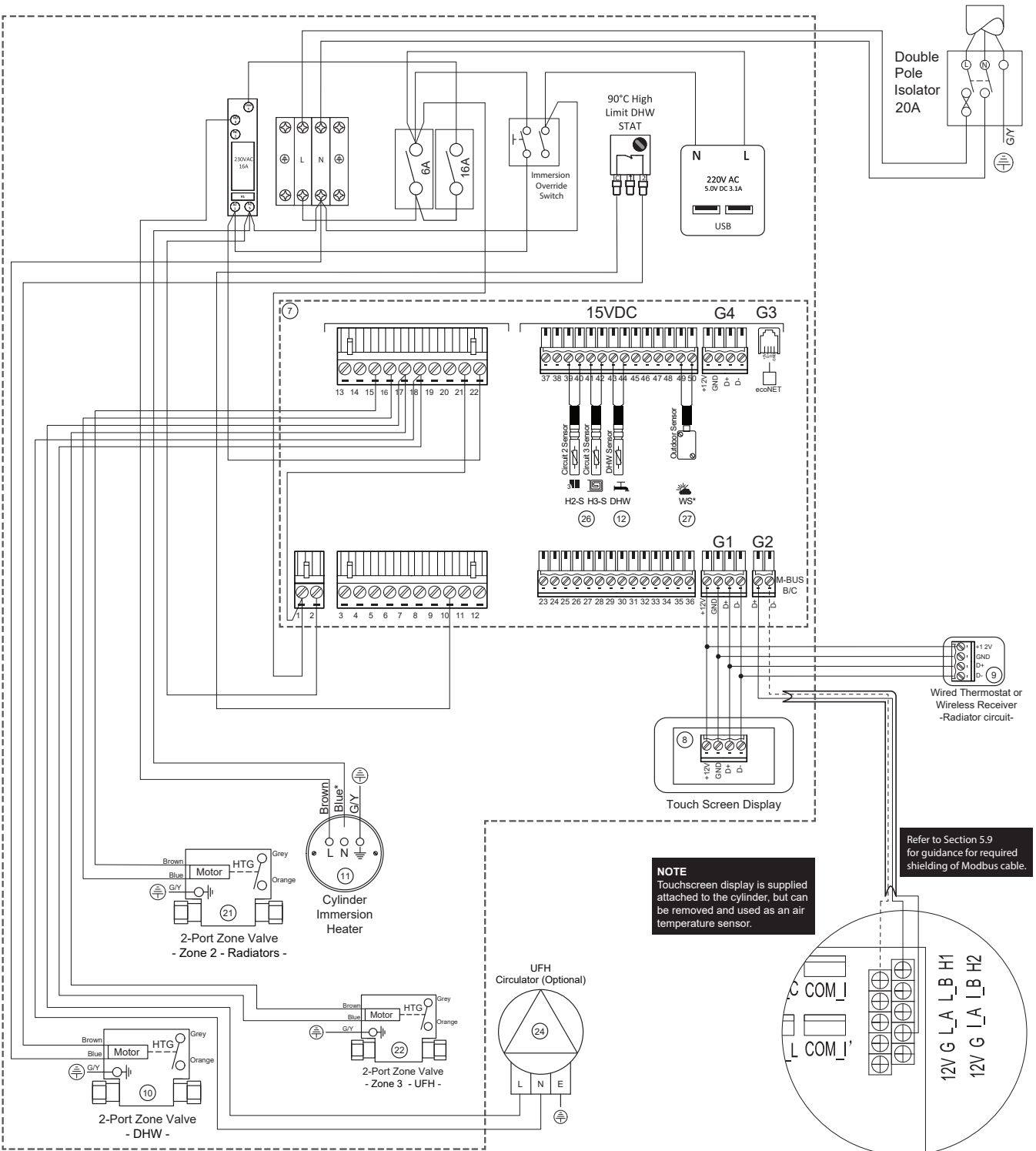

**NOTE**  
 Touchscreen display is supplied attached to the cylinder, but can be removed and used as an air temperature sensor.

Refer to Section 5.9 for guidance for required shielding of Modbus cable.

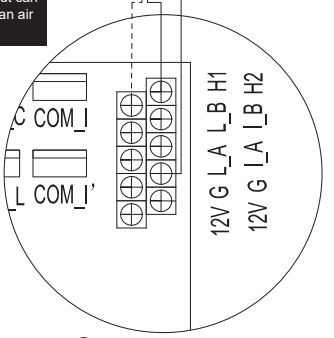

① Grant Aerona 290 Hydraulic PCB

- ! NOTE !**
- Cable shielding must be connected to the ground at the heat pump only when connecting the modbus cable.
- ! NOTE !**
- \*Please ensure that neutrals are derived from the same supply to prevent spurious MCB/RCD trips.
- ! NOTE !**
- This wiring diagram should be read in conjunction with the Grant Aerona Smart Controls installation instructions and system schematic HPCS-T001SR290.

# 5 SMART CONTROLLER

## 5.1 TOUCHSCREEN DISPLAY

The Smart controller touchscreen display is supplied mounted to the Smart cylinder on the front of the electrical housing but in this configuration can not be used as a circuit thermostat. Additional thermostats will be required for the circuit(s) installed.

If required, the touchscreen display can be removed from the Smart cylinder and be wall mounted within the property to be used as a thermostat for a space heating circuit.

### 5.1.1 CYLINDER MOUNTED TOUCHSCREEN

If it is decided to leave the touchscreen on the cylinder, additional thermostats will need to be connected for the circuits installed. Refer to Section 5.7 for wired and wireless thermostat installation.

### 5.1.2 REMOVING THE TOUCHSCREEN DISPLAY

If it is decided to utilise the touchscreen display within the property as a thermostat, you will need to first remove the touchscreen display from the cylinder.

1. Remove the touchscreen display from the mounting plate. The plate is attached to the touchscreen with latches. Use a flat screwdriver to detach the plate. Refer to Figure 5-3.
2. Remove the 4 screws that hold the mounting plate to the electrical housing.

## ! WARNING !

**Ensure the electrical supply is isolated when accessing the Smart controller wiring centre.**

3. Detach the lower section of the Aerona Smart controller wiring centre via the 2 screws and remove the panel. Refer to Figure 5-1.

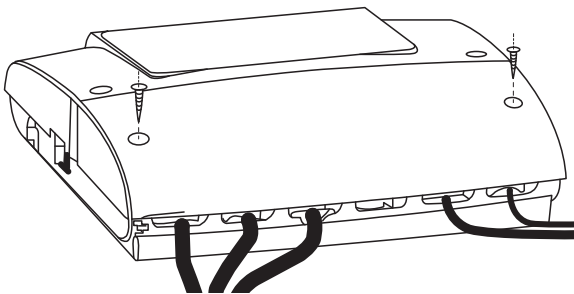

Figure 5-1: Wiring centre cover

4. Loosen the terminal screws for 4 connections of the G1 socket and remove wires. Refer to Section 4.12 for wiring centre layout.
5. Unscrew the terminal screws from each of the connections on the mounting plate.
6. Gently pull the cable from the electrical housing.

### 5.1.3 WALL MOUNTING THE TOUCHSCREEN DISPLAY

If the touchscreen display is being wall mounted and used as a thermostat, it:

- must not be installed in steamy conditions such as a bath or shower room.
- should be mounted at a height allowing comfortable operation, typically 1.5m above the floor.

In addition, to reduce measurement disturbances avoid locations exposed to strong sunlight, with poor air circulation, near heating equipment, and directly at the door and windows, typically 200mm from the edge of the door. Refer to Figure 5-2.

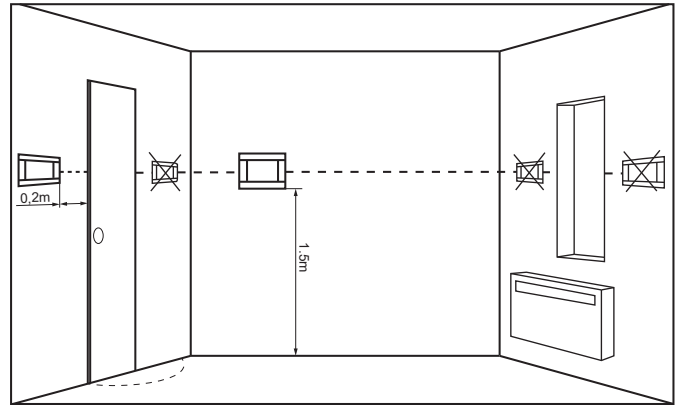

Figure 5-2: Touchscreen display positioning

## ! NOTE !

**When selecting the cable connecting the touchscreen display with the wiring centre, you must use a cable with single wire resistance lower than 8Ω. Total cable length must not exceed 100m.**

The touchscreen display installation should be done according to the following guidelines:

1. Detach the mounting plate from the back of the touchscreen display. The plate is attached to the touchscreen with latches. Use a flat screwdriver to detach the plate. Refer to Figure 5-3.

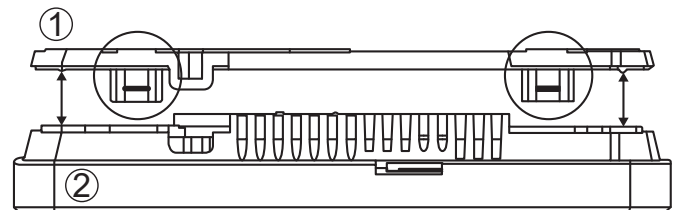

Figure 5-3: Touchscreen display & back plate

2. Connect the cable to the screw terminal as described on the plate. Refer to Figure 5-4. The cable can be recessed in the wall or it can run over its surface - In this case the cable should be additionally placed in the cable channel. Refer to Item 6 in Figure 5-4.

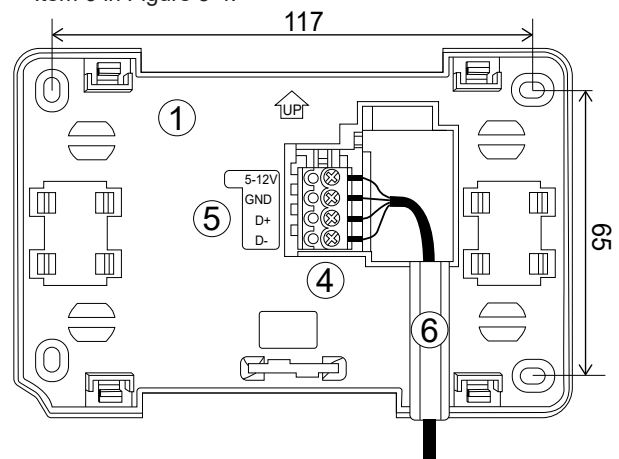

Figure 5-4: Mounting plate wiring

**Table 5-1:** Touchscreen display & mounting plate

No	Description
1	Touchscreen display mounting plate
2	Touchscreen display
3	Mounting plate cut-away
4	Screw terminal
5	Terminal connection guide
6	Cable Channel

- Drill holes in the wall and use screws to fix the mounting plate in position on the wall, observing the correct orientation. (Refer to Figure 5-4).
- Attach the panel to the mounting plate using latches.

## ! NOTE !

**The touchscreen display connection cable can not be ducted with other electrical cables that are part of the building mains and should not be routed near devices that emit a strong Electromagnetic field**

The touchscreen display will need to be re-connected to the wiring centre, fitted to the pre-plumbed cylinder via the G1 socket. Ensure polarities match when connecting the touchscreen display. Refer to Figure 5-7 for touchscreen and thermostat connection.

## ! NOTE !

**The touchscreen display, wireless receiver and any wired thermostats used must only be connected to the G1 socket of the wiring centre.**

### 5.2 TEMPERATURE SENSORS

The Smart Controller should be used only with the Grant supplied Outdoor and Water temperature sensors. At least one Water temperature sensor is necessary to activate the controller and will be required on any mixing circuits utilised.

If not required on space heating circuits, the water temperature sensors can be deactivated from the Smart controller. Refer to 'Section 7.12.2 Circuit Temp. from pump return. This function will cause all active space heating circuits to read the temperature from the return of the heat pump as the active water temperature (Circuits 2 and 3 only).

We recommend the water temperature sensors be fitted as this will provide real-time and historical performance data via the ecoNET platform (if connected).

#### 5.2.1 WATER TEMPERATURE SENSORS

The water temperature sensors should be installed in an area of the system relevant to their function. For heating circuits the most suitable location would be after controlled valves on the circuit flow to give the most accurate reading for the circuit.

Insulate the sensors affixed to the external surface of the pipe using thermal insulation covering the sensor together with the pipe. (Refer to Figure 5-5).

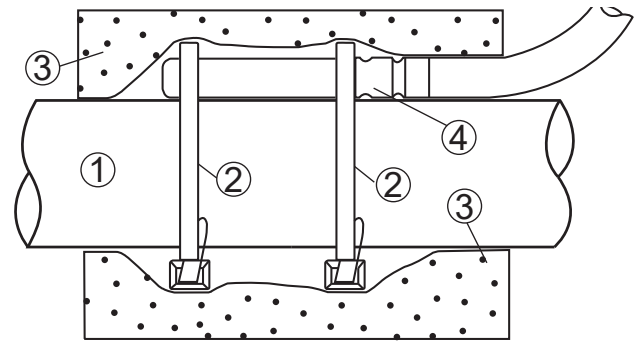
**Figure 5-5:** Circuit temperature sensor fitting**Table 5-2:** Temperature Sensor installation

No	Description
1	Flow Pipe
2	Zip tie
3	Thermal insulation
4	Water Temperature sensor

The Grant QR2 Smart cylinder is supplied with a water temperature sensor factory fitted to monitor the cylinder temperature. Refer to Figure 2-2.

#### 5.2.2 OUTDOOR WEATHER SENSOR

The Outdoor weather sensor is the only external sensor to be used with the Grant Aeron Smart Controller. It should:

- Be fixed to the coldest wall in the building, usually a north wall under the roof.
- Not be exposed to direct sunlight.
- Be fixed between 1.5 and 2m above the ground and in a distance of at least 1.5m from windows, chimneys and other heat sources which could interrupt the temperature measurement.
- Use a connecting cable with a cross section of at least 0.5mm<sup>2</sup> and length of 25m. Polarity of wires is not important.

To fasten the external sensor to the wall.

- Remove the front of the sensor housing. (Refer to Figure 5-6). Position the rear part of the housing against the wall, mark and drill fixing holes.
- Insert the supplied wall plugs, place the housing back into position and secure in place with the screws.

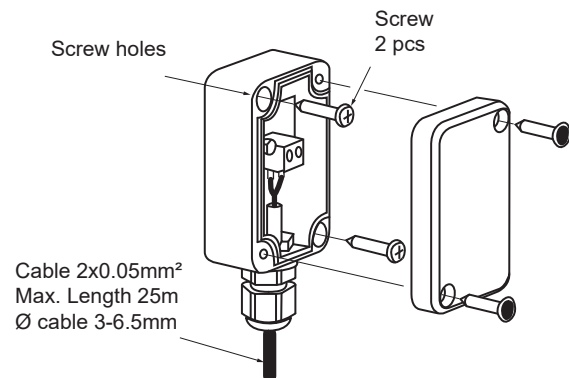
**Figure 5-6:** Outdoor weather sensor

### 5.3 CONNECTING PUMPS

Electrical connections from the circuit pumps to the controller should be according to the electrical schematics. Zones valves for DHW, Circuit 1 and Circuit 2 are factory-fitted and pre-wired. Refer to Section 4.12 for Wiring centre terminals.

## 5.4 CONNECTING 3-PORT MIXING VALVES

The Grant Aerona Smart Controller should only be used with valve actuators equipped with limit switches and the 3-Port mixing valves can only be fitted as part of an adjustable circuit. Refer to Appendix C for further details on 3-Port mixing valves.

A water temperature sensor will also need to be installed after the mixing valve to measure the mixed water flow temperature for the circuit. Refer to Section 4.12 for wiring centre terminals.

## 5.5 CONNECTING RELAYS

Relays for anti-Legionella & supplementary heating from a volumiser, low loss header and a DHW cylinder can be used in conjunction with the Grant Aerona Smart controller.

They are to be connected via H1 (volumiser or low loss header) or H2 (DHW Cylinder) as these terminals are assigned to specific functions within the Smart Controller software. The

The relay for the anti-Legionella protection is factory-fitted with the Grant QR2 Smart pre-plumbed cylinder. Refer to Appendix D for guidance on wiring specifics for supplementary heating.

Refer to Section 7.4 for guidance on configuring anti-Legionella protection.

## 5.6 SMART FLOW SENSOR

The Grant smart flow sensor monitors the return flow rate to the Aerona<sup>3</sup> heat pump to allow calculation of the COP within the Grant Aerona Smart controller. Refer to Appendix E for installation and configuration requirements.

Grant UK recommend the Grant Smart flow sensor be installed internally on the primary circuit return to the heat pump.

If installing externally, ensure to encase to protect the flow sensor from both the elements and external interference.

# ! NOTE !

Ensure to refer to Appendix E.2 for information on correct placement of the flow sensor within the installed system.

The Grant smart flow sensor is not required for Grant Aerona R290 heat pump installations.

## 5.7 ROOM THERMOSTAT CONNECTION

For optimum operation of the Grant Aerona Smart Controller each circuit within the system should have an individual thermostat assigned to it.

The room thermostats connect to the wiring centre via the G1 terminals, and can utilise the weather compensation function to automatically adjust the flow temperature within the circuit to provide a consistent room temperature. The required temperature is set on the room thermostat of the circuit concerned.

It is possible to use the touchscreen as a room thermostat, but must be detached from the Smart cylinder and relocated.

### 5.7.1 WIRED ROOM THERMOSTAT

The Grant Aerona Smart controller can support multiple wired room thermostats (including the touchscreen display). Ensure that the correct polarity of the connections are respected when wiring the room thermostats/touchscreen display in parallel to the wiring centre. (Refer to Figure 5-7).

With the connections made you will need to pair and assign the room thermostats with their own address.

See Appendix A for installation and operation guidance.

# ! CAUTION !

Maximum length of wires should not exceed 30m. This length may be longer if the wires used have cross-section exceeding 0.5 mm<sup>2</sup>.

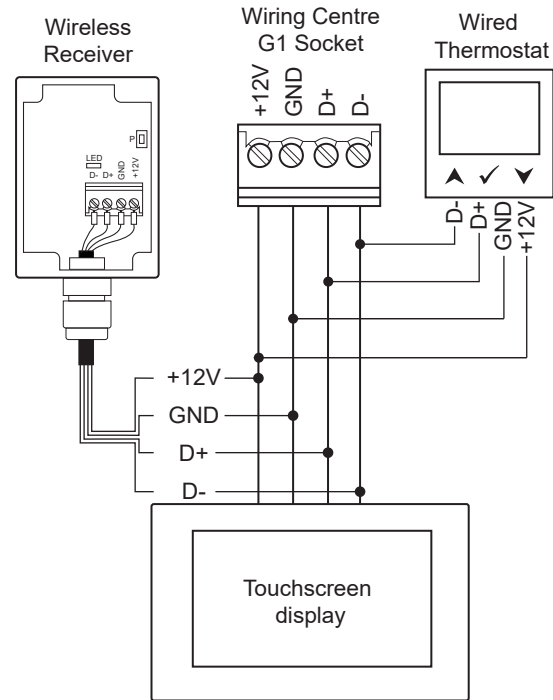

Figure 5-7: Wired and Wireless wiring schematic

### 5.7.2 WIRELESS THERMOSTAT RECEIVER

Connecting a wireless room thermostat requires a wireless receiver to be connected to the G1 socket, in the same fashion as the wired thermostat, and the thermostat(s) paired to the wireless receiver. The wireless receiver can support up to 3 wireless thermostats.

The wireless receiver can be mounted to a wall or to the side of the electrical housing. Use the pre-drilled holes to affix the wireless receiver in place. Refer to Figure 5-8.

See Appendix B for Installation and operation guidance.

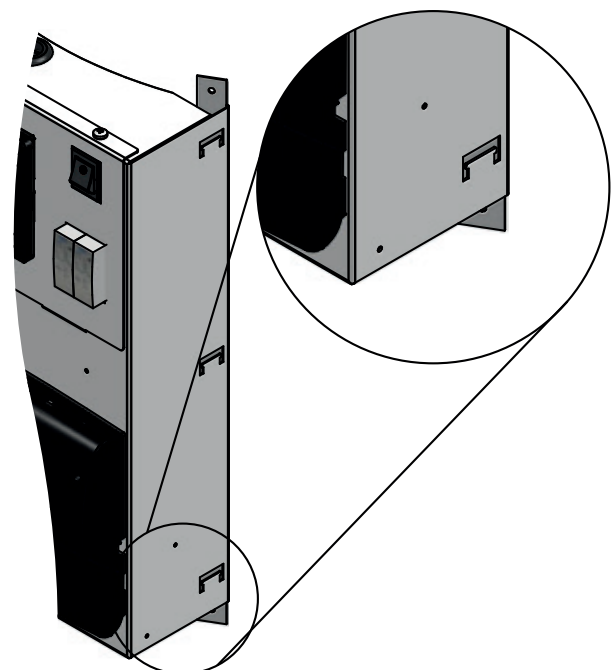

Figure 5-8: Wireless receiver mounting

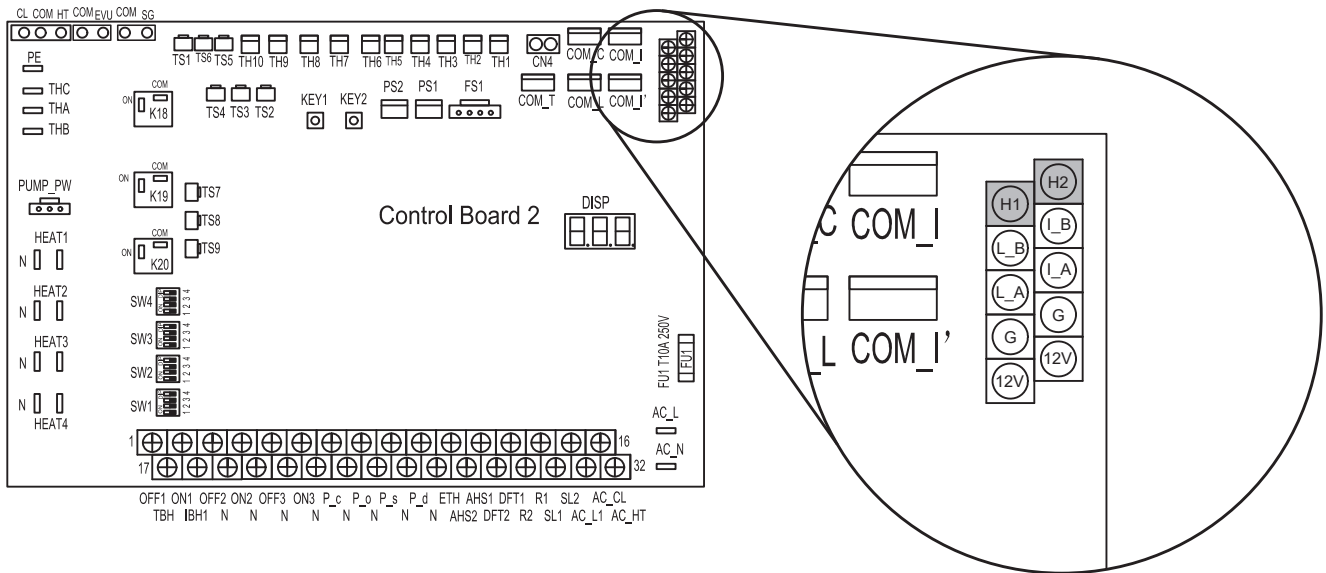

Figure 5-9: Modbus connection to Grant Aerona R290 Heat pump

## ! NOTE !

Close attention must be paid to the 4 connections (+12V, GND, D+ and D-). Ensure they match to corresponding wires from touchscreen display. (+12V is also referenced as VCC).

### 5.8 CONNECTING THE WI-FI HUB

The Wi-Fi hub should be connected:

- between the 3G USB socket and the G3 socket of the wiring centre using the ecoLINK cable supplied. Refer to Section 10 for installation and user guidance.
- between the micro-usb power input socket of the Wi-Fi hub to one of the factory-fitted USB 2.0 type A sockets using the supplied power cable.

### 5.9 CONNECTING THE MODBUS

The Grant Aerona Smart controller communicates with the Aerona R290 heat pump via the 2 cable Mod-Bus connection, which is made between RS485 Terminals H2(+) & H1(-) of the heat pump and the G2 socket of the Grant Aerona Smart controller.

This **MUST** be Shielded cable (Cat 5/6 is acceptable) and the shield ground connected at the heat pump only, stripping back shielding in the Aerona Smart Controller wiring centre. Ensure polarity of connections are matched from the Aerona heat pump to the G2 socket. Refer to Figure 5-9 and Section 7 of UK DOC 0204 - Grant Aerona R290 Installation & Operating instructions.

For Grant Aerona<sup>3</sup> heat pumps refer to Appendix G for further information.

### 5.10 INSTALLATION PACK

Installation Pack P can be purchased from Grant UK to assist with the installation of the Aerona heat pump.

Table 5-3: Installation Pack P

**Order code: HPIDPACKP**

FlexiFoot Kit

Mag One Filter

18L System Kit

32A Isolator

### 5.11 CABLES

Grant Engineering UK recommend to use cable with a cross section of at least 0.5mm<sup>2</sup> for extending 230V electrical circuits, ensuring that the cable is rated for the appropriate voltage and current requirements.

For low-voltage wiring (such as the touchscreen display, smart flow sensor and wired thermostat connections), Cat 5/6 shielded cables should be used, as they are specifically designed for reliable performance in low-voltage applications.

Always ensure the cables meet the necessary standards for safety and performance specific to the intended use.

## ! NOTE !

If Cat 5/6 cables are not shielded, take care to ensure that these cables are NOT running alongside any 230V cables to avoid signal interference.

# 6 SYSTEM CONFIGURATION WITH TOUCHSCREEN DISPLAY

## 6.1 FIRST SWITCH-ON

With installation completed, the Smart controller will need to be configured:

1. Turn on the Smart controller via the wiring centre power switch and allow the software to cycle to the language selection panel. (Refer to Figure 6-1).

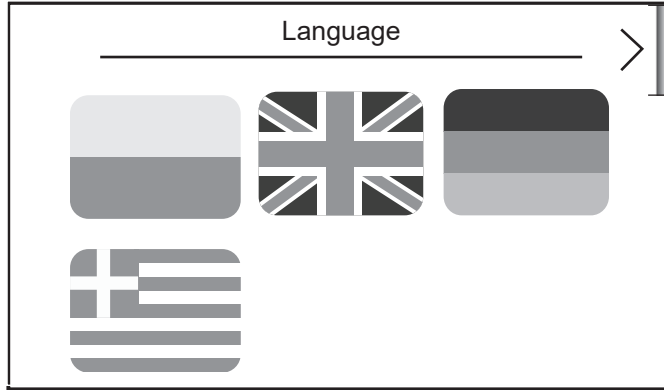

Figure 6-1: Language selection

2. Select required language preference and confirm with >.

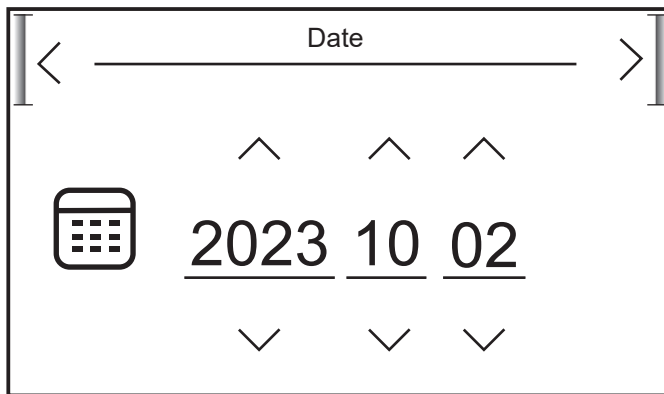

Figure 6-2: Setting date

3. Set the date. Tap the ^ & v to amend the values for year, day and month. Confirm with >. Refer to Figure 6-2.

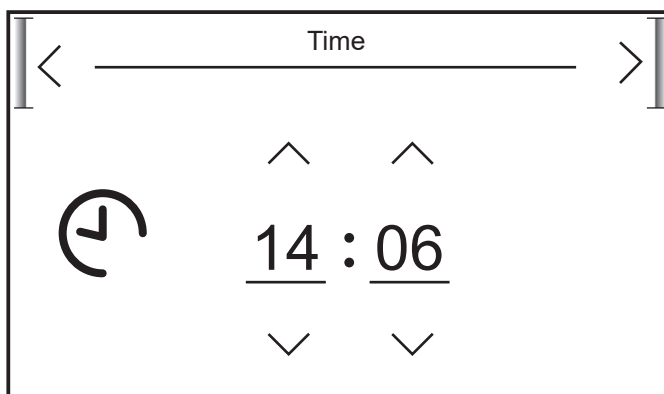

Figure 6-3: Setting time

4. Set the time. Tap the ^ & v to amend the time & confirm with >. Refer to Figure 6-3.
5. The touchscreen will progress to ask if you wish to start a configuration. Tap ✓ to start the configuration creator. Refer to Figure 6-4 and Section 6.2.

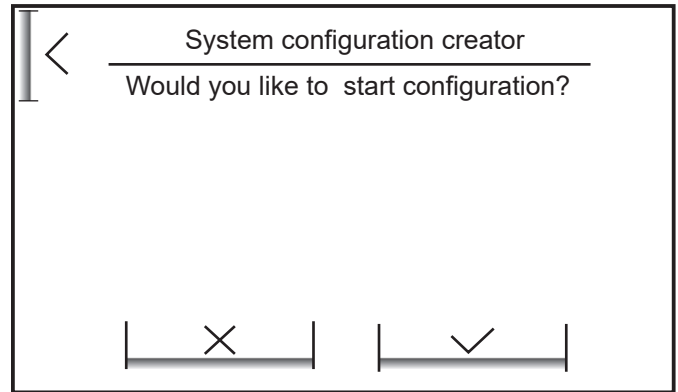

Figure 6-4: Configuration creator

6. If you tap 'X' the controller will take you to the home screen and display "No circuits defined". Refer to Figure 6-5.

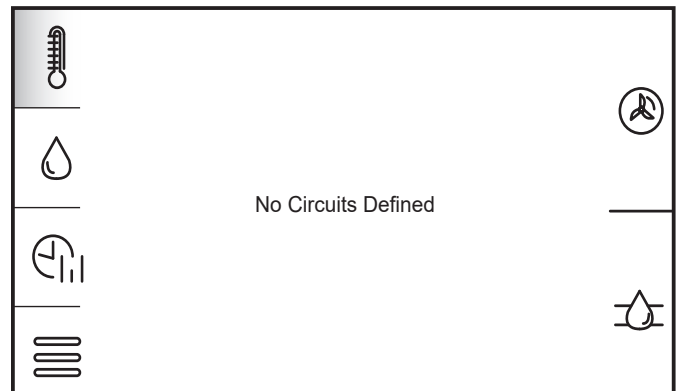

Figure 6-5: No circuits defined

7. To access the system configuration creator you need to access the settings menu / service settings menu. See Section 7 Table 7-1. The service settings password is 0000.

### ! NOTE !

When configuring the system for the first time, it is recommended to use the system configuration creator.

## 6.2 SYSTEM CONFIGURATION CREATOR

The Smart Controller integrated system configuration creator will aid with the setup of the space heating and DHW system within the software of the touchscreen display.

The steps in the configuration creator should reflect the system you have designed and electrically connected to the wiring centre. You must only configure components you have connected (Refer to Section 4.12 Figure 4-3 for wiring centre layout).

### ! NOTE !

Ensure you pay close attention to the devices you connect to the wiring centre and confirm for correct operation.

Using the system you have planned you can follow the system configuration creator steps to configure it within the Smart controller. (Refer to Figure 6-6 for System configuration map).



## ! NOTE !

- X - Confirm option is not required and proceed.
- ✓ - Confirm option is required and proceed.
- > - Confirm configurable option and proceed.
- < - Return to previous step in configuration.

- **Would you like to start configuration?**  
If a system has already been configured you will be prompted to confirm you wish to overwrite the previous setup.
- **How is heat transferred from the source?**  
Confirm if you are using a volumiser or low loss header that the Smart controller will manage or if heat is transferred directly to the primary circuit.
- **Is DHW in the system?**  
The Smart controller will manage the DHW cylinder as well as prioritise DHW on a demand.
- **Is recirculation pump for DHW in system?**  
This would be enabled if you require the Smart controller to manage a secondary circulation pump.
- **Would you like to activate additional heat source?**  
This would be enabled if you are installing an EvoLink Smart to your system for the controller to manage in conjunction with an external heat source e.g. a gas boiler. Refer to Section 8 for further details.
- **Is Outdoor temperature sensor in the system?**  
This will enable the weather control features of the Smart controller.
- **Source of Outdoor temperature sensor**  
Assign an Outdoor temperature sensor. 'Smart Controller' is the outdoor weather sensor supplied with your Smart Controller kit and should be the only option you choose. Refer to Section 5.2.2.

## ! NOTE !

Ensure to select 'Smart Controller' as your outdoor temperature sensor. This will give the best weather compensation values, if the sensor is placed correctly. Refer to Section 5.2.2.

- **Do you want to Configure circuit 1, 2 or 3?**  
Configuration of Heating circuits. Circuit 1 is non-adjustable and this is indicated with a note that Circuit 1 cannot have a mixer.
- **Circuit Name**  
To amend the name of a circuit e.g., "Ground Floor" tap the change name button which will open a qwerty keyboard. To finish tap the enter key.
- **Choose circuit mode**  
Assign the heating emitter type for the circuit. This could be 'RADIATORS' or 'UNDERFLOOR HEATING'.
- **Choose circuit control method**  
Assign a control method from either 'FIXED' or 'WEATHER' control. Individual circuits can be assigned differing methods and can be amended later via the Circuit settings within the system settings menu.
- **Fixed Set point water temperature (Fixed Control)**  
The circuit will operate on a fixed flow temperature. This is the default day flow temperature.
- **Decreasing set point water temperature (Fixed Control)**  
This is the drop in system flow temperature during scheduled night/unattended periods.
- **Heating curve edit (Weather Control)**  
Configure the heating curve for the calculative weather control adjustments for set-point temperatures. Refer to 7.13 for further information on setting & editing the heating curve.
- **Decreasing set point temperature (Weather Control)**  
This is the drop in system flow temperature during scheduled night/unattended periods.

- **Will circuit be controlled with a Mixer?**  
Confirm if the circuit will be controlled by a motorised mixing valve. (Not applicable to Circuit 1)
- **Mixing valve opening time**  
Enter the valve opening time to allow the controller to calculate the opening times for correct temperature mixing. (Refer to Appendix C for further information on the mixing valve).
- **Circuit thermostat choice**  
If required, configure a thermostat to a circuit. A circuit could be uncontrolled, use the touchscreen display or a wired/ wireless thermostat. If either a wired or wireless thermostat is chosen, the touchscreen display will begin the pairing wizard to be followed to pair the individual thermostat to this circuit. Refer to Section 7.3.1.4. . If appropriate, at least one circuit can be controlled by the touchscreen display supplied in the Smart Controller kit.

## ! NOTE !

If more than one wireless thermostat is to be used, you **MUST** ensure you configure the thermostat addresses prior to starting the system configuration creator to avoid conflicts. Refer to Appendix B.4.

- **Circuit Summary**  
The circuit summary displays the parameters you have defined. The circuit structure displays as a pump but is a 230V switched live output (labelled on the wiring centre as H1-P, H2-P & H3-P. This could be connected to a 2-Port motorised valve as is common in the UK. (Refer to Section 4.12, Figure 4-3).
- **Do you want to check configured system?**  
Confirming will activate the manual control function (Refer to Section 8 and Figure 8-2) on the touchscreen display. The components that you have configured via the creator will be shown on the screen. There will be both an icon on the operational button area and the terminal block numbers to which they should be wired to on. Refer to Section 4 for the terminal blocks and associated devices that they control. Tapping the icon will switch the internal relay and send a relevant voltage to activate.
- **Would you like to start screed drying?**  
This would be enabled if you require the Smart controller to begin a pre-configured screed drying process. Refer to Section 7.15 for further details.
- **Do you wish to configure ecoNET? (On first install only)**  
If you wish to configure ecoNET services tap to confirm and follow the steps in the 'ECONET CONFIGURATION WIZARD' to connect the Wi-Fi hub to the wiring centre and/ or pair with the household wireless network. Refer to Section 10 for further details on this process.

## ! NOTE !

For further assistance with circuit configurations and commissioning the installation refer to Appendix F.

# 7 OPERATION & SETTINGS

## 7.1 TOUCHSCREEN DISPLAY

The display is a capacitive touch screen and parameters are edited by touching the selected symbol or area on the display screen.

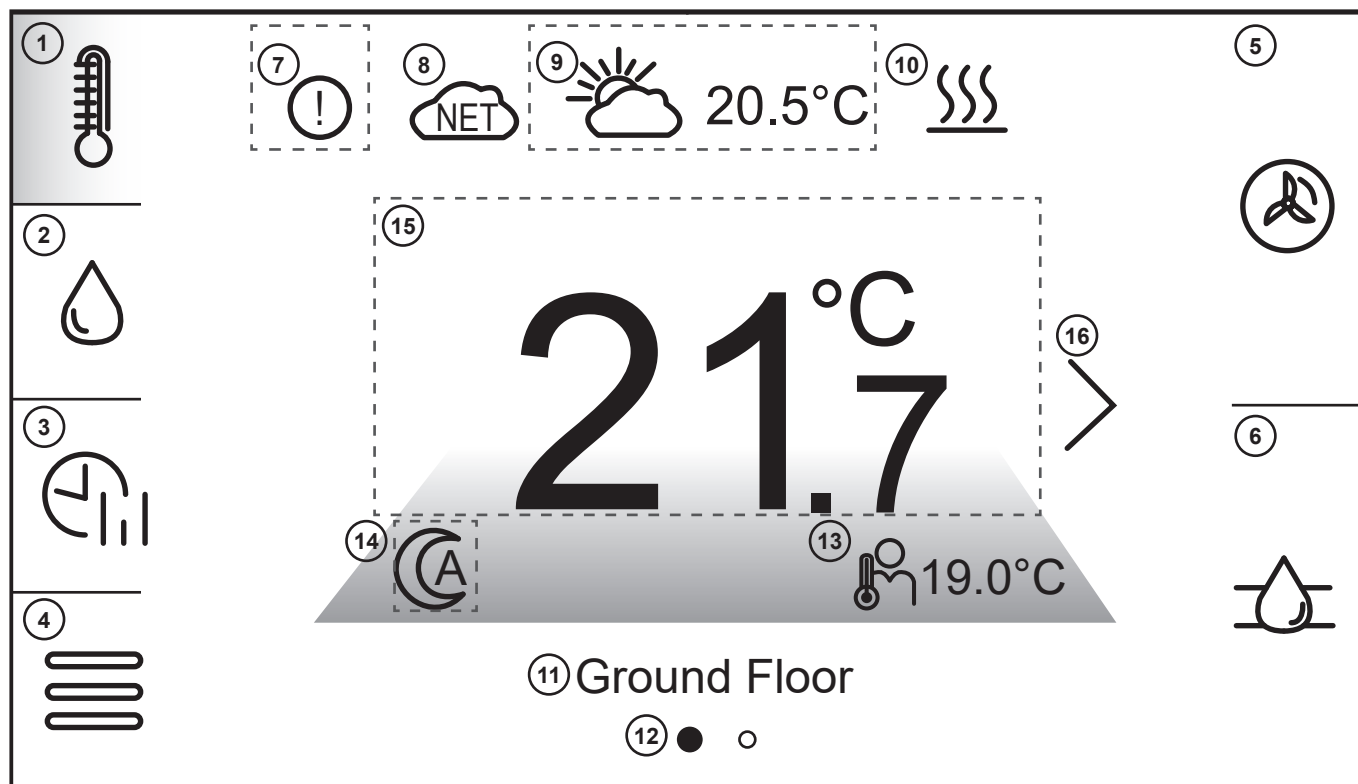

Figure 7-1: Display home screen example

Table 7-1: Touch screen

Number	Symbol	Description
1		Tap to access Heating circuit controls. Refer to Section 7.3.1.1.
2		Tap to access DHW system controls. Refer to Section 7.3.2.1.
3		Tap to access Schedule settings for Heating circuit(s), DHW cylinder and Heat Pump. Refer to Section 7.5.
4		Tap to access to Settings menu. Refer to Section 7.9.
5		Tap to view Heat pump schematic. Refer to Section 7.6.
6		Tap to access active system schematic. Refer to Section 7.7.
7		Indicates there are active alarms on the Smart controller. Tap to view current and previous alarms list.
8		Indicates connection status to ecoNET24 external server. (Green is connected, Red is disconnected)
9		Outdoor temperature value (If outdoor weather sensor support is enabled in the service menu). Tap to view and amend Smart Controller work mode. Refer to Section 7.3.3.
10		Indicates an active heat pump demand.
11	Ground Floor	Circuit title/name
12		Circuit panes available (if more than 1 installed).
13		Circuit user set value.
14		Current circuit work mode. Tap to quick access the circuit work mode screen. Refer to 7.3.1.2 & 7.3.2.2.
15	21.7°C	Current circuit temperature. Tap to access Circuit settings. Refer to 7.3.1 & 7.3.2.
16		Tap to move between multiple circuits (if installed) - The touchscreen can also be swiped to change circuits.

## 7.2 SMART CONTROLLER OPERATION

### 7.2.1 MAIN HEAT SOURCE

The Smart controller manages the operation of the heat pump by activating or deactivating it according to demand for DHW or the space heating circuits.

### 7.2.2 HEAT CIRCUITS

The Smart controller can manage the operation of one non-adjustable and up to two adjustable heat circuits. Water temperature in circuits can set as a fixed flow temperature or by weather, i.e., water temperature in the circuit is calculated in accordance with a temperature from the external temperature sensor. Despite varying outdoor temperature, a room temperature in heated rooms is kept on a set level.

- Dependent circuits – A thermostat assigned for many circuits. For example, temperature readings on a installed panel affect operation of both radiator and underfloor circuits. Commonly one Thermostat in a central location.
- Independent circuit – Connecting thermostats to measure room temperature independently and affecting assigned circuits. It is the way to obtain independency of the circuits, e.g., in case when one part of the building is used for the whole year and the second part is used periodically, e.g., for rent.

If multiple circuits are being controlled you can navigate between them with a swipe of the screen either to the left or the right.

### 7.2.3 DOMESTIC HOT WATER

The Smart Controller manages the operation of the Heat Pump and heating of a DHW cylinder up to a user set temperature. DHW operation can be programmed in time intervals with a minimum operation for disinfection mandatory. While the Smart Controller can also control a DHW secondary circulating pump, their use is not recommended to minimise wasted energy and running costs.

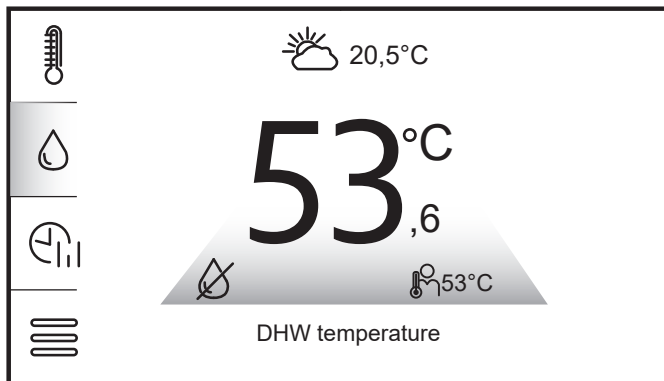

Figure 7-2: DHW temperature display example

## ! NOTE !

The change of the colour under the current value of the temperature of the circulation and DHW cylinder indicates whether the temperature is below (blue), above (red) or the same (green) as the target temperature. Grey indicates the DHW function is Off.

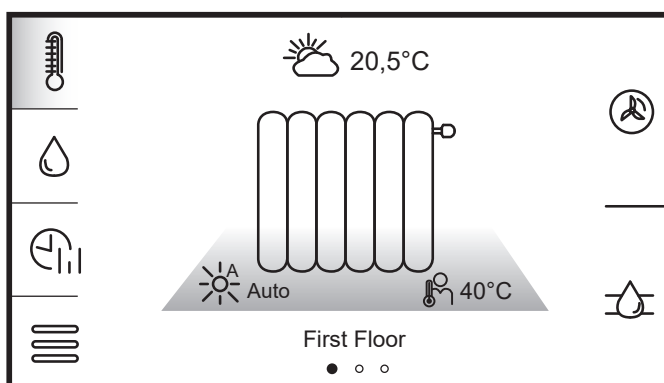

Figure 7-3: Thermostatically uncontrolled circuit display

## ! NOTE !

The circuit is not controlled by a thermostat if a heat emitter icon is displayed on the circuit temperature display screen.

### 7.3 CIRCUIT SETTINGS

Tapping the screen on the displayed information of the DHW or a heating circuit you are viewing (if more than 1 heat circuit installed) will open the circuit settings panel. This will display various options that can be edited. Refer to Figure 7-4.

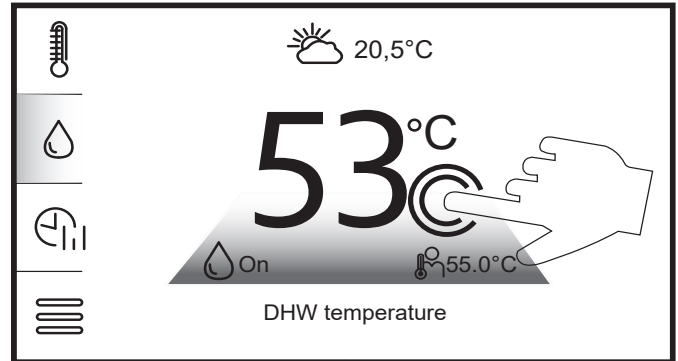

Figure 7-4: Circuit settings access on touch-screen

#### 7.3.1.1 HEAT CIRCUIT SETTINGS

Entering Heat circuit settings will display options the user can edit for the heating circuit. Refer to Figure 7-5.

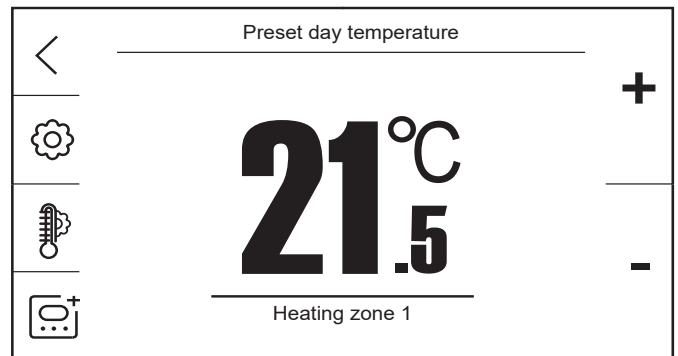

Figure 7-5: Heating circuit settings example





Table 7-2: Heating circuit settings

Button	Function description
<	Navigate back to previous screen.
⚙️	Tap to amend Circuit work mode
🌡️	Tap to view & amend circuit details
📦+	Tap to amend circuit thermostat choice
+	Increase required circuit temperature
-	Decrease required circuit temperature

### 7.3.1.2 CIRCUIT WORK MODE

The Circuit work mode sets the circuit to operate as per the consumer preference.

**Table 7-3: Heating circuit work modes**

Button	Function description
	Auto - Day/Night temperatures based on user schedule
	Off - Circuit will not be heated
	Day Mode - Circuit set to preset day temperature
	Night Mode - Circuit set to preset night temperature
	Boost - Circuit set to day Day mode for 60, 120 or 180 minutes

Tapping 'BOOST' will create a 60 minute space heating period. The icon colour will change and display a counter for the demands remaining time.

The counter can be increased to 120 or 180 minutes with additional taps. If tapped again, the counter will stop and boost will stop.

During boost, the controller will override the circuit schedule to "day mode" to provide heat for the circuit based on the circuit target temperature.

To disable boost, Tap the icon until the icon changes colour to indicate it is off and the counter will disappear.

### 7.3.1.3 HEATING CIRCUIT DETAILS

The heating circuit details panel will display settings of the circuit which you are viewing/editing. Refer to Figure 7-5.

- 'CIRCUIT NAME' – Name of the circuit, e.g., "Ground Floor".
- 'HYSTERESIS' – The value between when a thermostat switches off and back on. The parameter is only available when a thermostat is assigned to the circuit.
- 'PRESET DAY TEMPERATURE' – The target air temperature for when the circuit is set to/scheduled to be in day mode (occupied). The parameter is available for editing only when a thermostat is assigned to the circuit.
- 'PRESET NIGHT TEMPERATURE' (**Setback temperature**) – The target air temperature for when the circuit is set to/scheduled to be in night mode (overnight/unoccupied). The parameter is available for editing only when a thermostat is assigned to the circuit. The setback temperature should be configured to the ideal comfort level minus the temperature value shown in Table 7.4 below (based on heat emitters configured).

**Table 7.4: Recommended setback air temperatures**

Heat Emitter	Setback value(°C)
Fan-Coil	3
Radiators	3
Underfloor Heating	1

- Heating curve – Adjust the heating curve and shift. Refer to Section 6.3.

### 7.3.1.4 HEATING CIRCUIT THERMOSTAT CHOICE





Circuit thermostat choice will allow a circuit thermostat to be configured to the specific circuit.

- None: No Thermostat assigned
- Control Panel: Thermostat within Touchscreen display.
- Wired Thermostat
- Wireless Thermostat
- Contact: External Volt Free Contact (Terminal T1 for Circuit 1 and T2 for Circuit 2 or 3).

### 7.3.2.1 DHW SETTINGS

As per Figure 7-4 when on the DHW (if installed) you will navigate to the DHW settings.







**Table 7-5: DHW settings panel**

Button	Function description
	Navigate back to previous screen.
	Tap to amend DHW work mode
	Tap to access DHW additional settings
	Increase required circuit temperature
	Decrease required circuit temperature

### 7.3.2.2 DHW WORK MODE

DHW work modes give selectable modes as per the consumer preference but also have a optional boost function should the consumer wish (in the event of an expected increase in system demand).

**Table 7-6: DHW work modes**

Button	Function description
	Navigate back to previous screen.
	Boost - Tap to create a temporary 60 minute DHW demand.
	DHW Immersion Boost - Tap to create 60, 120 or 180 minute Immersion boost
	On - DHW demand on temperature fall by hysteresis (Refer to Section 7.3.2.3)
	Off - Cylinder will not be heated
	Schedule - On/Off based on User schedule

Tapping 'BOOST' will create a 60 minute DHW "ON" period. The icon colour will change (light blue) and display a counter for the demands remaining time. To disable boost, Tap the icon again. The icon will change to grey to indicate it is off and the counter will disappear.

Tapping 'DHW IMMERSION BOOST' will create a 60, 120 or 180 minute DHW "ON" period (depending on number of times the icon is tapped. a 4th time will disable the Immersion boost function, setting it to 0 minutes).

DHW Immersion boost will require both an cylinder immersion element connected to the Smart Controller via a Smart immersion relay (Refer to Appendix D) and the 'DHW HEATER' (Refer to Section 7.4.1 and Section 8) to be configured and when activated, the heat pump will start as per boost but in addition it will ignore 'DHW DELAY' parameters and immediately enable the Immersion heater to assist.

During both boost functions, the controller will provide heat to the cylinder to target temperature. Once reached, DHW priority will cease and the controller will switch to space heating, if scheduled. The work mode icon will also change (as per the Icons shown in Table 7-6) during both boost functions to both show it is in boost and display the countdown showing remaining time.

If the temperature in the cylinder falls by the hysteresis value, the controller will enable DHW priority and begin to heat the cylinder again.

### 7.3.2.3 DHW ADDITIONAL SETTINGS

DHW additional settings provides a sub menu for the 'DHW CYLINDER HYSTERESIS' parameters & 'LEGIONELLA PROTECTION' (If additional heater is configured - Refer to Section 7.4).

'DHW HYSTERESIS' is the amount of temperature drop from the user set temperature in the cylinder before the system will demand more heat in a scheduled ON time period.

If the hysteresis setting is too low this can cause potential cycling of the heat demand in an scheduled ON period. Too high can

cause the cylinder to not reach desired temperature and higher energy usage.

### 7.3.3 CONTROLLER WORK MODE

The Smart Controller work mode of the controller is selected by tapping the currently displayed symbol on the main screen in the place where the value of the outdoor temperature is displayed. (Refer to Table 7.1).

**Table 7-7: Controller work mode**

Mode	Description
AUTO	Automatically switches on or off the heating-cooling mode (Cooling not available with Aeron R32 heat pump range), depending on the external temperature.
SUMMER	Adjustable circuit performs the cooling function. (Cooling not available with Aeron R32 heat pump range)
WINTER	Adjustable circuit performs the heating function.

### 7.4 LEGIONELLA PROTECTION

The Smart controller has the function to provide protection against legionella by executing a scheduled temperature increase. This is executed on a weekly basis from within the Smart controller settings using the R290 heat pump only. Alternatively, if a cylinder immersion heater is also wired through the Smart Controller, then the R290 & R32 heat pump and the immersion heater will work together to achieve the 60°C for legionella protection.

For protection against legionella the DHW cylinder needs to be periodically raised to a minimum of 60°C to ensure it is sterilised of any present legionella bacteria.

Care must be given to vulnerable people who may be exposed to potentially life-threatening legionella. This group of people include the elderly, pregnant women, young children and those with breathing difficulties. Where legionella disinfection is required more frequently than once a week, this must be provided by other means.

It is important that this decision is based on the welfare of the occupants and not on energy saving measures.

## ! WARNING !

**If the hot water stored in the cylinder has not been used for a prolonged period of time (e.g., a few days) and has not been stored at 60°C, then it is important that the temperature is raised to at least 60°C for a period of one hour before using the hot water.**

### 7.4.1 ENABLING DHW HEATER SUPPORT

'DHW heater' support must be enabled within the system settings menu of the controller for 'disinfection' to be available.

1. Tap the Settings Menu button.
2. Tap 'SERVICE SETTINGS' and input the password: '0000'. Tap 'ENTER' to confirm.
3. Tap 'Installation controller'.
4. Swipe the touchscreen to move down and tap 'HEATERS'.
5. Tap the button next to 'DHW HEATER' to enable heater support.
6. Tap and set 'DHW DELAY' to '15mins' and confirm. (The 15 min delay can be adjusted. The purpose of this 15 minutes is a delay if in central heating mode at the time the legionella protection is due to come on).
7. Tap '<' to navigate back.

### 7.4.2 CONFIGURING LEGIONELLA SETTINGS

Once DHW heater support has been enabled:

1. Navigate to the DHW circuit screen.
2. Tap the displayed temperature for the cylinder to enter the DHW circuit settings.
3. Tap 'DHW ADDITIONAL SETTINGS' (Refer to Table 7-5).
4. Tap the button next to 'disinfection'. This will expand the display for the individual settings for Legionella protection for configuration.
  - 'Day' - Day to execute Legionella protection.

- 'Start Hour' - Time to start.
- 'Preset temp' - Temperature for DHW cylinder to heat to. (Should not exceed 60°C).

The flow temperature from the R290 heat pump will be automatically set at 5°C **higher than the preset temperature**. Once the preset temperature is achieved the legionella disinfection function will be stopped. The heat pump will resume normal operation.

## ! NOTE !

**Legionella protection works independently of the DHW cylinder schedule and will start even if DHW cylinder is scheduled off.**

### 7.4.3 LEGIONELLA DISINFECTION SCHEDULING

Legionella disinfection should be scheduled in a window that is a minimum of 1 hour after a DHW demand and in a setback heating demand period e.g. Overnight. This is to avoid the least amount of loss in the heating circuits.

The Legionella protection can not be run twice in a week should the schedule be changed within the settings.

### 7.5 TIME SCHEDULES

The Smart Controller allows for programmable time schedules for the Heating Circuit(s), DHW, DHW secondary circulation and the Heat pump itself.

In the situation when the consumer is not at home or at night, the controller can decrease the amount of supplied heat which affects electric consumption.

Time schedules can be set separately for each day of the week or copied across multiple days. If the space is unoccupied Monday to Friday for the same time periods the user could set the hours for Monday and then apply to multiple days.

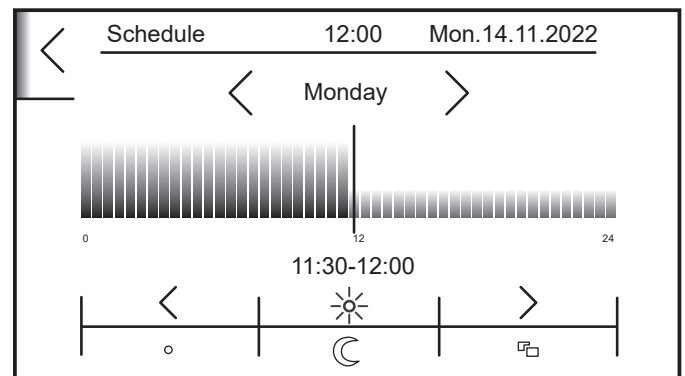

**Figure 7-6: Heating time schedule interface**

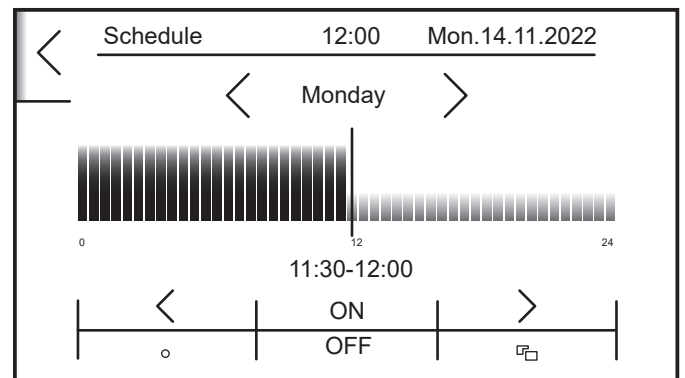

## ! NOTE !

**The ON/OFF time schedule is defined separately for the heat pump and DHW cylinder.**



**Figure 7-7: DHW/Heat pump time schedule interface**

**Table 7-8: Time schedule controls**

Button	Function description
	Navigation Arrows - Weekday selection and time period selection. Navigate the required day or move selected time period in the specified direction.
	Copy to - Copy the currently set schedule to one or multiple days
	Preset Night mode (Setback Temperature) - Target night temperature for circuits will be applied if a thermostat is assigned to the circuit. If not, the decrease will be set to the value of the Water temperature decrease.
	Preset Day mode - Target day temperature setting for circuits will be applied, if a thermostat is assigned to the circuit.
<b>ON</b>	Option is Configured 'ON'
<b>OFF</b>	Option is Configured 'OFF'

**7.5.1 HEATING CIRCUIT SCHEDULE**

The schedule for the heating circuit(s) controls the specific time periods at which the target day and night temperatures are applied.

To amend a heating schedule:

1. Tap the time schedule menu (Refer to Figure and Table 7-1). The schedule icon is available regardless of which circuit or device you are currently viewing.
2. Tap the heating circuit you wish to amend from the options.
3. Modify the day if different to current by tapping navigation arrow. Refer to Figure 7-6.
4. Tap the night mode function and use the navigation buttons to move to the first time period you wish to change (if more than one).
5. Tap day mode and use the right navigational button to alter the time periods. Switch between day and night mode for unoccupied portions of the day.
6. After defining the required time schedule it can be applied to multiple days. Tap 'COPY TO' and tap the days required. Refer to Table 7-8. Confirm with ✓.

**7.5.2 DHW SCHEDULE**

The schedule for the DHW cylinder will turn the cylinder heating function from the heat pump on or off on the selected time periods. If the cylinder temperature falls below hysteresis value in an off time period the heat pump will **not** activate.

To amend the DHW schedule:

1. Tap the time schedule menu (Refer to Figure and Table 7-1). The schedule icon is available regardless of which circuit or device you are currently viewing.
2. Tap 'DHW'.
3. Modify the day if different to current by tapping navigation arrow. Refer to Figure 7-7.
4. Tap the 'OFF' function and use the navigation button to move to the first time period you wish to change. (if more than one).
5. Tap 'ON' and use the right navigational button to alter the time periods. Switch between 'ON and 'OFF' to create multiple intervals based on end-user requirements
6. After defining the required time schedule it can be applied to multiple days. Tap 'COPY TO' and tap the days required. Confirm with ✓. Refer to Table 7-8.

**We recommend to schedule up to 4 x 1 hour on periods in a day with a minimum gap of 1 hour between each.**

**7.5.3 HEAT PUMP SCHEDULE**

The schedule for the heat pump will disable the heat pump from activating in the off periods

To amend the Heat pump schedule:

1. Tap the time schedule menu (Refer to Figure and Table 7-1). The schedule icon is available regardless of which circuit or device you are currently viewing.
2. Tap 'HEAT SOURCE'.
3. Modify the day if different to current by tapping navigation arrow. Refer to Figure 7-7.
4. Tap the 'OFF' function and use the navigation button to move to the first time period you wish to change. (if more than one).
5. Tap 'ON' and use the right navigational button to alter the time periods. Switch between 'ON and 'OFF' to create multiple intervals based on end-user requirements
6. After defining the required time schedule it can be applied to multiple days. Tap 'COPY TO' and tap the days required. Confirm with ✓. Refer to Table 7-8.

**We recommend you leave the Heat pump enabled 'ON' at all times. This does not mean the heat pump will be running continually.**

! NOTE !

**The heat pump schedule will override all other schedules and could cause unwanted heat loss within the space heating or DHW circuits.**

**7.5.4 DHW SECONDARY CIRCULATION SCHEDULE**

The schedule for DHW secondary circulation controls the specific time period(s) at which DHW secondary circulation will be enabled. In addition to scheduling your ON/OFF time periods, you will need to set your secondary circulation cycling parameters. Refer to Section 7.12 and Section 8.

To amend a heating schedule:

1. Tap the time schedule menu (Refer to Figure and Table 7-1). The schedule icon is available regardless of which circuit or device you are currently viewing.
2. Tap 'SECONDARY CIRCULATION'.
3. Modify the day if different to current by tapping navigation arrow. Refer to Figure 7-7.
4. Tap the 'OFF' function and use the navigation button to move to the first time period you wish to change. (if more than one).
5. Tap 'ON' and use the right navigational button to alter the time periods. Switch between 'ON and 'OFF' to create multiple intervals based on end-user requirements
6. After defining the required time schedule it can be applied to multiple days. Tap 'COPY TO' and tap the days required. Confirm with ✓. Refer to Table 7-8.

! NOTE !

**Secondary circulation should be carefully planned to ensure both a satisfactory supply of hot water reaches the specific outlets and there is not too much heat being taken from the DHW Cylinder unnecessarily.**

### 7.5.5 SILENT MODE SCHEDULE (AERONA 290 ONLY)

The schedule for silent mode will enable the feature based on the level configured in the menu screen. Refer to Section 7.6 for more information on accessing silent mode parameters.

To amend the Heat pump schedule:

1. Tap the time schedule menu (Refer to Figure and Table 7-1). The schedule icon is available regardless of which circuit or device you are currently viewing.
2. Tap 'SILENT MODE'.
3. Modify the day if different to current by tapping navigation arrow. Refer to Figure 7-7.
4. Tap the 'OFF' function and use the navigation button to move to the first time period you wish to change. (if more than one).
5. Tap 'ON' and use the right navigational button to alter the time periods. Switch between 'ON and 'OFF' to create multiple intervals based on end-user requirements
6. After defining the required time schedule it can be applied to multiple days. Tap 'COPY TO' and tap the days required. Confirm with ✓. Refer to Table 7-8.

**The use of Silent mode is at the discretion of the installer/homeowner and as such Grant UK accept no liability for faults or issues with the unit if used in this manner.**

### 7.6 HEAT PUMP SCHEMATIC

The heat pump schematic gives a visual preview of the basic operating functions of the heat pump such as working status, Flow/return temperatures as well as being able to configure the operating mode of the heat pump in relation to the system installed.

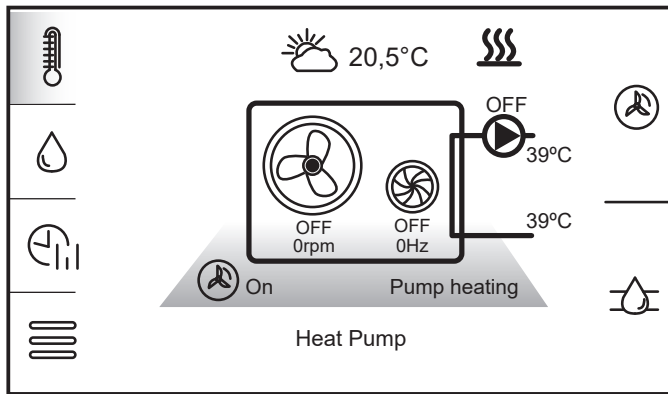

Figure 7-8: Heat pump scheme interface

The heat pump operating modes are accessed by tapping the heat pump schematic icon. Refer to Table 7-9 and Figure 7-8.

Table 7-9: Heat Pump Status

	The heat pump is turned on.
	The heat pump is turned off regardless of the conditions in the system.
	The heat pump is turned on and off according to the set time schedule for the heat pump.

Tapping on the heat pump schematic will open a sub-menu screen that contains some heat pump specific options.

#### 7.6.1 OVERRIDE MODE

'Override Mode' is available when 'additional heat source' (AHS) has been enabled and will cause the AHS to become the primary supply for space heating and DHW demands through the Aerona Smart Controller. Refer to Appendix J

Tap the toggle icon to enable/disable.

### 7.6.2 SILENT MODE (AERONA 290 ONLY)

Silent mode for the Aerona 290 limits the speed of both the compressor and fan(s) during any space heating or DHW demand to reduce the noise of the heat pump.

The 2 options available for silent mode are:

- Silent mode: This enables silent mode based on the level configured and the schedule set (Refer to Section 7.5.5).
- Silent mode level: This configures the level of silent mode required. Level 2 is a greater limit than level 1.

## ! CAUTION !

**Silent mode limits the speed of the compressor and fan(s) and will in turn affect the overall output capacity of the heat pump.**

### 7.7 SYSTEM SCHEMATIC

The system scheme display shows the scheme of the installed and configured system. Icons will change from white to green to indicate they are active such as a motorised valve or the Heat pump. Refer to Figure 7-9 for system schematic example.

Installed diverter valves will indicate via the symbol which direction it is causing the heat to travel. Mixer valves will display a % figure to show their open status.

The system schematic also displays water temperatures from installed sensors (DHW Cylinder, Volumiser Low-Loss Header, Water temperature sensors on adjustable circuits).

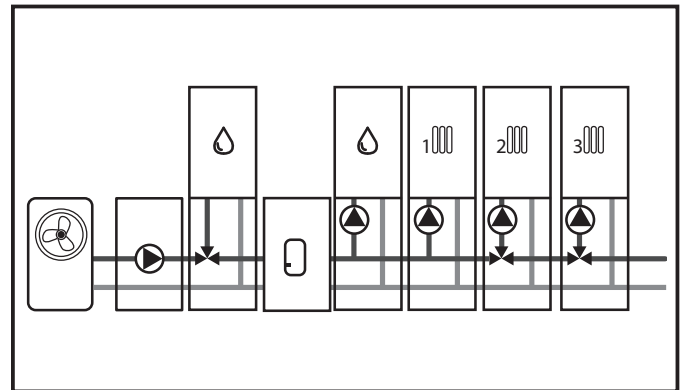

Figure 7-9: System schematic display

## ! NOTE !

**The view of the system schematic depends on the enabled support for the individual circuits, DHW cylinder or volumiser installed.**

### 7.8 CIRCUIT CONTROL

The 3 available heating circuits in the Smart controller are connected and controlled via the following terminals within the wiring centre (Refer to section 5).

Table 7-10: Circuit terminals

Heating circuit	230V Pump/Valve Terminals
1	13(L) & 14(N)
2	15(L) & 16(N)
3	17(L) & 18(N)

Each heating circuit can either have a circulation pump or motorised valve connected to it.

In a conventional system the thermostat (or sensor) will stop the pump or close valve when the actual circuit air temp reaches the target circuit air temp.

### 7.8.1 THERMOSTATIC PUMP BLOCKADE

Thermostatic pump blockade is a hydraulic control feature within the heating circuit setting that enables the Grant Aerona Smart controller to either switch a circuit pump/valve **OFF** (Thermostatic Pump blockade **ON**) or keep the circuit active (Thermostatic Pump blockade **OFF**) based on the status of an installed thermostat monitoring the circuit.

This function can be used to control both mixing and non-mixing circuits. Refer to Section 7.8.1.1 for further details on how to activate and use this function.

Refer to Figure 7-10 and 7-14 for hydraulic control application for Circuit 1 (non-Mixing) and Circuits 2 and 3 (Mixing) utilising 'Thermostatic pump blockade'.

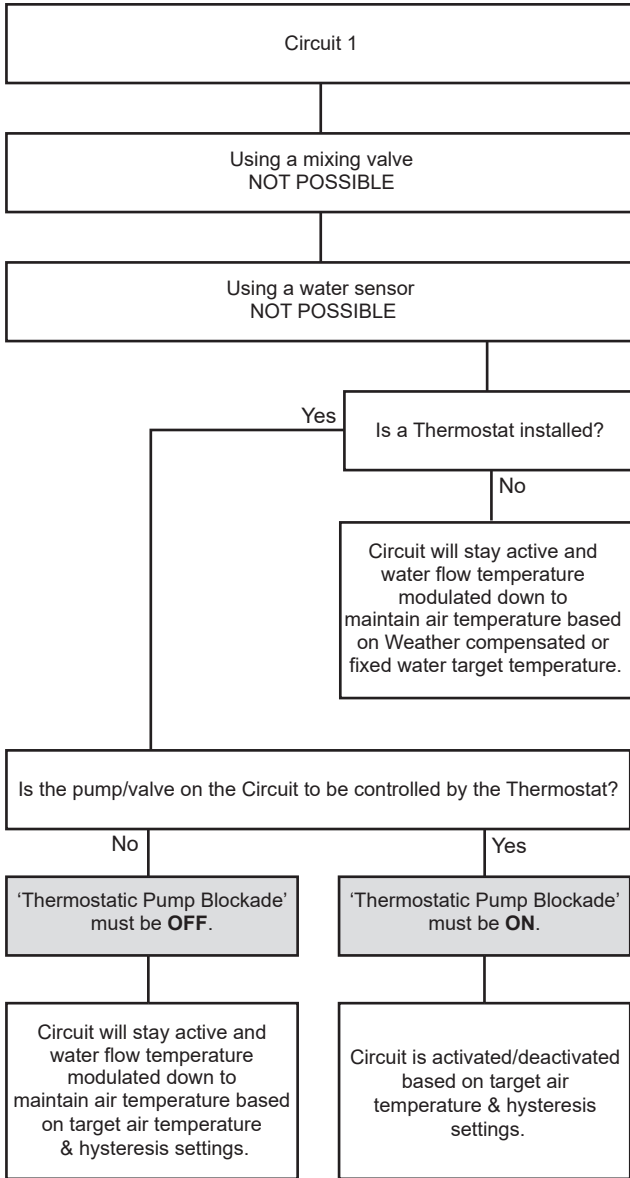

Figure 7-10: Circuit 1 Hydraulic controls

If a thermostat has been installed on any heating circuit, you have the following choices in how to control that circuit:

1. **With pump blockade 'ON'** - Each heating circuit thermostat will control the circulating pump or motorised valve (whichever is installed) for that circuit based on the air temperature the sensor/thermostat is monitoring.
2. **With pump blockade 'OFF'** - The heating circuit will continue to have circulating pump or motorised valve enabled (whichever is installed) but the smart controller will drive down the flow temperature to the minimum value to maintain the target air temperature within the circuit i.e the circuit remains active. This option would be best suited for open loop room optimisation.

### 7.8.1.1 ENABLE THERMOSTATIC PUMP BLOCKADE

To enable Thermostatic pump blockade for a circuit:

1. Tap the Settings menu and then 'SERVICE SETTINGS'. Enter the password: 0000 on the keypad provided and tap 'Enter'. Refer to Table 7-1 and Section 8 for full Service settings parameters listing.

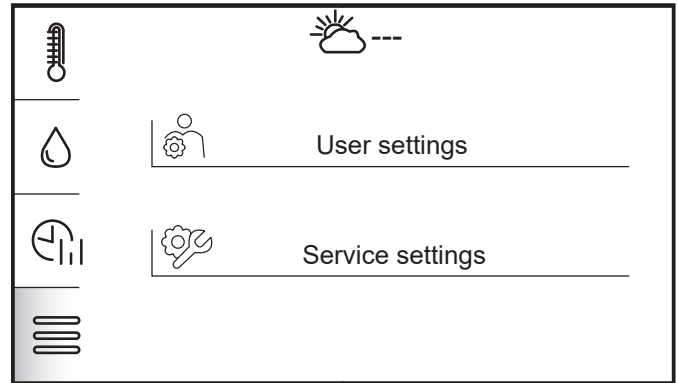

Figure 7-11: Service Settings menu

2. Tap 'Installation controller'
3. Swiping the Touchscreen display scroll down to the desired circuit and select by tapping. (Refer to Figure 7-12).

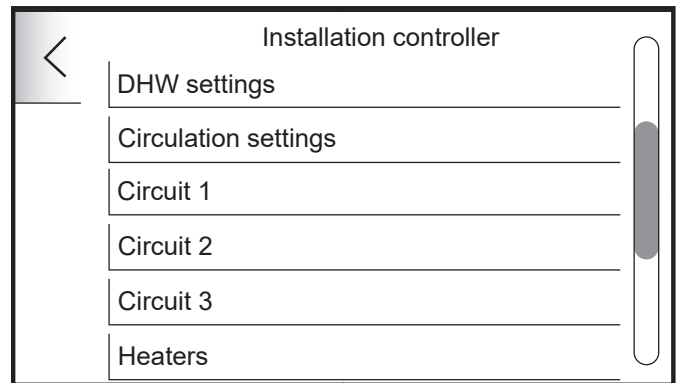

Figure 7-12: Installation controller menu

4. Swiping the touchscreen display scroll down to 'Thermostatic pump blockade'. Tap the icon to switch on. (Refer to Figure 7-13)

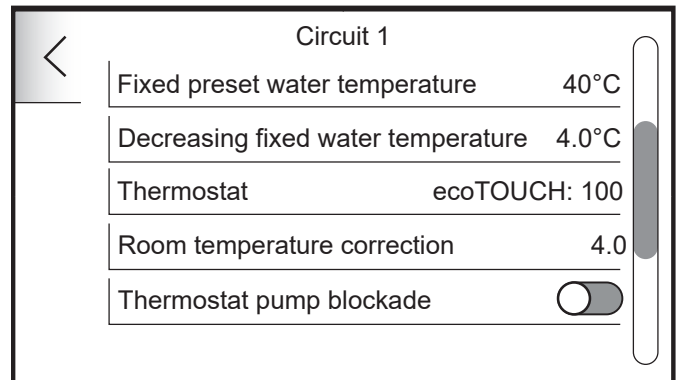

Figure 7-13: Edit Circuit 1 settings

5. Tap the < button to navigate backwards to the home screen.

### 7.8.2 PUMP ONLY/MIXING

Circuits 2 and 3 can function as either a mixing or non-mixing space heating circuit. Using the System configuration creator (Refer to Section 6), you are prompted to confirm if the circuit is controlled with or without a mixer, which in turn will create the circuit and apply the required settings.

If a mixer is not specified, 'PUMP ONLY' will be automatically set to **ON** within the circuit control settings. This will also display the 'CIRCUIT STOP FROM PRESET TEMP' control within the circuit settings. Refer to Figure 7-15.

If a mixer is specified, 'PUMP ONLY' will be automatically set to **OFF** within the Circuit control settings. The menu will not display 'CIRCUIT STOP FROM PRESET TEMP', but will have the option for the mixing valve including the 'VALVE OPENING TIME' which will be used by the Smart Controller to open and close the mixing valve for the desired circuit.

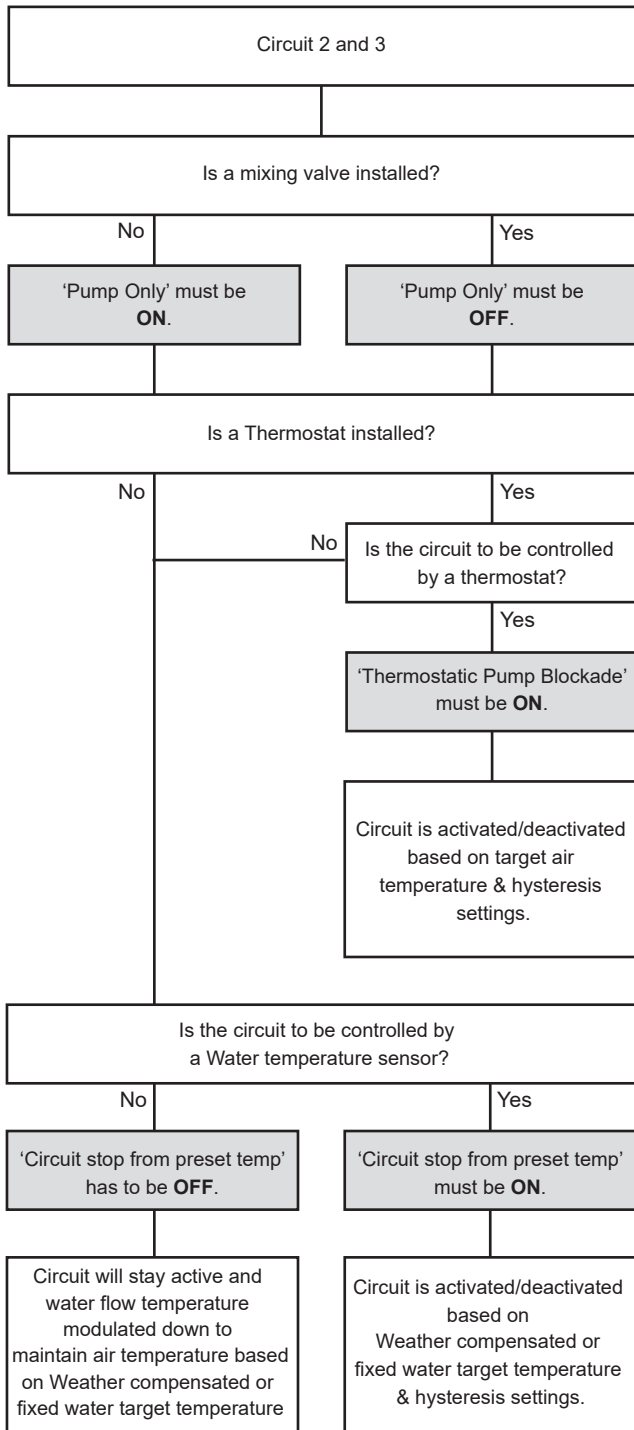

Figure 7-14: Circuit 2&3 Hydraulic controls

### 7.8.2.1 CIRCUIT STOP FROM PRESET TEMP

'CIRCUIT STOP FROM PRESET TEMP' is a hydraulic control feature within a mixing heating circuit setting that enables the Grant Aeron Smart controller to either switch a circuit pump/valve **OFF** (Circuit stop on Preset temp **ON**) or keep the circuit active (Circuit stop on Preset temp **OFF**) based on the status of an installed water temperature sensor on the flow in the circuit. This function can only be used on Circuits 2 and 3 when used as a non-mixing circuit.

Refer to Figure 7-14 for hydraulic control application for Circuit Circuits 2 and 3 (Mixing) utilising 'PUMP ONLY', 'CIRCUIT STOP FROM PRESET TEMP' and 'THERMOSTATIC PUMP BLOCKADE'.

1. **With Circuit stop from preset Temp 'ON'** - The water temperature sensor will monitor the water temperature of the flow into the circuit from the heat pump and directly control the circulating pump or motorised valve closed when the target water temperature is achieved.
2. **With Circuit stop from preset Temp 'OFF'** - The heating circuit will continue to have circulating pump or motorised valve enabled (whichever is installed) but the smart controller will drive down the flow temperature to the minimum value to maintain the target water temperature within the circuit i.e the circuit remains active. This option would be best suited for open loop room optimization.

**! NOTE !**

**If a mixer is installed on circuit 2 or 3, 'Circuit stop from preset temp' will not be available.**

### 7.8.2.2 ENABLE CIRCUIT STOP FROM PRESET TEMP

To enable Circuit stop from preset temp for a circuit:

1. Tap the Settings menu and then 'SERVICE SETTINGS'. Enter the password: 0000 on the keypad provided and tap 'ENTER'. Refer to Table 7-1 and Section 8 for full Service settings parameters listing.
2. Tap 'INSTALLATION CONTROLLER'
3. Swiping the Touchscreen display scroll down to the desired circuit and select by tapping. (Refer to Figure 7-12).
4. Swiping the touchscreen display scroll down to 'CIRCUIT STOP FROM PRESET TEMP'. Tap the icon to switch on. (Refer to Figure 7-15).

**! NOTE !**

**'PUMP ONLY' must to be enabled. Refer to Figure 7-15.**

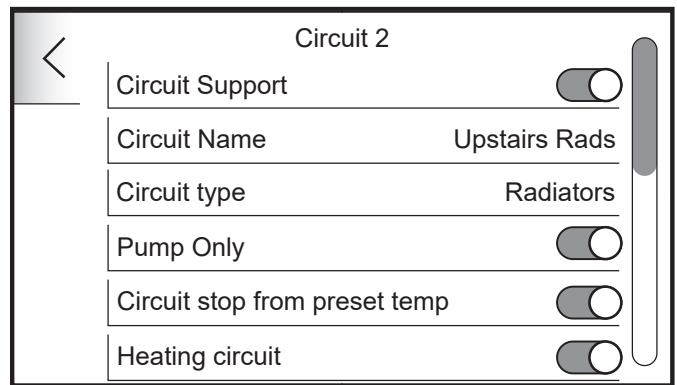
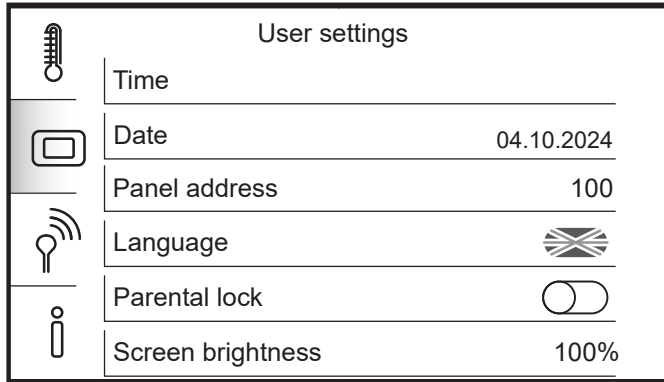

Figure 7-15: Edit Circuit 2 settings

5. Tap the '<' button to navigate backwards to the home screen. Irrespective of whether pipe sensors are used or not, the space heating performance can be adjusted based on user comfort levels using either the Smart controller or via ecoNET24. (Refer to Section 7.13 for Heating curve adjustment guidance)

## 7.9 USER SETTINGS MENU

User settings can be accessed via the settings menu from the touchscreen display. (Refer to Figure and Table 7-1 and Figure 7-1).



**Figure 7-16:** User settings menu

- Time - Time will synchronise with paired thermostats.
- Date
- Panel Address
- Language - Menu language selection.
- Parental Lock - The lock will activate after 5 minutes of inactivity. Unlocking the screen is possible after pressing down the screen for 5 seconds.
- Screen Brightness
- Screen saver - Choose screen saver display: None, Empty, Time, Time and Temps.
- Time to screen saver on
- Brightness in screen saver.
- Alarm sound - Enable/Disable Alarm sounds.
- Key sound - Enable/Disable Key sounds.
- Panel temperature correction.

### ! NOTE !

**The temperature in the room should be measured with an additional temperature sensor and the difference between this measurement and the temperature value displayed by the Touchscreen display should be entered into the value of this parameter.**

Tapping the radio icon symbol (Refer to Figure 7-16):

- Econet configuration wizard - Start the configuration wizard for connecting to econet with the Wi-Fi Hub.
- Econet status - Displays the connection status of Wi-Fi hub and Econet web services. The presented QR code will generate your UID on the device used to scan. This can then be copied for use.
- Wi-Fi settings - Allows the user to manually configure of connection with Wi-Fi Hub. Connection of Wi-Fi and its configuration is described in this manual. Parameters that should be set by the user: SSID, Security type and network access password.

Refer to Section 10 for Wi-Fi hub connection.

Tapping the **i** symbol (Refer to Figure 7-16) will display a panel of sub menus to access system information based on current installation.

- Diagnostic info - Displays information of the current installed system including Heat pump and circuit information, electric counters, flow rates and average COP/EER.
- Alarm list - view list of current and historical alarms.
- Energy Monitor (if enabled) - will display system counter information for the User. IF SD card is inserted the user will also be able to view historical data. Refer to Section 8 - Data registration.
- Firmware Version - View current software versions along with UID and serial number for the installed controller.
- Firmware update - Tap to begin the software updater (if an appropriate SD card is installed).

## 7.10 STORED SYSTEM SETTINGS

The Smart controller can store and recall a default system setting scheme within its memory.

Once the system has been installed and commissioned the applied settings (including demand schedules and Legionella protection) can be stored within the Smart controller. This can be recalled if a setting is perhaps inadvertently changed causing issues with the system.

### 7.10.1 SAVE A SYSTEM DEFAULT

To store the currently set system as a default you will need to:

1. Tap the Settings menu and tap 'SERVICE SETTINGS'. Input the relevant password on the keypad and tap enter. (Password: 0000 - Refer to Section 8).
2. Tap 'INSTALLATION CONTROLLER'.
3. Swipe the screen to scroll down to the bottom and tap 'DEFAULT SETTINGS'.
4. Tap 'SAVE CURRENT SETTINGS AS DEFAULT'.

### 7.10.2 RESTORE SYSTEM DEFAULT

To restore the currently saved default to the Smart Controller:

1. Tap the Settings menu and tap 'SERVICE SETTINGS'. Input the relevant password on the keypad and tap enter. (Password: 0000 - Refer to Section 8).
2. Tap 'INSTALLATION CONTROLLER'.
3. Swipe the screen to scroll down to the bottom and tap 'DEFAULT SETTINGS'.
4. Tap 'RESTORE DEFAULT'.

### ! NOTE !

**Any paired thermostats will need to be re-paired after a system default has been restored. The memory will clear if unpowered for an extended period of time.**

## 7.11 SECONDARY CIRCULATION

Secondary circulation functions allow for the cyclic pumping of hot water from the DHW cylinder to outlets that may be some distance from the cylinder.

The warmer water will be closer to the outlet, thus wasting less water as it will be warmer sooner whilst hot water from the cylinder is pulled behind it.

### 7.11.1 SECONDARY CIRCULATION PUMP

The Terminals allocated for secondary circulation are 11 & 12 (Refer to Section 4). As stated this terminal set is a Switched relay and not a Switched Live.

Any connected pump must be appropriately fused external of the wiring centre (maximum 3.15A) with your Neutral returning to any of the neutral sockets of the wiring centre.

If the pump intended needs a different power supply, you will need to link a live as above but connect the outgoing to A1/A2 of the relay to switch your alternate supply to power on the pump.

### 7.11.2 SECONDARY CIRCULATION SCHEDULING

The smart controller can schedule the periods at which secondary circulation is enabled (Refer to Section 7.5.4). When Secondary circulation is in an ON period, the operation and temperature settings specified will be applied until the OFF period begins.

### 7.11.3 SECONDARY CIRCULATION SETTINGS

With secondary circulation enabled and in a scheduled ON period, the secondary circulation settings will be applied (Refer to Section 8).

These settings follow a cyclic pattern based of:

- Circulation Operation Time - Time in seconds for the Circulation pump to operate.
- Circulation Pause time - Time in minutes between operation.
- Start from temperature - Temperature threshold for operation time. If the cylinder falls below this temperature, the operation will not start.

## 7.12 SYSTEM CONTROLS

### 7.12.1 OFF CIRCUITS DURING CHARGING

'OFF CIRCUITS DURING CHARGING' offers the ability to control all space heating circuits during a DHW demand when a system managed volumiser or low loss header is installed.

If configured ON, 'OFF CIRCUITS DURING CHARGING' will disable all heating circuits outputs from the wiring centre, when a DHW demand is active.

If configured OFF, 'OFF CIRCUITS DURING CHARGING' will not disable all heating circuits outputs from the wiring centre, when a DHW demand is active.

Refer to Section 8 'DHW SETTINGS' to enable or disable.

### 7.12.2 CIRCUIT TEMP. FROM THE HEAT PUMP RETURN

Should mixing valves not be installed on the adjustable circuits, it is possible to remove the water temperature sensor functionality. This will allow the smart controller to operate Circuits 2 and/or 3 to work without the need for a water temperature sensor to be installed and connected.

When set to 'ON' the circuit temperature reading is replaced by the return temperature value of the heat pump. Refer to Section 8 - main heat source.

If a Low Loss header is installed and configured, this function will not be available and circuit water temperature sensors will need to be installed on any active circuits.

## 7.13 WEATHER COMPENSATION

### 7.13.1 HEATING CURVE

Weather compensation can be enabled if an Outdoor Weather sensor is connected. The Outdoor Weather sensor should be enabled and select Regulation method as 'WEATHER'.

The circuit water target temperature is calculated based on the ambient temperature outside the building. The colder it is outside, the higher the water temperature in the circuit will be.

The heating curve is configured per circuit either during system configuration or via the service menu of the controller.

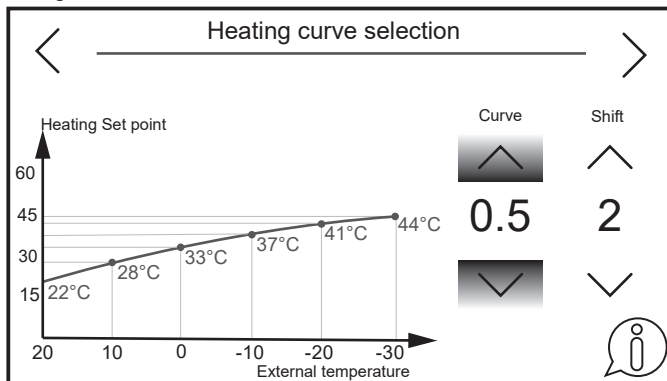

Figure 7-17: Heating curve adjustment

The heating curve selection will provide the line graph representing required target water temperature against outdoor air temperature (Refer to Figure 7-17).

- Tap  $\wedge$  or  $\vee$  of 'CURVE' to align the curve to set a 45°C at -3°C 'External temperature' as a starting point. Refer to Table 7-11 for recommended heating curve settings.
- To further adjust should the temperature points not be satisfactory, Tap  $\wedge$  or  $\vee$  of 'Shift' to move the set curve up or down.

Table 7-11: Recommended Heating Curve

Heat Emitter	Initial Curve Setting
Fan-Coil	1.2 - 1.6
Radiators	1.2 - 1.6
Underfloor	0.2 - 0.6

Refer to Section 7.13.2 for advice on how to further alter the heating curve.

The Smart Controller can increase or decrease the Heat pump target flow temperature, calculated in accordance with the heating curve, if it exceeds the temperature range for the given circuit set in controller service menu.

### 7.13.2 HEATING CURVE ADJUSTMENT

The heating curve is adjustable and should be reviewed to ensure both comfort and economy.

The heating curve can be set as part of the initial system configuration when configuring 'WEATHER' control or be edited after the system configuration has been completed. Refer to Section 7.3.1.3 to access the heating curve setting adjustment, Figure 7-17 and Online resources for a QR code link to a 'how-to' video on adjusting the circuit heating curve.

#### Guidelines for adjusting a heating curve

- If the outdoor temperature drops, and the room temperature increases, the selected heating curve value is too high.
- If the outdoor temperature drops, and the room temperature drops as well, the selected heating curve value is too low.
- If during frosty weather the room temperature is comfortable, but when it gets warmer the room is too cold, it is recommended to increase the Heating curve shift and to select a lower heating curve.
- If during frosty weather the room temperature is too cold, and when it gets warmer the room is too hot, it is recommended to decrease the Heating curve shift and to select a higher heating curve.

Poorly insulated buildings or the use of traditional steel radiators require setting higher heating curves. Well insulated buildings and/or low temperature heat emitters e.g. Underfloor heating, heating curves will have a lower value.

## 7.14 CIRCUIT OPERATION

### 7.14.1 UNCOMPENSATED CIRCUITS

Circuits can be configured with a preset water temperature for the circuit, which can either be managed with or without a thermostat.

#### Without a thermostat

- The circuit will be supplied with a fixed water flow temperature for the scheduled day/occupied time period of the circuit. The temperature is determined by 'FIXED PRESET WATER TEMPERATURE', set during system setup or in the Circuit settings.
- During a scheduled night/unoccupied time period, the fixed water flow temperature will be reduced by the configured value 'DECREASING FIXED WATER TEMPERATURE' set during system setup or in the circuit settings.
- If a water temperature sensor is installed on circuits 2 or 3, you have the ability to stop the circuit demand by enabling 'CIRCUIT STOP FROM PRESET TEMP'. Once the water temperature reaches the desired temperature the circuit demand will stop.

#### With a thermostat

- Target air temperature is set on the assigned thermostat and the 'FIXED PRESET WATER TEMPERATURE' is supplied to the heating circuit and will operate in a similar fashion to without a thermostat
- If 'THERMOSTATIC PUMP BLOCKADE' is enabled, the circuit demand will be stopped once the target air temperature set on the thermostat is reached.
- If 'THERMOSTATIC PUMP BLOCKADE' is not enabled, once the target air temperature is achieved the smart controller will decrease the flow temperature target by the 'DECREASING FIXED WATER TEMPERATURE' value, which is set correctly will maintain the target air temperature. Refer to 7.3.1.3 for recommended setback values based on heat emitters for the circuit.

**7.14.2 WEATHER COMPENSATED CIRCUITS**

The Outdoor weather sensor must be installed and configured to be able to use weather compensation control. Refer to Table 5-4 for recommended weather compensation curve settings based on heat emitters.

'SHIFT' is used to further target a room temperature value. The target preset room temperature should be achieved with a base value of 20°C plus the heating curve shift value.

**Without a thermostat**

- Target flow temperature is calculated based on current ambient air temperature, from the heating curve & shift set for a scheduled day/occupied period.
- If a water temperature sensor is installed, once the target flow temperature is achieved the smart controller will decrease the flow temperature target by the 'DECREASE WATER TEMPERATURE' value, which if set correctly will maintain the target design temperature for the circuit.
- During a scheduled night/unoccupied time period, the water flow temperature will be reduced by the configured value 'DECREASE WATER TEMPERATURE' set during system setup or in the circuit settings.
- If a water temperature sensor is installed on circuits 2 or 3, you have the ability to stop the circuit demand by enabling 'CIRCUIT STOP FROM PRESET TEMP'. Once the water temperature reaches the desired temperature the circuit demand will stop.

**With a thermostat**

- When a target air temperature is set on the assigned thermostat, the smart controller calculates flow based on ambient temperature, heating curve and current circuit air temperature.
- If 'THERMOSTATIC PUMP BLOCKADE' is enabled, the circuit demand will be stopped once the target air temperature set on the thermostat is reached.
- If 'THERMOSTATIC PUMP BLOCKADE' is not enabled, once the target air temperature is achieved the smart controller will use decrease the flow temperature target by the 'DECREASE WATER TEMPERATURE' value, which is set correctly will maintain the target air temperature. Refer to 7.3.1.3 for recommended setback values based on heat emitters for the circuit.

**7.15 SCREED DRYING**

A pre-programmed 30 day screed drying function is available within the Grant Aerona Smart Controller. The flow temperature from the heat pump is slowly increased to aid the drying of laid screed whilst avoiding cracks and shrinkage.

When screed drying has been enabled, the controller will open all configured heating circuits and follow the pre-programmed schedule. Refer to Table 7-12 for the screed drying schedule and temperatures applied.

**Table 7-12:** Screed drying

Days	Flow temperature (°C)
1 - 7	25
8 - 14	30
15 - 21	35
22 - 30	30

**! NOTE !**

**During screed drying, Both circuit schedules and temperatures can not be adjusted.**  
**The circuit work mode icon will change to indicate the screed drying function is active. Refer to Figure 7-18.**

**7.15.1 ACTIVATING SCREED DRYING**

Screed drying can be enabled either by:

- Enabling in the System configuration process  
 Refer to Figure 6-1 for System configuration wizard map. When prompted, Tap the Tick will enable the Screed drying function.  
 or
- Enabling via the System settings menu.
  1. Tap the Settings menu and tap 'SERVICE SETTINGS'. Input the relevant password on the keypad and tap enter. (Password: 0000 - Refer to Section 8).
  2. Tap 'INSTALLATION CONTROLLER'.
  3. Swipe the screen to scroll down and tap 'SCREED DRYING'.
  4. Tap 'ON'.

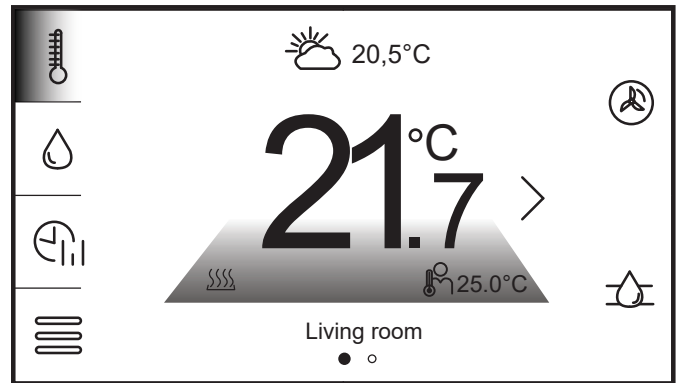

**Figure 7-18:** Screed drying active

**7.15.2 DISABLE SCREED DRYING**

To disable screed drying :

1. Tap the Settings menu and tap 'SERVICE SETTINGS'. Input the relevant password on the keypad and tap enter. (Password: 0000 - Refer to Section 8).
2. Tap 'INSTALLATION CONTROLLER'.
3. Swipe the screen to scroll down and tap 'SCREED DRYING'.
4. Tap 'OFF'.

**7.15.3 SCREED DRYING PROGRESS**

A counter for the progress for the screed drying can be located within the diagnostics menu of the Aerona Smart Controller.

This is displayed as part of the configured circuit(s) information.

To the diagnostics menu:

1. Tap the Settings menu icon and tap 'USER SETTINGS'.
2. Tap the **I** symbol. Refer to Figure 7-16.
3. Either Tap the 'Λ' or '∇' arrows or swipe the screen to scroll down to the heating circuit diagnostic information screen. Refer to Figure 7-19.

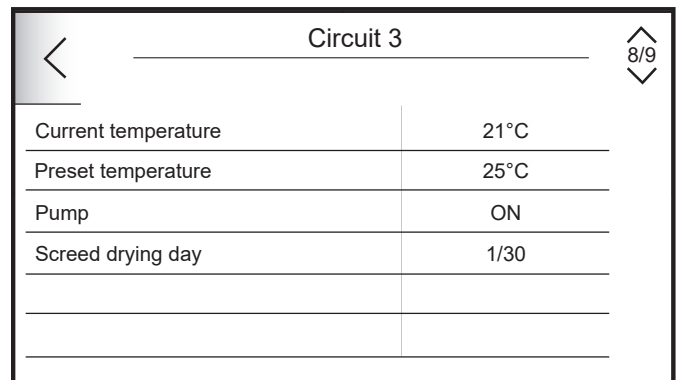

**Figure 7-19:** Screed drying counter

## 7.16 SMART CYLINDER

Your Grant QR2 Smart cylinder has been designed to give many years of trouble-free service and is made from hygienic high grade stainless steel.

### IMMERSION HEATERS

Your Grant QR2 Smart cylinder is fitted with one 3kW immersion heater. Refer to Section 4.2 for further details.

The primary function of the immersion heater in the Grant QR2 Smart cylinder is to provide > 60°C hot water heating for Legionella protection regimes. Refer to Section 7.4.

The immersion heater in the cylinder can also be configured to aid the heat pump in your hot water heating requirements in cold ambient conditions. Refer to Appendix D for more information on supplementary immersion heating support.

The cylinder immersion heater thermostat has been factory-set to position 4.5 (refer to Figure 4-1) to give a hot water temperature of around 61.5°C(±3°C).

The immersion heater incorporates an independent non self-resetting over temperature cut-out device to prevent excessive water temperatures. If this safety cut-out operates it can be re-set. Refer to Section 11.3.

If the problem persists, please contact your installer.

### HIGH LIMIT THERMOSTAT

The high limit (overheat) thermostat will automatically operate if the water temperature reaches 90°C to disable the 2-port motorised zone valve for the DHW.

If the problem persists, please contact your installer.

### TEMPERATURE SETTINGS

The hot water temperatures on the cylinder immersion heater thermostat should not be set any higher than 65°C otherwise nuisance tripping of either the immersion heater safety cut-out will occur. However this temperature could be decreased between 60°C and 65°C if required, to suit your requirements.

Setting a lower target temperature will help to minimise the build-up of lime scale and is likely to increase the longevity of your hot water cylinder.

If you are in any doubt, these temperatures adjustments should be best left to your installer.

### HOT WATER

When a hot tap is turned on there may be a short surge of water, this is quite normal with unvented systems and does not mean there is a fault.

When you first fill a basin the water may sometimes appear milky. This is due to very tiny air bubbles in the water, which will clear very quickly.

## ! WARNING !

If water is seen to flow from either the Temperature & Pressure Relief (T&P Valve) valve or the Expansion Relief Valve (EV) on the cylinder seek expert advice immediately. If the water is flowing from the T&P Valve, immediately:

1. Shut off the electrical supply to the immersion heater(s).
2. Shut down the boiler or other heat sources to the cylinder e.g. solar, heat pump, etc.
3. DO NOT SHUT OFF THE WATER SUPPLY TO THE CYLINDER.
4. Contact your installer to check the system.

### IMPORTANT

Do NOT tamper with any of the Safety controls fitted to the cylinder. If you suspect a fault always contact a competent installer who is qualified to work on unvented water cylinders.

# 8 SERVICE SETTINGS

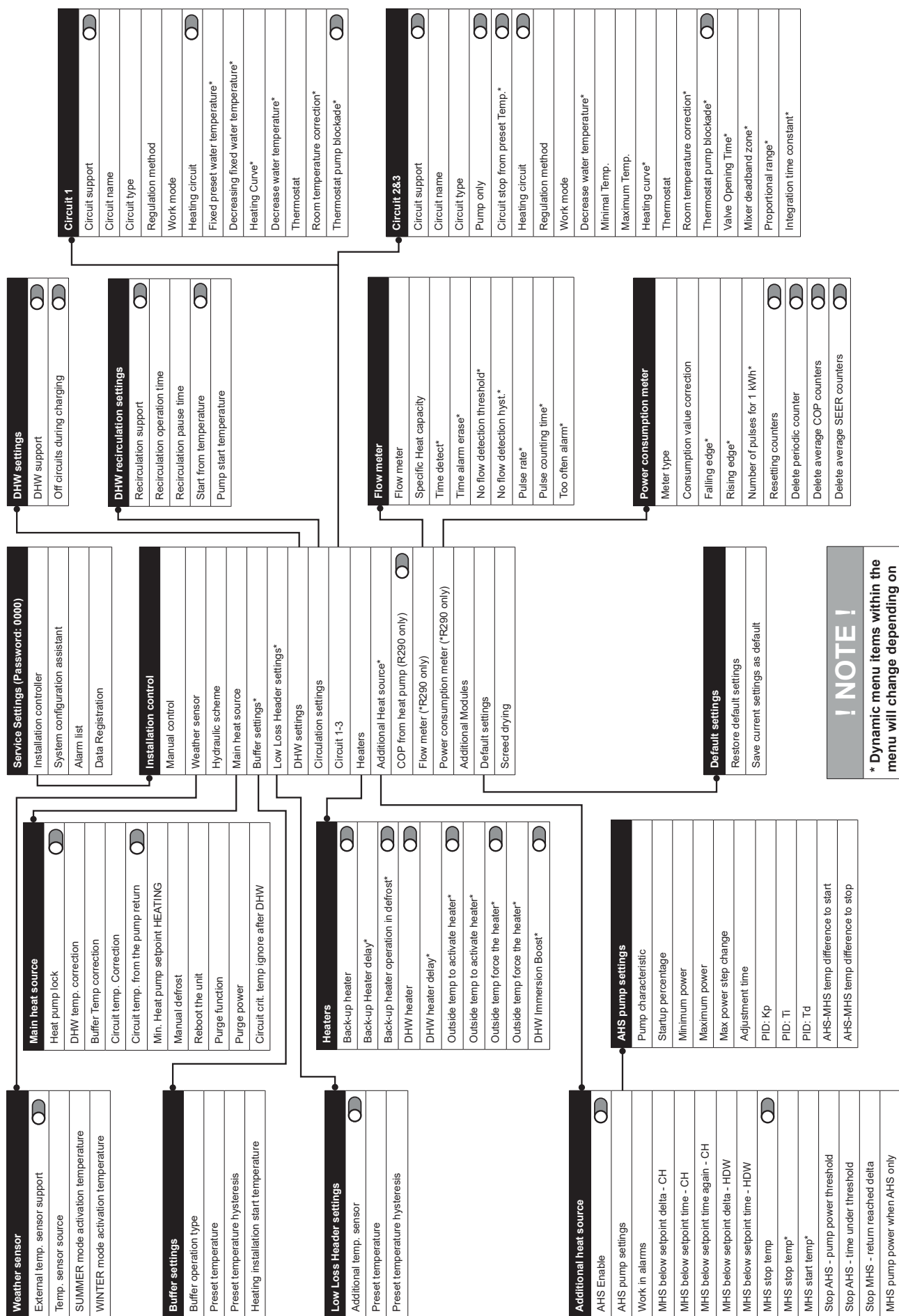
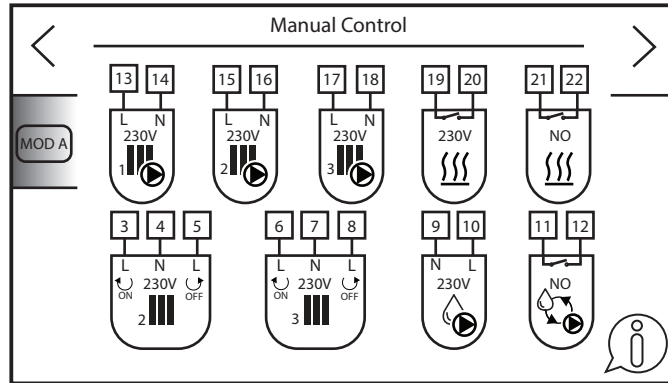

Figure 8-1: System settings menu map

Prerequisites	Parameter	Description
<b>Service Menu - Top Level</b>		
	Installation controller	Tap the enter System settings list.
	System configuration creator	Tap to begin System configuration creator. Refer to Section 6.
	Alarm List	Tap to view alarm list history.
	Data Registration	Tap to configure Data recording and save to SD card slot.

**Installation controller - Manual Control**

Manual Control	<p>Tap to enter manual control menu.</p> <ul style="list-style-type: none"> <li>It is possible to activate individual heating system components to conduct operation tests. Turning on or off a particular selected device is done by tapping the symbol on the screen.</li> <li><b>Note:</b> the controller does not check protection logic, so this menu should be used with awareness of starting outputs in order to avoid damaging the controller and devices connected to its terminals. Long and uncontrolled operation of devices (e.g., pumps) may result in damage.</li> </ul>
----------------	--



**Figure 8-2: Manual Control**

**Installation controller - Weather Sensor**

External temp sensor support	External temp sensor support	Tap the toggle icon to activate or deactivate External temp sensor support. ( <b>Outdoor Weather sensor</b> ). This will be ON if it was configured during System configuration creator.
External temp sensor support: ON	Temp. sensor source	Tap to configure or amend the sensor responsible for monitoring outdoor air temperature. <ul style="list-style-type: none"> <li>Smart Controller - The outdoor weather sensor supplied with the Grant Aerona Smart controller kit.</li> <li>Heat pump - The air temperature sensor installed on the Grant Aerona Heat pump.</li> </ul>
External temp sensor support: ON	Summer mode activation temperature	Tap to configure the ambient temperature at which summer mode is activated.
External temp sensor support: ON	Winter mode activation temperature	Tap to configure the ambient temperature at which summer mode is deactivated.

**Installation controller - Hydraulic Scheme**

		Entering this option will display available options to select. Choose and confirm with ✓. <ul style="list-style-type: none"> <li>Direct - No Hydraulic Separation present.</li> <li>Buffer</li> <li>Low Loss Header</li> </ul>
--	--	--

**Installation controller - Main Heat Source**

	Heat Pump Lock	Tap to toggle Heat pump lock On/Off. Enabling this will open the Volt Free switch in Terminals 23 & 24 to disable heat pump demands.
	DHW Temp correction	Tap to adjust the increase of the target flow for DHW temperature in DHW mode.
Hydraulic Scheme: Buffer/ Low Loss Header	Buffer Temp correction	Tap to adjust the increase of the target flow for the Buffer/Low Loss header temperature when enabled.
	Circuit temp correction	Tap to adjust the increase of the target flow for space heating circuit temperature value in heating mode.
	Circuit temp. from pump return	Tap to toggle for all circuits temperatures to be measured via the heat pump return temperature. Enabling this will negate the need for water temperature sensors for circuit 2 and 3 if not using the mixing functions.
	Min. Heat Pump setpoint HEATING	Tap to configure minimum heat pump flow temperature for heating circuits.
	Manual defrost	Tap to trigger a manual defrost cycle on the unit. ( <b>R290 only</b> )
	Reboot the unit	Tap to trigger a power cycle of the unit. ( <b>R290 only</b> )
	Purge function	Tap to enable the circulating pump in the unit. ( <b>R290 only</b> )
	Purge power	Tap to configure pump speed in the purge function from 0 to 100% ( <b>R290 only</b> )
	Circuit crit. temp ignore after DHW	Tap to configure time delay for disabling circuit output if water temperature is above 45°C when underfloor heating is configured (Applicable to Circuits 2 and 3 only)-

Prerequisites	Parameter	Description
<b>Installation controller - Buffer settings</b>		
Hydraulic scheme: Buffer	Buffer operation type	Tap to configure the number of sensors with which the buffer will work. <ul style="list-style-type: none"> <li>One sensor - Water temperature sensor connected to BB terminal.</li> <li>Two sensors. - Water temperature sensors connected to BB &amp; BT terminals.</li> </ul>
Hydraulic scheme: Buffer	Preset temperature	Tap to configure target buffer temperature value.
Hydraulic scheme: Buffer	Preset temperature hysteresis	Tap to configure the temperature value drop from preset temperature at which the buffer is heated.
Hydraulic scheme: Buffer	Heating installation start temp	Tap to configure the temperature value at which the circuit pumps will be turned on.
<b>Installation controller - Low Loss Header</b>		
Hydraulic scheme: Low Loss Header	Additional temp. sensor	Tap to enable or disable the water temperature sensor for the Low Loss Header. (Connected to terminal: BB). <i>If disabled, the temperature value is measured from the return temperature on the heat pump.</i>
Hydraulic scheme: Low Loss Header	Preset temperature	Tap to configure the target temperature of the water in the Low Loss Header. <i>If 'ADDITIONAL TEMP SENSOR' is ON, this is measured from terminals 'BB Sensor'</i> <i>If 'ADDITIONAL TEMP SENSOR' is OFF, this is measured from Heat pump return.</i>
Hydraulic scheme: Low Loss Header	Preset water hysteresis	Tap to configure the temperature value drop from 'preset temperature' at which the Low Loss Header is heated.
<b>Installation controller - DHW settings</b>		
	DHW cylinder	Tap the toggle to enable or disable DHW cylinder support.
	Off circuits during charging	Tap to toggle DHW priority On or Off when volumiser/low loss header installed. If set 'OFF', heating circuits remain active in a DHW demand.
<b>Installation controller - Circulation settings      We do not recommend the use of Secondary DHW circulation in domestic installations.</b>		
	Circulation support	Tap the toggle icon to activate or deactivate secondary circulation support.
Circulation support: ON	Circulation operation time	Tap to configure the DHW circulation pump operation time. It determines the working time after a break in the circulation pump operation. The DHW circulation pump operates periodically.
Circulation support: ON	Circulation pause time	Tap to configure the DHW circulation pump pause time. Defines the time interval between activations of the circulation pump. The DHW circulation pump operates periodically.
	Start from temperature	Tap the toggle to enable or disable 'PUMP START TEMPERATURE'.
Start from temperature: ON	Pump start temperature	Tap to configure target cylinder temperature threshold to activate the circulation pump. <i>It will be turned off if the temperature of the DHW cylinder is lower than the Pump start temp.</i>
<b>Installation controller - Circuit 1 - (Non-mixing Circuit)</b>		
	Circuit support	Tap the toggle icon to activate or deactivate the circuit support.
	Circuit name	Name of the circuit set by user. Tap to open and adjust.
	Circuit type	Configure the type of heat emitters for the circuit. Tap to open and amend. Circuit 1 is a non-mixing circuit. Radiators or Fan-Coil only.
External temp sensor support: ON	Regulation Method	Tap to configure circuit flow regulation method. <ul style="list-style-type: none"> <li>Fixed - constant set temperature of water in the circuit is maintained.</li> <li>Weather - water temperature is related to Outdoor weather sensor. Outdoor weather sensor required.</li> </ul> <i>If "EXTERNAL TEMP SENSOR SUPPORT" is not ON, the Smart controller will only allow fixed circuit flow.</i>
	Work Mode	Tap to amend Heating Circuit work mode. <ul style="list-style-type: none"> <li>OFF</li> <li>Day – Circuit will use higher target circuit temperature.</li> <li>Night – Circuit will use lower target circuit temperature.</li> </ul> <i>"DECREASING FIXED WATER TEMPERATURE" or "DECREASE WATER TEMPERATURE" will be applied when the controller is in night mode.</i> <ul style="list-style-type: none"> <li>Schedule – Day or Night mode is set depending on the time schedule.</li> </ul>
	Heating circuit	Tap to adjust the space Heating Circuit On or Off.
Regulation Method: Fixed	Fixed preset water temperature	Tap to adjust the fixed preset water temperature for day mode. The Heat pump heats until the fixed preset water temperature is reached.
Regulation Method: Fixed	Decreasing fixed water temperature	Tap to adjust decreasing fixed water temperature. If Regulation method is fixed, this is the value of flow temperature decrease for night mode.
Regulation Method: Weather	Heating Curve	Tap to view and adjust Heating curve for Circuit 1.
Regulation Method: Weather	Decrease water temperature	Tap to view and adjust value of flow temperature decrease when in night mode.
	Thermostat	Displays name of Thermostat currently monitoring the Circuit. Tap to configure thermostat for circuit. <ul style="list-style-type: none"> <li>None</li> <li>Wired - Refer to Appendix A</li> <li>Wireless - Refer to Appendix B</li> <li>Control Panel - Thermostat within the touchscreen display.</li> <li>Contact - External Volt Free contact connection. T1 for circuit 1, T2 for Circuit or 3. Refer to Section 5 for Terminal connections.</li> </ul>

Prerequisites	Parameter	Description
Thermostat configured	Room temperature correction	Tap to view and adjust value of automatic correction of room temperature. This is carried out in accordance with the following formula: <ul style="list-style-type: none"> <li>Target temperature with correction = Target air temperature of the thermostat assigned to the circuit minus Current temperature of the thermostat assigned to the circuit x Room temperature correction.</li> <li>By default, the Room temperature correction value is 4.0, and the value range is 0 - 10. It is necessary to find appropriate value of the Room temperature correction. The higher the coefficient, the greater the correction of target circuit temperature. If the setting is "0", the target circuit temperature is not corrected. Note: setting a value of the room temperature coefficient too high may cause cyclical fluctuations of the room temperature.</li> </ul>
Thermostat configured	Thermostatic pump blockade	Tap to toggle circuit pump control status when a thermostat is active for the circuit. Refer to Section 7.8. <ul style="list-style-type: none"> <li>ON - when the target room temperature is met, the circuit pump/valve is disabled.</li> <li>OFF - when the target room temperature is met, the circuit pump/valve is not disabled.</li> </ul>
<b>Installation controller - Circuit 2 &amp; 3 - (Mixing Circuit)</b> All options from Circuit 1 are applicable with the below additions.		
	Circuit type	Tap to adjust the circuit heat emitters. <ul style="list-style-type: none"> <li>Radiators</li> <li>Fan-coil</li> <li>Underfloor heating</li> </ul>
	Pump Only	Tap the toggle icon to configure Pump only On or Off. <ul style="list-style-type: none"> <li>ON - Mixing Disabled</li> <li>OFF - Mixing Enabled</li> </ul>
Pump Only: ON	Circuit stop from Preset Temp	Tap to toggle icon to configure circuit pump control status using Water Temperature sensor on circuit flow. <ul style="list-style-type: none"> <li>ON - when target flow temperature is met, the circuit pump/valve is disabled.</li> <li>OFF - when target flow temperature is met, the circuit pump/valve is not disabled.</li> </ul>
	Minimal Temp	Tap to adjust minimum target water temperature into the circuit. Minimum value is determined by 'MIN. HEAT PUMP SETPOINT HEATING'.
	Maximum Temp	Tap to adjust the maximum target water temperature permitted into the circuit. <i>Maximum value is determined by the Heat pump and the circuit type.</i>
Pump only: OFF	Valve Opening Time	Tap to adjust the opening time for connected motorised mixing valve. (Fully closed to fully open)
Pump only: OFF	Mixer deadband zone	Tap to adjust the temperature insensitivity of mixer adjustment.
Pump only: OFF	Proportional Range	Tap to adjust the mixer actuator proportional movement.
Pump only: OFF	Integration time constant	Tap to adjust the time for actuator reaction for temperature deviation.
<b>Installation controller - Heaters (Refer to Appendix D)</b>		
	Back-up heater	Tap the toggle icon to enable or disable the Back-up immersion heater support. <i>Back-up heater support will activate with a Buffer or Low Loss Header configured.</i>
Back-up heater: ON	Back-up heater (delay)	Tap to adjust the delay time for activating the Back-up immersion heater after a heat pump space heating demand starts. A Low Loss Header must be configured for supplementary heating.
Back-up heater: ON	Back-up heater operation in defrost	Tap the toggle icon to enable or disable Defrost support via the Aerona Smart Controller. <b><i>This will trigger H1 (Terminals 19 &amp; 20) when the heat pump enters a defrost state in any installed systems.</i></b>
	DHW heater	Tap the toggle icon to enable or disable the DHW Immersion heater support. <i>DHW heater support is required for Legionella protection. Refer to Section 7.4.</i>
DHW heater: ON	DHW heater (delay)	Tap to adjust the delay time for switching on the DHW immersion heater after a DHW demand starts.
Back-up heater: ON and/or DHW heater: ON	Outside temp to activate heater	Tap the toggle icon to enable or disable Outside temp to activate heater. <i>Enabling will create a new selectable box for configuration. (See below)</i>
Outside temp to activate heater: ON	Outside temp to activate heater	Tap to adjust the external temperature value beyond which the DHW heater will be activated.
Back-up heater: ON and/or DHW heater: ON	Outside temp force the heater	Tap the toggle icon to enable or disable Outside temp force the heater. <i>Enabling will create a new selectable box for configuration. (See below)</i>
Outside temp force the heater: ON	Outside temp force the heater	Tap to adjust the external temperature value at which the heater support will be permanently turned on during heat pump operation.
DHW heater: ON	DHW Immersion Boost	Tap to enable DHW Immersion boost for DHW demands. This enables button functionality within DHW work mode settings panel. Refer to Section 7.3.2.2 for further information.

Prerequisites	Parameter	Description
<b>Installation controller - Additional heat source (R290 only - Refer to Appendix J)</b>		
	AHS Enable	Toggle icon to activate or deactivate Additional heat source support. <b>This will be ON if it was configured during System configuration creator.</b>
AHS Enable: ON	AHS Pump settings	Sub menu for PWM pump control. (Refer to Table J-2)
<b>Sub menu - AHS pump settings</b>		
	Pump characteristic	Configure pump type for operation H:Heating S: Solar
	Startup percentage	PWM startup power.
	Minimum power	Minimum power setting of PWM pump
	Maximum power	Maximum power setting of PWM pump
	Max power step change	PWM power adjustment for temperature adjustments
	Adjustment time	Time for PWM power step to be adjusted
	PID: Kp	PID Controller settings
	PID: Ti	
	PID: Td	
	AHS-MHS temp difference to start	Temperature delta between Boiler flow and system flow for PWM pump to start.
	AHS-MHS temp difference to stop	Temperature delta between Boiler flow and system flow for PWM pump to stop.
AHS Enable: ON	Work in alarms	Allow EvoLink Smart to operate when MHS in Alarm state.
AHS Enable: ON	MHS below setpoint delta - CH	Temperature below setpoint MHS needs to achieve in setpoint time for space heating demands
AHS Enable: ON	MHS below setpoint time - CH	Time value in which MHS should reach setpoint delta value for space heating demands
AHS Enable: ON	MHS below setpoint time again - CH	Time value counter from first setpoint in which MHS should reach setpoint delta
AHS Enable: ON	MHS below setpoint delta - HDW	Temperature below setpoint MHS needs to achieve in setpoint time for DHW demands
AHS Enable: ON	MHS below setpoint time - HDW	Time value in which MHS should reach setpoint delta value for DHW demands
AHS Enable: ON	MHS stop temp	Toggle icon to enable MHS shut off at configured temperatures
AHS Enable: ON	MHS stop temp	Temperature value at which the MHS is deactivated for demands
AHS Enable: ON	MHS start temp	Temperature value at which the MHS is activated for demands
AHS Enable: ON	Stop AHS - pump power threshold	PWM pump speed to start under threshold counter to turn of AHS during a demand for space heating
AHS Enable: ON	Stop AHS - time under threshold	Time counter for pump power threshold to be under value to turn off AHS during a demand for space heating
AHS Enable: ON	Stop MHS - return reached delta	Temperature value of delta between return flow temperature to MHS and maximum Flow temperature to stop MHS compressor
AHS Enable: ON	MHS pump power when AHS only	MHS PWM pump speed when AHS only.
<b>Installation controller - Power Consumption meter</b>		
	Meter type	Entering this option will display available options to select. Choose and confirm with ✓. <ul style="list-style-type: none"> <li>• None</li> <li>• Pulse</li> <li>• Heat Pump</li> </ul>
Meter type: pulse or heat pump	Consumption value correction	Value correction of energy reading in watts.
Meter type: pulse	Falling edge	Tap to configure counting pulses on the falling edge of the signal.
Meter type: pulse	Rising edge	Tap to configure counting pulses on the rising edge of the signal.
Meter type: pulse	Number of pulses for 1kW/h	Tap to configure the number of pulses as per 1kW/h of electricity consumed.
Meter type: pulse or heat pump	Resetting counters	Toggle to reset of counters for COP and EER.
Meter type: pulse or heat pump	Delete periodic counter	Toggle to reset the pulse counter that counts the periodic consumed electric energy.
Meter type: pulse or heat pump	Delete average COP counters	Toggle to reset the counters for the coefficient of performance in heating mode.
Meter type: pulse or heat pump	Delete average SEER counters	Toggle to reset the counters for the electricity consumption efficiency in heating mode.

Prerequisites	Parameter	Description
<b>Installation controller - Flow meter (Refer to Appendix E)</b>		
	Flow meter	Tap to select the flow meter required. <i>Choose from available options and confirm with ✓.</i> <ul style="list-style-type: none"> <li>• Default</li> <li>• Pulse</li> </ul>
Flow meter: Default	Default flow meter	Tap to configure the default flow in the circuit. When exceeded, a no-flow alarm will be reported.
	Specific Heat capacity	Tap to configure the coefficient of liquid used to transfer heat in the heating circuits.
	Time detect	Tap to configure the time after which the no-flow alarm will be reported.
	Time alarm erase	Tap to configure the time after which the no-flow alarm will be reset. <i>The controller will not report an alarm.</i>
	No flow detection threshold	Tap to configure the flow value below which the alarm "Flow error" will be reported.
	No flow detection hysteresis	Tap to configure the No Flow detection hysteresis value at which the alarm will be turned off. <i>If the actual flow rises above the value of No flow detection threshold plus No flow detection hysteresis.</i>
Flow Meter: Pulse	Pulse rate	Tap to configure the Flow sensor pulse rate to calculate flow.
Flow Meter: Pulse	Pulse counting time	Tap to configure the Flow sensor pulse count time duration.
	Too often alarm	Tap to configure the too frequent no-flow alarm detection threshold to limit the frequent reporting of the no-flow alarm.
<b>Installation controller - COP from heat pump (R290 only)</b>		
	COP from heat pump	Tap to toggle COP to be calculated from heat pump readings ON or OFF. If this is enabled it will remove 'Flow sensor' and Power consumption meter' menus from the list. Readings can be viewed from the diagnostic menu in user settings.
<b>Installation controller - Default Settings (Refer to Section 7.10)</b>		
	Restore default settings	Tap to recall and apply previously saved default settings.
	Save current settings as default	Tap to save current settings as default. This will save the current setup of the Grant Aeron Smart controller to memory.
<b>Installation controller - Screed drying (Refer to Section 7.15)</b>		
	Screed drying	Tap to trigger the pre-programmed screed drying function.

## ! NOTE !

During the initial setup the smart controller disables support for all heating circuits, DHW cylinder, volumiser, and circulation pumps. Depending on the hydraulic system used, these circuits must be turned on.

## ! NOTE !

We do not recommend the use of Secondary DHW circulation in domestic installations.

## ! NOTE !

Only microSD HC memory card (max. 32 GB, FAT32 file format) can be used with the Aeron Smart controller.

# 9 HEAT PUMP PARAMETERS

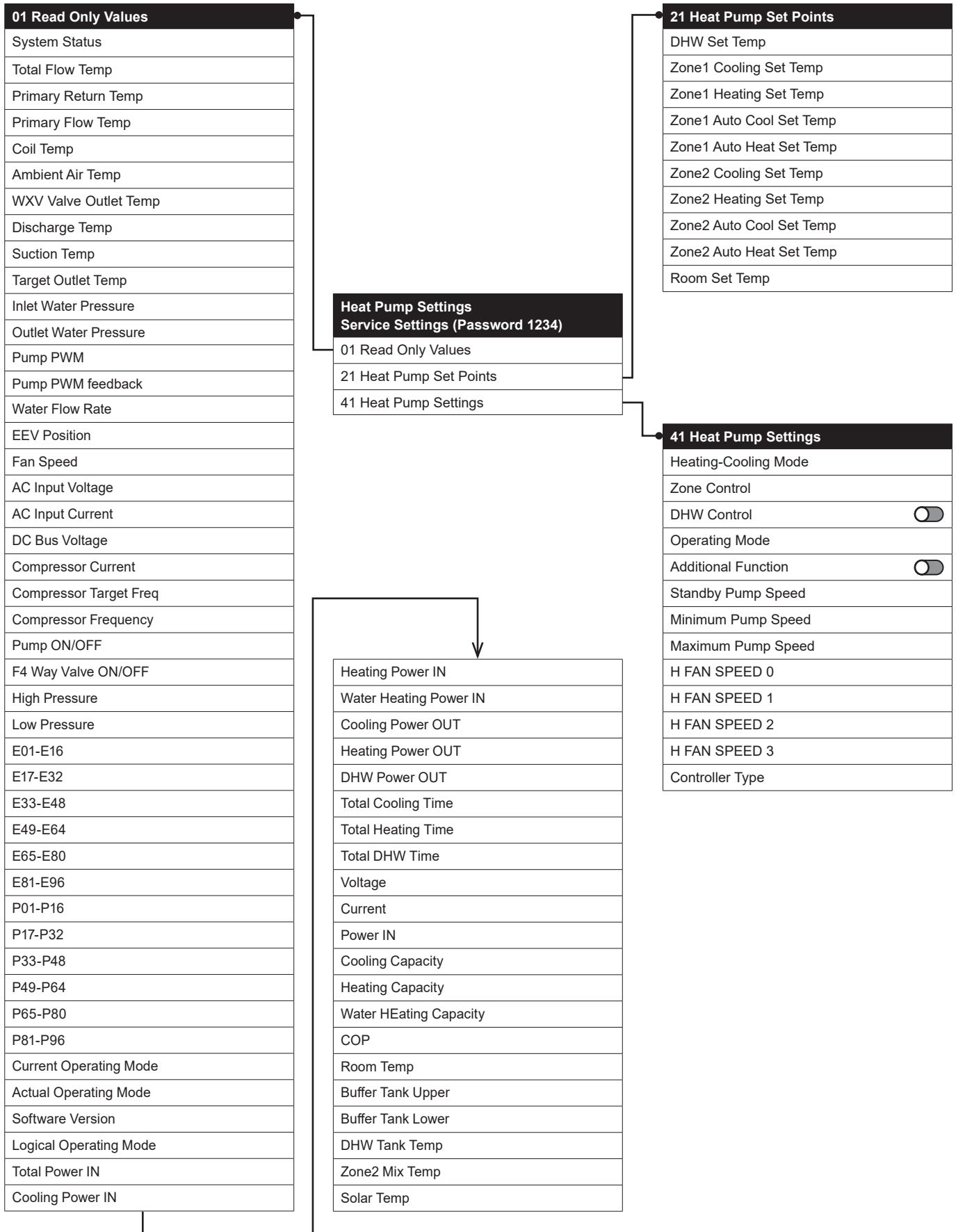

Figure 9-1: Heat pump parameters menu

# 10 WI-FI HUB

## 10.1 GENERAL

The Wi-Fi hub enables the Smart Controller to be accessed and operated remotely via the Internet or app. Users can monitor the operation of the Smart controller and modify some operation parameters with the use of a computer, Tablet or mobile phone. Essential features of the module include:

- Communication with econet24.com external server provides access to Smart Controller via Internet.
- Support Wi-Fi wireless network access.
- Preview of the current operation parameters of the Smart Controller in readable and clear “tiles”.
- Visual diagrams indicating current operation of the installed hydraulic system.
- Preview and edit options of most user and service parameters of the controller.
- Registration of operation parameters and alarm conditions of the controller.
- E-mail notifications of alarm conditions of the main controller.

The mobile app is available from Google play or IOS store and can be downloaded using the QR codes below.



ecoNET.apk (Android)



ecoNET.app (IOS)

## 10.2 CONNECTION TO WIRING CENTRE

Connect the supplied Wi-Fi hub power cable from the Micro USB “power” socket of the Wi-Fi hub to the USB A socket on the side of the wiring centre attached to the cylinder. Refer to Figure 10-1 & 10-2.

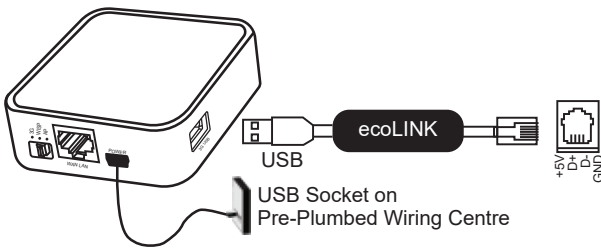

Figure 10-1: ecoLINK Cable connection

The Wi-Fi hub is connected to the wiring centre using the ecoLINK interface cable supplied Smart controller kit. This connection is made from the 3G USB port of the Wi-Fi hub to the socket labelled G3 in the wiring centre.

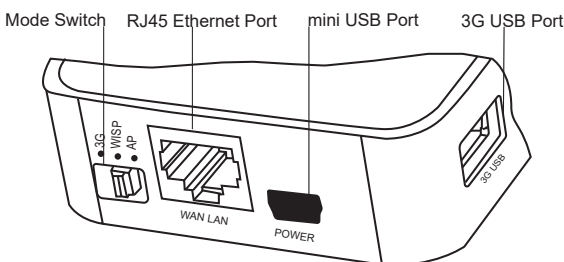

Figure 10-2: Connection ports

The Mode Switch can be set in any position.

A double sided, self adhesive patch is supplied for the Wi-Fi hub to be attached to the electrical housing.

After the power is on, hub requires approx. 1 minute in order to load the operational system. The module will then indicate its condition via the LED. In a connection between hub with a main controller is active, a “ connection with controller” indicator lights up.

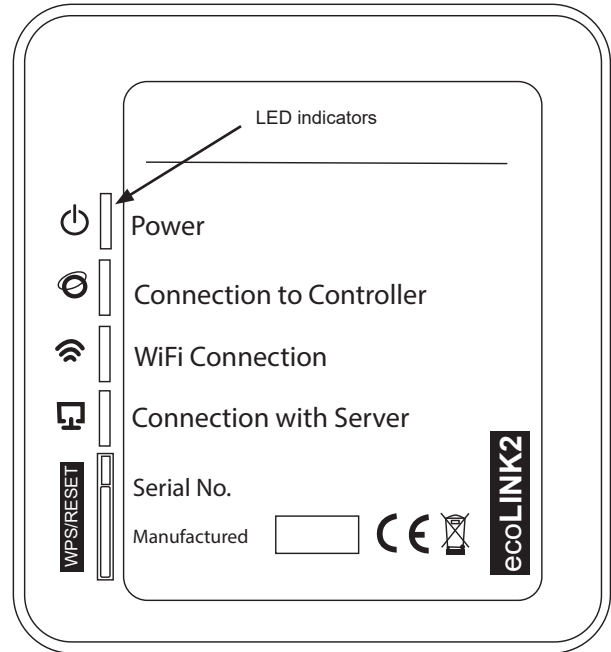

Figure 10-3: Web Module

Table 10-1: LED description

LED	ON/OFF Condition
	Status of Power.
	Active connection to the Smart Controller.
	Connection to Wireless Network
	Connection to ecoNET24 external server

## ! NOTE !

**The Wi-Fi hub requires active DHCP server connection (as is standard with most household routers). Manual IP assignment for the hub is not supported.**

If you should experience any issues during setup or the user forgets their details for logging in the Wi-Fi hub, it is possible to restore default data with the use of the WPS/Reset button on the hub housing.

- Push and hold 'WPS/RESET' for at least 10 seconds.
- Release the 'WPS/RESET' button. LED indicator above should flash several times.
- Wait for approx. 2 minutes.
- The hub will automatically start up and connect with the Internet using default username (**admin**) and password (**admin**).

Wi-Fi access parameters will need to be entered into the touchscreen display via the User settings menu for the hub to be able to make a wireless connection. (Refer to Section 7.9 and 10.3)

### 10.3 CONNECTION TO INTERNET

The supplied Wi-Fi hub will need to be connected to the internet via either an Ethernet cable between a router and the hub or via Wi-Fi.

#### 10.3.1 USE THE ECONET CONFIGURATION WIZARD

The ecoNET configuration wizard is either accessed via the System configuration creator (on first power on) or from the user settings menu (Refer to Section 7.9).

After you have begun the configuration wizard:

1. Tap '>' to confirm to proceed.
2. Follow the steps displayed to connect the Wi-Fi hub to the wiring centre (if this has not already been done) and tap '>' to confirm.
3. The touchscreen display will confirm if the Wi-Fi hub has been successfully connected. Tap '>' to proceed.
4. Select your preferred connection method:
  - Ethernet - Ethernet cable connection between router and Wi-Fi hub.
  - Wi-Fi - Wireless connection between router and Wi-Fi hub.

#### If ethernet selected:

5. Follow the steps displayed to connect the ethernet cable to the Wi-Fi hub (if this has not already been done) and tap '>' to confirm connection.
6. The smart controller will automatically perform a test for connection status to the ecoNET external server. The touchscreen will display confirmation connection once this has been made.

#### If Wi-Fi selected:

5. Fill in required information by tapping boxes to open on-screen keyboard to input.
  - SSID - Name for the Wi-Fi network the hub is required to connect to.
  - Password - Password to access the Wi-Fi network.
  - Type of Security - Wi-Fi security protocol the router uses. WPA 2 is the most commonly utilised.

## ! NOTE !

Take care to tap '<' to confirm input parameters via the on-screen keyboard. To go back tap 'v'

6. Tap 'PERFORM A CONNECTION TEST' to test for connection status to the ecoNET external server. The touchscreen will display confirmation connection once this has been made.

## ! NOTE !

It may take time to authenticate a Wi-Fi connection. Allow time for IP address synchronisation with the router (Up to 5 minutes if first attempt to connect fails).

#### 10.3.2 WI-FI MANUAL CONFIGURATION

To configure Wi-Fi access manually, navigate to the user settings menu and select the Radio Icon (Refer to Section 10.3.3).

1. Tap 'WI-FI SETTING'.
2. Enter the required information by tapping each box to display the on-screen keyboard to input.
  - SSID - Name for the Wi-Fi network the hub is required to connect to.
  - Password - Password to access the Wi-Fi.
  - Type of Security - Wi-Fi security protocol the router uses. WPA 2 is the most commonly utilised.
3. Check connection status if required. Refer to Section 10.3.3.

## ! NOTE !

The wireless router is only compatible with a 2.4GHZ wireless signal.

#### 10.3.3 HOW TO CHECK CONNECTION STATUS

Follow the steps to check the connection status with ecoNET24 services on the touchscreen display.

1. When the heating circuit control interface is shown (see Figure 7-1), tap settings menu. Refer to Table 7-1 and Figure 10-4.

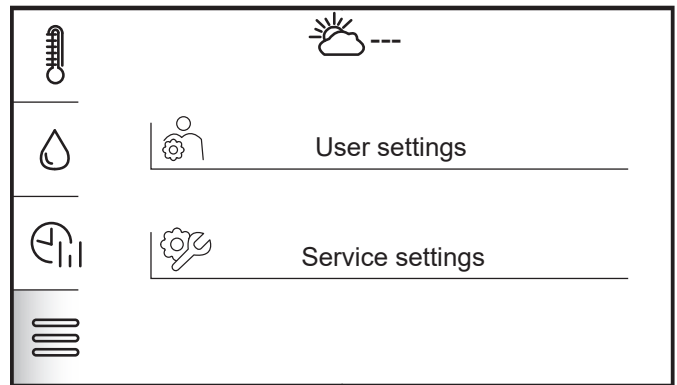

Figure 10-4: Settings selection

2. Tap 'USER SETTINGS'. Refer to Figure 10-5.

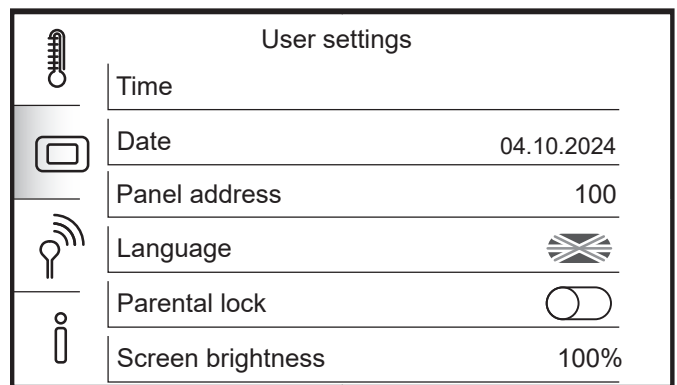

Figure 10-5: User settings menu

3. Tap the Wi-Fi icon on the left. Refer to Figure 10-6.

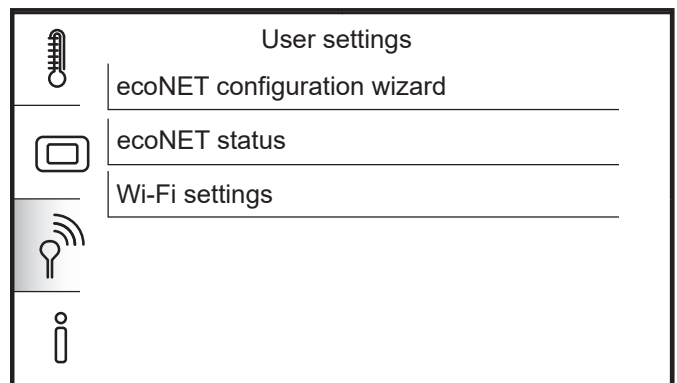

Figure 10-6: ecoNET connection options.

4. Tap 'ECONET STATUS'. Refer to Figure 10-7 for connection status display.

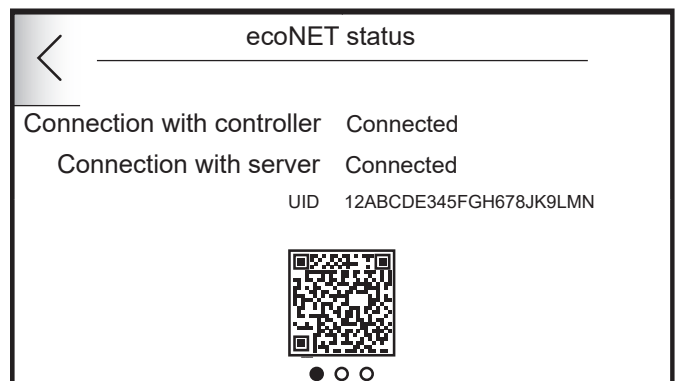

Figure 10-7: ecoNET connection status

# 11 COMMISSIONING, DRAINING DOWN & SAFETY

## ! NOTE !

Commissioning details should be entered in the commissioning and service log at the back of these instructions.

### 11.1 FILLING THE CYLINDER

## ! CAUTION !

Before filling the cylinder check that the immersion heaters have not loosened in transit. Tighten as necessary using a shaped spanner. Stillsons or pipe grips should not be used.

1. Ensure that all connections are fully tightened.
2. Ensure that the service valve in the cold water supply is closed.
3. Open all hot water taps supplied by the cylinder.
4. Slowly open the service valve in the cold water supply.
5. Continue to fill the cylinder until water flows from all taps.
6. Open the service valve fully and close all the hot taps.
7. Allow system to stabilise for five minutes.
8. Open each hot water tap in turn to expel air from the system pipe work.
9. Check for leaks.
10. Manually operate Temperature and Pressure Relief Valve (refer to Figure 2-2), to ensure free water flow through discharge pipe. (Turn knob to left).
11. Heat the water to chosen temperature and then close the service valve.
12. Drain the cylinder to flush out any flux/solder from the installation process. Refer to Section 11.2 below.
13. Re-fill the cylinder – as described above.
14. Re-heat cylinder to the required temperature and re-check for leaks.

### 11.2 DRAINING DOWN

1. Switch off the electrical power to the immersion heater (important to avoid damage to the element).
2. Switch off the heat pump (or boiler).
3. Turn off the cold water service valve (or stop cock).
4. Open all hot water taps.
5. Open drain cock in cold water supply to drain unit down. Refer to Figure 2-2.

### 11.3 IMMERSION HEATER SAFETY CUT-OUT

The immersion heater incorporates an independent non self-resetting over temperature cut-out device to prevent excessive water temperatures. Refer to Section 4.4 for further details.

The safety cut-out will operate if:

- a. The wiring is incorrect.
- b. The immersion heater thermostat or cylinder thermostat fails.
- c. Thermostat is set too high.

To reset the safety cut-out:

1. Unscrew and remove the nut holding the immersion heater cover in place.
2. Remove the immersion heater cover.

## ! WARNING !

Before removing the immersion heater cover, to either reset the safety cut-out or check/alter the thermostat setting, ensure that the electrical supply is isolated.

3. The safety cut-out reset pin is positioned to the side of the control knob (indicated by a triangle with the words 'safety' above). Refer to Figure 11.1.
  4. If the cut-out has operated, the reset pin will be pushed upwards (to be level or slightly above the cover).
  5. Wait until the temperature has fallen sufficiently.
  6. Investigate and identify the cause of the cut-out operation and rectify the fault.
  7. Press in the reset pin (to its normal operating position) to reset the cut-out. Use hand pressure only with a suitably sized implement.
  8. Refit the immersion heater cover correctly and secure in position with retaining nut.
  9. Switch the mains electricity supply back on.
- If the problem persists, please contact your installer.

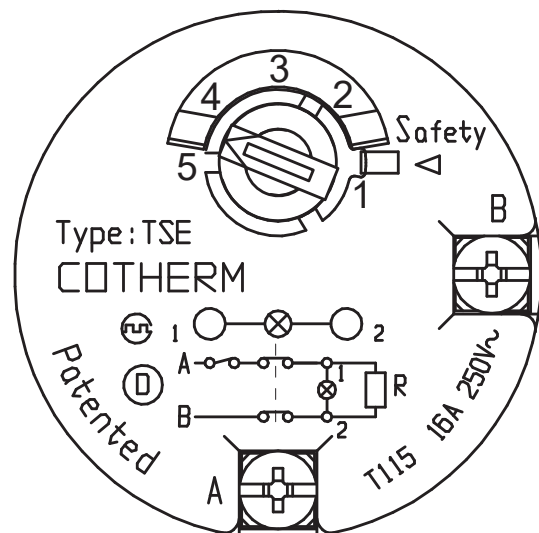

Figure 11-1: TSE single pole thermostat plan view details

#### 11.4 COLD WATER DISCHARGE FROM TUNDISH

There are two reasons why cold water will discharge from the tundish:

1. The pressure reducing valve has malfunctioned (This will cause a large volume of water to flow through the tundish).
2. The Expansion relief valve is letting by (This will cause a very low volume of water to flow through the tundish).

In both cases, identify the defective component and replace. All repairs must be carried out by a competent person.

#### 11.5 HOT WATER DISCHARGE FROM TUNDISH

There are four reasons why hot water will discharge from the tundish:

1. Thermal cut-out has malfunctioned.
2. The control thermostat has malfunctioned.
3. The T & P valve is letting by.
4. The expansion vessel has failed or lost its charge.

In all cases, should a repair be necessary, the work must be carried out by a competent person.

Isolate the cylinder from all electrical supplies before commencing maintenance work.

#### 11.6 EXPANSION VESSEL

1. The expansion vessel is connected into the cold water supply to the cylinder.

### ! NOTE !

**No valve should be fitted between the expansion vessel and the supply pipe.**

2. Ensure that the air charge in the vessel matches the pressure setting shown on the pressure reducing valve.
3. The expansion vessel must be installed even if an accumulator is fitted.
4. The charge of the vessel must be checked at every annual service.

#### 11.7 SMART CONTROLLER

Refer to Section 6 for the system configuration creator and Appendix F for Smart controller commissioning checklist and common circuit parameters.

#### 11.8 PUMP OVER-RUN PROTECTION

The factory-fitted Aeron Smart controller works in conjunction with the Aeron heat pump to ensure there is no dead heading of the circulating pump at the end of:

- Space Heating & DHW demands
- Defrost cycles
- Frost protection cycles

When any of the above functions end and no other demands are to run, the circulating pump will complete any overrun protection built into the heat pump before going into stand-by. (Refer to supplied installation instructions for the heat pump in question for further details)

To accommodate the flow during this time, the Smart Controller will open any configured space heating valves until the circulating pump stops, after which the valves will be closed.

#### 11.9 CUSTOMER HANDOVER

1. Complete the commissioning and service log at the back of these instructions and leave the instructions with the user.
2. Explain the operation of the system to the User, referring to Section 7 of these instructions.
3. In particular, make the user aware of what to do if water is seen to flow from either the T&P Valve or Expansion relief Valve.
4. Refer the user to the Information given in Section 7 of these instructions.

### ! NOTE !

**Leave these Installation, Servicing and User instructions with the user for future reference.**

#### 11.10 HEALTH & SAFETY INFORMATION

For details of the Health and Safety Information for the heat pump, refer to the Health & Safety section of your installation and servicing instructions supplied with your chosen heat pump..

For details of the Health and Safety Information for any other heating appliances being used, refer to the instructions supplied with the appliance.

Under the Consumer Protection Act 1987 and Section 6 of the Health & Safety at Work Act 1974, we are required to provide information on substances hazardous to health (COSHH Regulations 1988).

# 12 SERVICING & MAINTENANCE

## ! NOTE !

Servicing details should be entered in the commissioning and service log in Appendix D at the back of these instructions.

### 12.1 CYLINDER SERVICING AND MAINTENANCE

1. Servicing and maintenance must only be carried out by a competent unvented hot water installer, or by Grant Engineering (UK) Limited authorised personnel.
2. Before any work whatsoever is carried out on the installation, it MUST first be isolated from the electricity supply.

## ! WARNING !

Both the primary and secondary systems will contain very hot water that will scald; therefore care should be taken when opening any joints, seals or valves.

3. Only use spare parts authorised by Grant Engineering (UK) Limited. The use of unauthorised spare parts will invalidate the guarantee.
4. Drain the cylinder – When draining the cylinder, always switch off the boiler/heat pump and the immersion heater first. Turn off the water supply at the service valve or mains stopcock.  
Connect a hose pipe to the drain cock (see Figure 2-2) and route it to a convenient gully. Open the drain cock and all hot taps that are served by the cylinder. The cylinder may take several minutes to empty completely.
5. In hard water areas it may be necessary from time to time to remove and de-scale the immersion heater element. Replace the gasket each time it is removed.
6. Check any in-line strainers which may be fitted in the cold supply to the cylinder and clean if necessary.
7. Remove the expansion relief valve. Check and clean valve seat. Replace valve. Refer to Section 12.3 for further information.
8. Check the charge pressure in the expansion vessel and top up as necessary. The charge pressure should be 3.0 bar. Refer to Section 12.4 for further information.
9. Whilst the hose pipe is connected, the drain cock open and with the immersion heater removed, the cylinder may be flushed out to remove any debris, sand or lime scale particles that may have collected in the bottom by using a further hose pipe connected to the cold water main.

## ! NOTE !

For inspection access use the immersion heater boss after removing the immersion heater.

10. Close the drain cock, disconnect the hose, refit the immersion heater and close all hot water taps before re-opening the stopcock. Allow the cylinder time to fill whilst checking for any leaks. Release any air from the system by opening each hot water tap individually, starting with the one furthest from the cylinder.
11. Manually lift the expansion relief and temperature and pressure relief valve one at a time, every 12 months (more frequently in hard water areas) to prevent debris from building up behind the valve seat. Whilst carrying out this operation, check that the discharge to waste is unobstructed. Check that each valve seals correctly when released. As the valves are pre-calibrated, they require no further maintenance.

12. Finally switch on the mains electricity supply to the immersion heater and the boiler/heat pump. As the system heats up, check again for any leaks and rectify as necessary.

### 12.2 INLET MANIFOLD ASSEMBLY

The inlet manifold assembly should not, under normal circumstance, require any maintenance. During annual servicing it may be necessary to inspect and/or clean the expansion relief valve. The frequency of cleaning will depend on the local water conditions. Refer to Section 12.3.

### 12.3 EXPANSION RELIEF VALVE

1. Isolate the cold water supply.
2. Remove the un-sprung circlip retaining the expansion relief valve in the inlet manifold body. See Figure 3-1.
3. Carefully remove the expansion relief valve from the inlet manifold body. It is a push fit type fitting, so gently pull on the body of the expansion relief valve until it is released.
4. Clean valve seat face and seating - do not scratch or damage either seat face or seating.
5. Refit in reverse order.
6. Ensure that the circlip is fully inserted into its seat.
7. Expansion relief valve (Grant UK product code: GCS34X)

## ! CAUTION !

Upon re-fitting the circlip used to retain the push-fit expansion relief valve into the inlet manifold body, ensure the circlip is fully inserted into its seat.

### 12.4 EXPANSION VESSEL

1. Isolate the cold water supply.
2. Open hot water taps.
3. Drain cylinder to below the expansion vessel connection.
4. Check expansion vessel air charge.
5. Replace expansion vessel if necessary.
6. Close drain off cock and turn on cold water supply.
7. Refill cylinder whilst checking for leaks.
8. When water is flowing freely from taps close taps.

### 12.5 CONTROLLER MAINTENANCE

#### 12.5.1 WIRING CENTRE MAIN FUSE

The main fuse is located under the wiring centre cover, next to the terminals on the high-voltage side. This is a 250V 5 x 20mm 6.3A 'T' type AC fuse. A spare fuse is located under the cover of the wiring centre on the low-voltage terminals side.

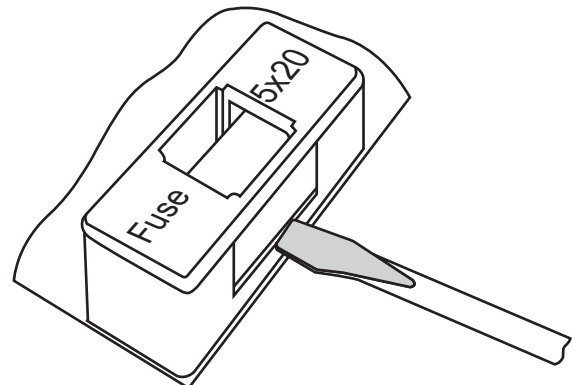

Figure 12-1 Mains fuse replacement

In order to remove fuse lift fuse holder with flat-blade screwdriver and pull out the fuse. Refer to Figure 12-1.

### 12.5.2 TOUCHSCREEN DISPLAY REPLACEMENT

When replacing the touchscreen display make sure that its software is compatible with software in the wiring centre. The compatibility is kept if the first number of software in the touchscreen display and wiring centre are the same.

### 12.5.3 WIRING CENTRE REPLACEMENT

Requirements are analogous to the control panel.

### 12.6 UPDATING CONTROLLER FIRMWARE

Firmware updates can be performed using only microSD HC memory card (max. 32 GB, FAT32 file format).

The memory card should contain new firmware in \*.pfc format for the control panel and \*.pfi format for the controller module. New firmware should be placed directly on memory card with no folders or sub-folders.

## ! NOTE !

**Before starting firmware updates, all peripheral devices operating with the Smart Controller must be disconnected from electric power supply.**

In order to update firmware:

1. Insert memory card into the indicated socket on the touchscreen display. Refer to Figure 12-2.

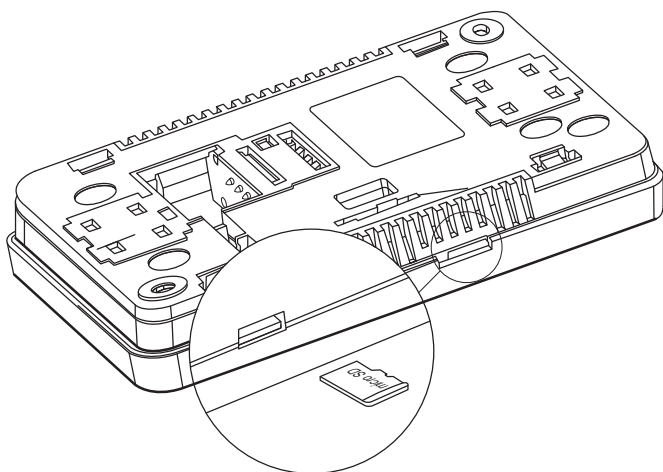

Figure 12-2 Memory card slot

## ! CAUTION !

**Incompatibility of software between the touchscreen display and wiring centre may cause unexpected errors. The manufacturer is not responsible for malfunctions caused as a result of using incompatible software by the end-user.**

2. Reconnect the electric power supply to the controller and turn on.
3. Tap settings menu. Refer to Table 7-1 and Figure 12-3.

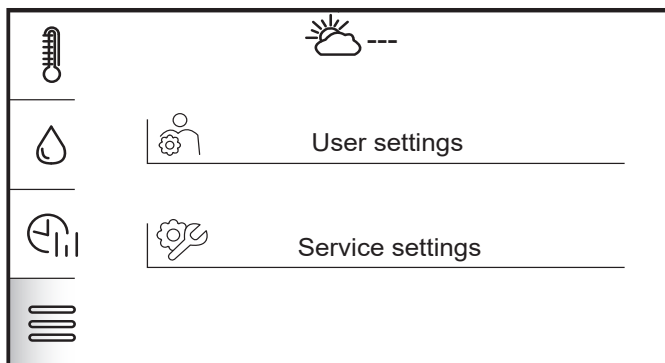

Figure 12-3: User Settings

4. Then tap the User settings. Refer to Figure 12-4.

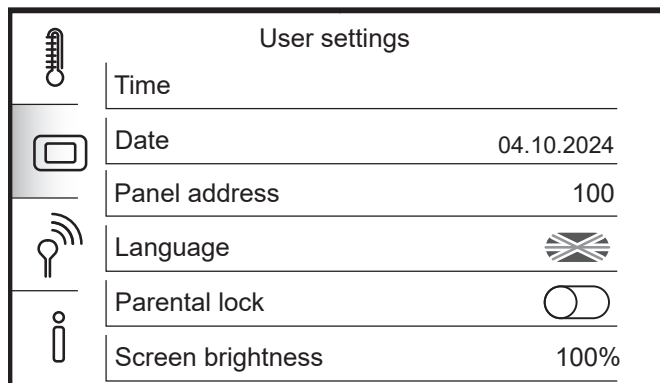

Figure 12-4: User settings menu

5. Tap the information icon at the bottom. Refer to Figure 12-5.

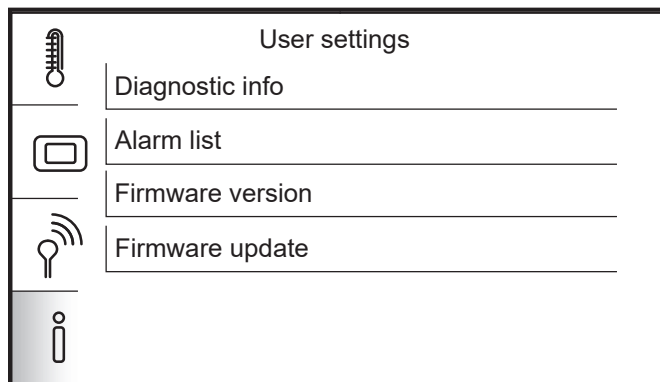

Figure 12-5: Controller information options.

6. Tap 'FIRMWARE UPDATE'.
7. Tap 'CONTROLLER'.

## ! NOTE !

**We recommend the controller be updated prior to the touchscreen display.**

8. The screen will display the versions of software that are both installed (Current) and on the SD card (New) with a prompt at the bottom to 'INSTALL NEW PROGRAM'. Tap the Green '✓' to install.
9. Once the controller software is updated a prompt is displayed. Confirm by tapping '✓' and the controller will restart.
10. Follow steps 3-6 and then tap 'PANEL'. Step 8 will be repeated and once confirmed the controller will update and automatically restart.
11. On completion, the touchscreen display will confirm the update is complete and to remove the SD card. Once removed tap '✓' and the Smart Controller will start.
12. After any software update, we advise the controller be factory reset.
13. Tap settings menu. Refer to Table 7-1 and Figure 11-3.
14. Tap 'SERVICE SETTINGS' and enter the password "7586" and then enter to confirm.
15. Tap "RESTORE DEFAULT SETTINGS" and confirm by tapping '✓'.
16. When confirmation message is displayed, power off the wiring centre with the rocker switch on the side.
17. Wait apx. 10 seconds and then power the wiring centre on.

### 12.7 CONVERTING TO AERONA<sup>3</sup>

The Grant QR2 Smart pre-plumbed cylinder comes preinstalled with software for Grant Aerona R290 heat pumps. A compatible SD card with the firmware to convert the Smart controller to operate with the Grant Aerona<sup>3</sup> heat pump is supplied.

Following the steps described in Section 12.6 will overwrite the existing R290 firmware. Refer to Appendix G for further information on using the Grant QR2 Smart pre-plumbed cylinder with the Grant Aerona<sup>3</sup> heat pump range

# 13 SPARE PARTS & ACCESSORIES

## 13.1 SPARE PARTS

**Table 13-1:** Grant QR2 Smart Pre-plumbed indirect HP cylinders - spare parts

Product description	Product code
Inlet manifold c/w 3 bar pressure reducing valve and 6 bar expansion relief valve	GCS07X
Safety/Pressure Relief valve - 6 bar - push fit	GCS34X
½" Temperature and pressure relief valve 90°C / 7 bar - (all models EXCEPT 250L & 300L)	GCS09
¾" Temperature and PRV - 7 bar/90°C - (250L & 300L models only)	GCS17
Tundish - 15mm / 22mm compression - (all models EXCEPT 250L & 300L)	GCS10
Tundish - 22mm / 28mm compression - (250L & 300L models only)	GCS22X
TS00014 immersion heater thermostat only	GCS40
TS00014 immersion heater thermostat only	GCS40
3kW immersion heater element and TS00014 immersion heater thermostat	GCS41
½" Drain cock with ¾" outlet	GCS14X
2-port motorised valve (22mm)	GCS20X
18 litre expansion vessel with 22mm compression fitting (300L models only)	GCS01A
25 litre expansion vessel with 22mm compression fitting (300L models only)	GCS04A
Expansion vessel mounting bracket - All models	GCS03X
Water temperature sensor with 2m cable	HPIDSMARTSEN2
Water temperature sensor with 4m cable	HPIDSMARTSEN4
Outdoor Weather Sensor	HPIDSMARTWSEN
Smart Flow sensor (Aerona <sup>3</sup> only)	HPIDSMARTFLO
Smart Flow sensor cable (with M12 connector)	HPIDSMARTFLOCABLE
Smart Controller Wi-Fi Hub	HPIDSMARTHUB
Smart controller touchscreen display (includes Cable and Backplate)	HPIDSMARTTSD
ecoLINK cable	HPIDSMARTTPLINK
Smart controller wiring centre (includes fixings accessory pack)	HPIDSMARTWCEN

## 13.2 ACCESSORIES

Grant UK offer a variety of thermostat solutions to work in conjunction with the Grant QR2 Smart Pre-plumbed cylinder.

**Table 13-2:** Grant QR2 Smart Pre-plumbed cylinder - Additional items

Product description	Product code
Wireless thermostat receiver	HPIDSMARTRECEIVER
Wireless thermostat (no receiver)	HPIDSMARTWRT
Wireless thermostat (with receiver)	HPIDSMARTWRTR
Wired thermostat	HPIDSMARTHRT

# 14 FAULT FINDING

## 14.1 INTERMITTENT WATER DISCHARGE

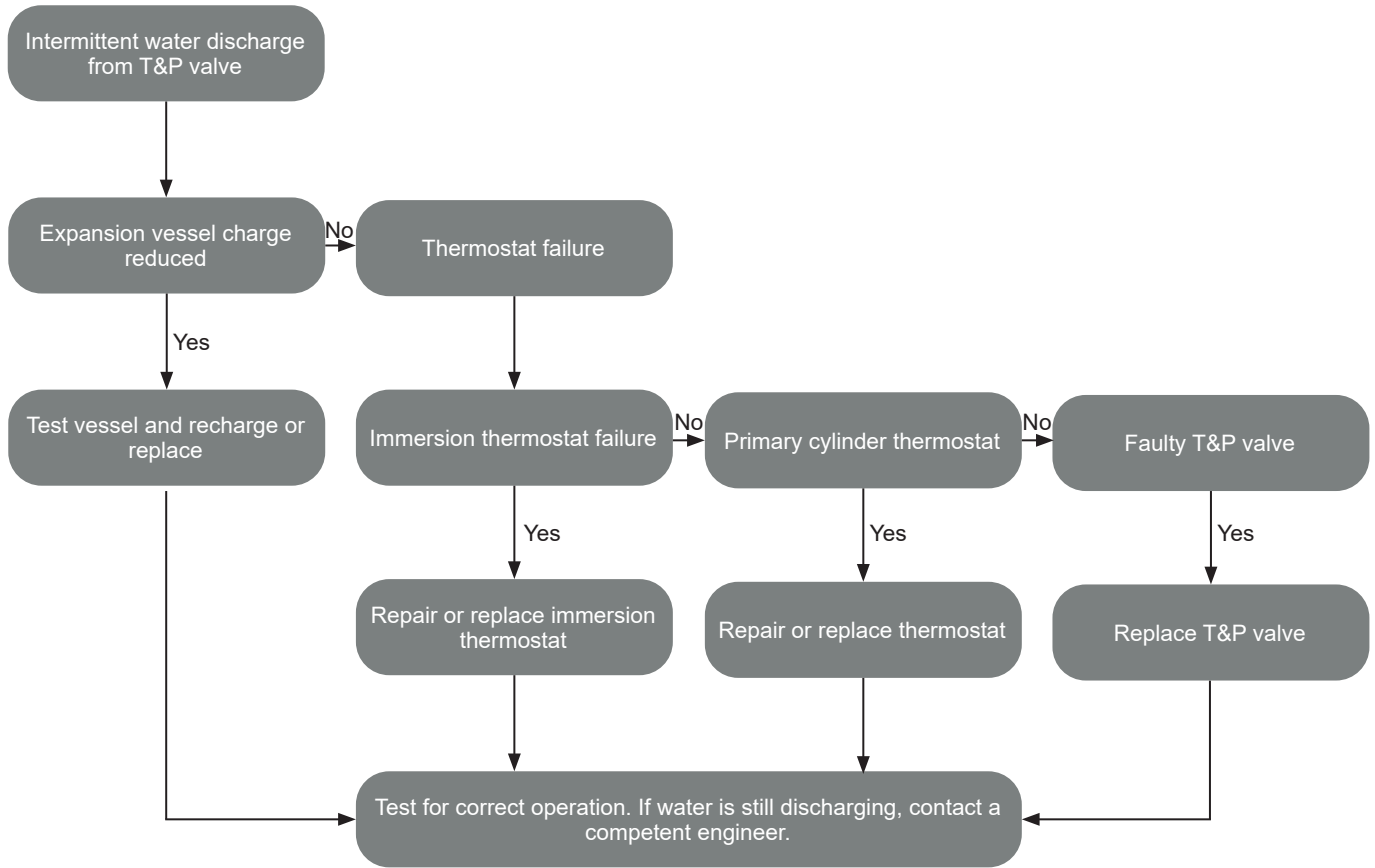

## 14.2 CONSTANT WATER DISCHARGE

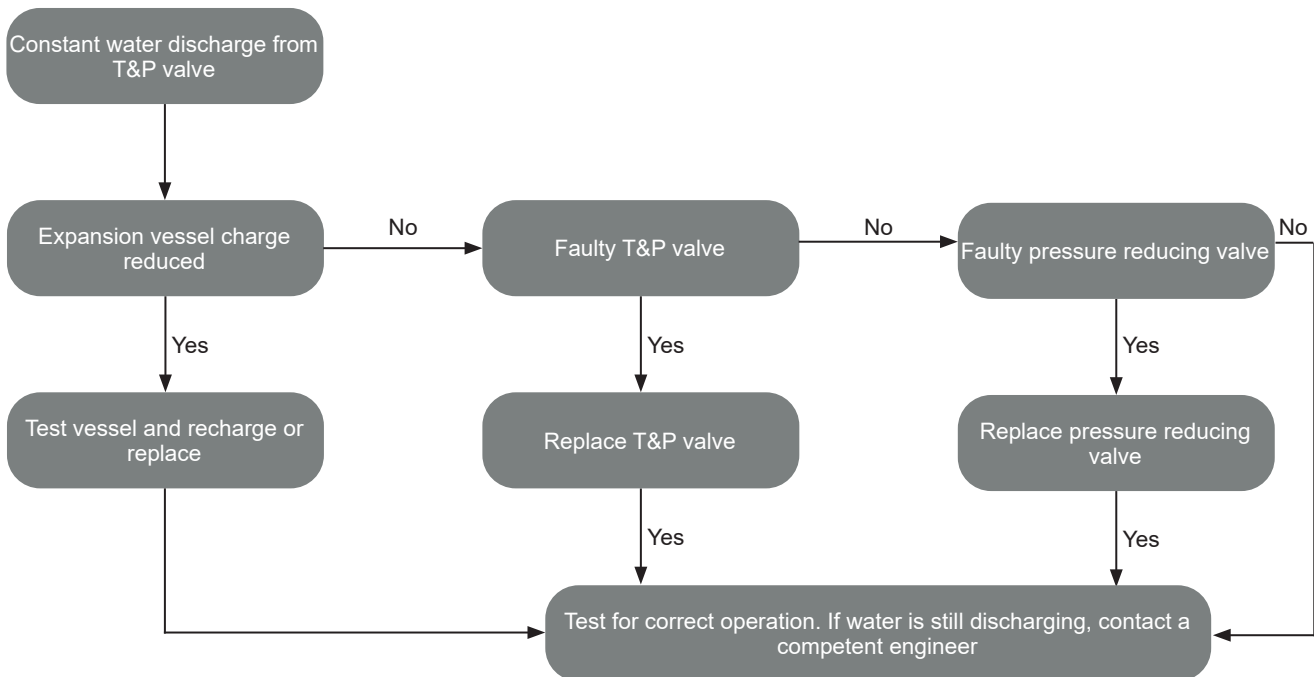

### 14.3 NO FLOW FROM HOT WATER TAPS

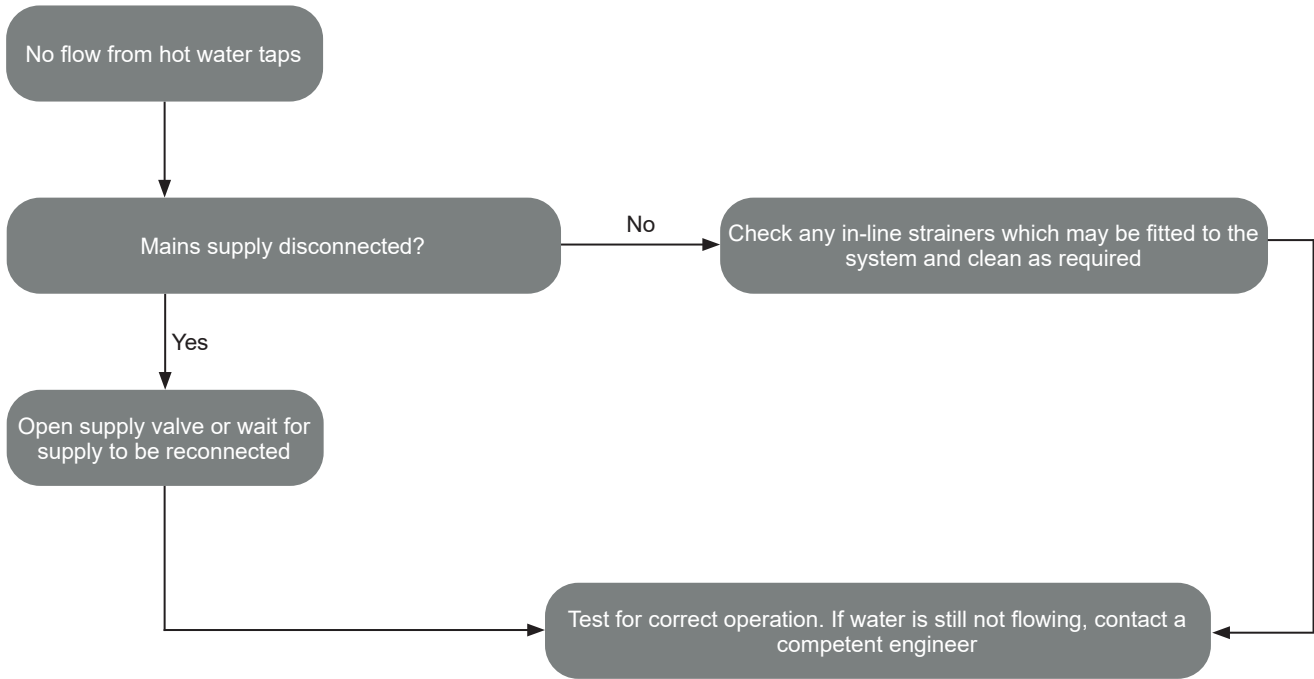

### 14.4 COLD WATER FLOW FROM HOT WATER TAPS

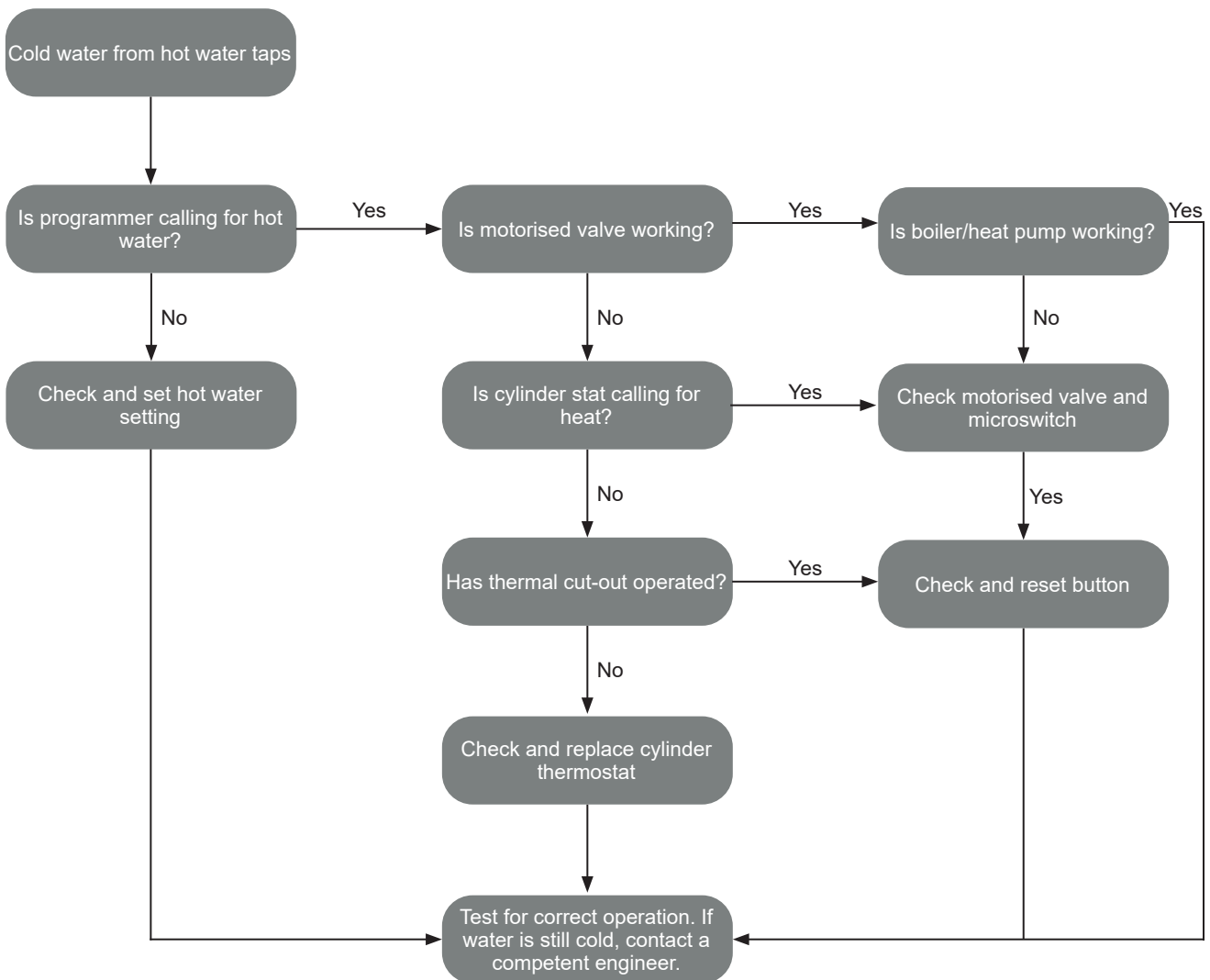

## 14.5 EXCESSIVE HOT WATER FROM TAPS

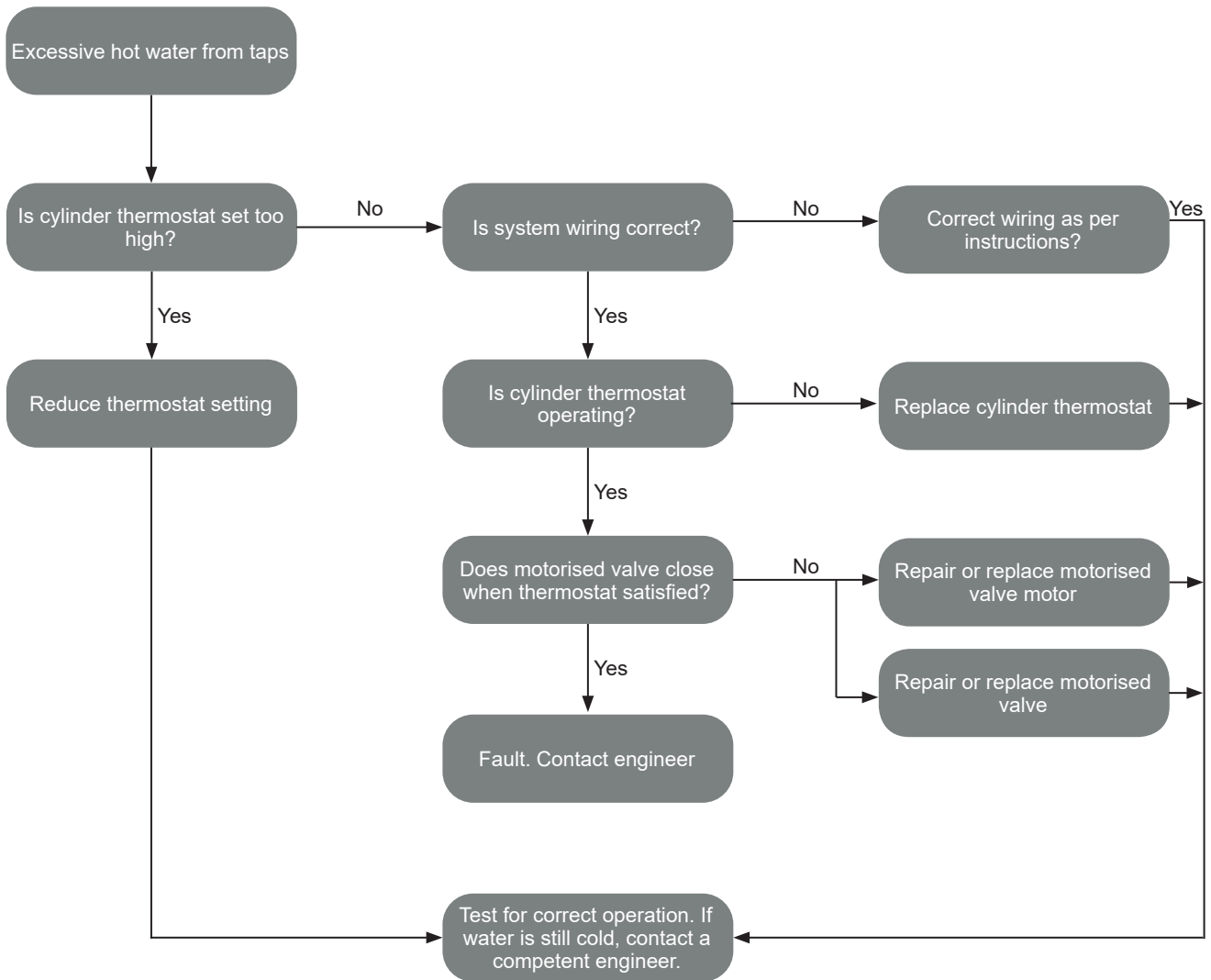

## 14.6 SMART CONTROLLER

Should there be a fault with the smart controller, the heat pump or some of its connected components, the alarm icon will be displayed on the smart controller touchscreen display when viewing a heating or DHW circuit.

Tapping the icon will display a list of the current and historical alerts. Refer to Table 7-1 for more information.

If a wired or wireless thermostat is configured, this will also display an alarm code. Refer to Appendix A & B for thermostat alarm code lists.

### 14.6.1 ALARMS

#### 14.6.1.1 TEMPERATURE SENSOR ERRORS

If the alarm is an error for Circuit (Circuit 2 or 3), outdoor temperature, upper/lower buffer water or DHW cylinder temperature sensor, you should:

- check the temperature sensors are connected correctly to the wiring centre. These will be connected between terminals 38 and 50 of the wiring centre (15V DC). Refer to Section 4.14 for wiring centre schematic.
- check for loose connections on the sensors and wiring centre terminals.
- check the sensors have been installed correctly and are not damaged.
- check the sensors have been installed as per the system scheme. (e.g., Outdoor temperature sensor has been configured but not installed as the heat pump was intended to be used).

#### 14.6.1.2 NO CONNECTION TO HEAT PUMP

If the alarm is 'No communication with the heat pump module', you should:

- check the heat pump had power and the isolator is set to ON.
- check that both the connection and polarity of the wires for the Modbus connection between the wiring centre and the heat pump are correct.

Refer to Section 5.9 for Modbus connection between the heat pump and wiring centre.

#### 14.6.1.3 NO FLOW DETECTED

If the alarm is 'No Flow detected', you should:

- check the Smart flow sensor is connected to the Smart controller wiring centre correctly.
- check the Smart flow sensor is configured correctly on the Smart controller. Refer to Appendix E.
- check the heat pump is working correctly.

### 14.6.2 THERMOSTATS

For issues when attempting to pair or use additional thermostats on the smart controller, you should:

- check that the wired thermostat or wireless receiver has been connected correctly to the G1 socket.
- check the wireless thermostat has been paired. Refer to Appendix B.3.2 and A.1 for thermostat status information from the display.
- check the thermostats are paired to the space heating circuit.
- ensure thermostat addresses are different if multiple wireless thermostats are being used, and you have the correct thermostat for the circuit. Refer to Appendix B.3.2 and B4.

#### 14.6.4 ECONET

The smart controller will give an indication on the touchscreen display of the status of connection with the Econet24 external services via the Econet cloud icon. Refer to Figure and Table 7-1

If the symbol is 'green', the smart controller has an active connection to the ecoNET24 server.

If the symbol is red, the smart controller does not have an active connection to the ecoNET24 server.

The first step will be to check the Wi-Fi hub. The LED indicators on the front will aid in deciphering the issue.

Refer to Table 14-1 for information on LED indicators and how to resolve faults.

Refer to section 10 for further information on the Wi-Fi hub and connection to the wiring centre.

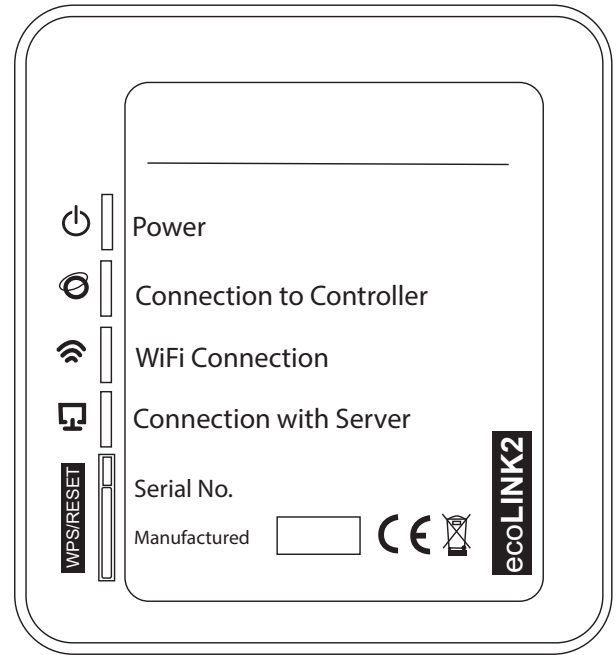





Figure 14-1: Web Module

Table 14-1: LED description

LED Label	Indicator name	Resolution
	Status of Power.	Check Power supply cable is connected to source correctly. Check power supply cable is secure in the Wi-Fi Hub. Check power supply cable is not damaged.
	Active connection to the Aeron Smart Controller.	Check the ecoLINK cable is connected securely in the Wi-Fi hub. Check the ecoLINK cable is connected to the wiring centre correctly. Check the ecoLINK cable is not damaged.
	Connection to Wireless Network	Check the Wi-Fi router is on. Check the Wi-Fi settings on the Smart controller are correct.
	Connection to ecoNET24 external server	Ensure the UID is registered to a ecoNET24 user account. Visit <a href="http://www.econet24.com">www.econet24.com</a> to register. <b>Refer to Appendix H for more information on ecoNET24.</b>

# 15 PRODUCT FICHE

Product fiche concerning the  
THE ECODESIGN FOR ENERGY-RELATED  
PRODUCTS AND ENERGY INFORMATION  
(AMENDMENT) (EU EXIT) REGULATIONS 2020

Model	Description	Energy efficiency	Standing Loss (W)	Actual Volume (litres)
QR2SMART180PP	180 litre Single Coil Pre Plumbed	B	1.21	167
QR2SMART210PP	210 litre Single Coil Pre Plumbed	B	1.41	197
QR2SMART250PP	250 litre Single Coil Pre Plumbed	B	1.54	237
QR2SMART310PP	300 litre Single Coil Pre Plumbed	C	1.81	289

# 16 END OF LIFE

## 16.1 GENERAL

Grant hot water storage cylinders and thermal stores incorporate components manufactured from a variety of different materials. The majority of these materials can be recycled whilst the smaller remainder cannot.

Materials that cannot be recycled must be disposed of according to local regulations using appropriate waste collection and/or disposal services.

## 16.2 DISASSEMBLY

There is little risk to those involved in the disassembly of the cylinder or thermal store if the process is undertaken with care and reasonable precautions are taken.

## 16.3 RECYCLING

Many of the materials used in Grant hot water storage cylinders and thermal stores can be recycled, as listed below:

### COMPONENT

Shell

Internal coils

Bosses

Compression connections

Outer casing

Top/bottom caps

T&P valve

Immersion heater

Insulation

### MATERIAL

Stainless steel (Duplex 2304)

Stainless steel

Stainless steel (316L)

Brass

Galvanised steel with polyester and polyethylene terephthalate (PET) coating

ABS

Brass

Brass/stainless steel

Polyurethane foam; 50mm around and 75mm for top section

## 16.4 DISPOSAL

All materials other than those listed above must be disposed of responsibly as general waste.



Neil Sawers

Technical Manager

## 16.5 DIRECTIVE WEEE 2012/19/EU

Purchased product is designed and made of materials of the highest quality.

The product meets the requirements of the Directive 2012/19/EU of 4 July 2012 on waste electrical and electronic equipment (WEEE), according to which it is marked by the symbol of crossed-out wheeled bin (like below), meaning that product is subjected to separate collection.

Responsibilities after finishing a period of using product:

- Dispose of the packaging and product at the end of their period of use in an appropriate recycling facility,
- Do not dispose of the product with other unsorted waste,
- Do not burn the product.
- By complying with the above obligations of controlled disposal of waste electrical and electronic equipment, you avoid harmful impact on the natural environment and threats to human health.

# 17 DECLARATION OF CONFORMITY

## DECLARATION OF CONFORMITY

QR CODE	Description
	<p><b>Grant QR2 Smart pre-plumbed cylinder - Declaration of conformity.</b></p> <p>Follow the QR link to the Grant UK website to view or download the Declaration of conformity and other related documents.</p> <p>For further information or queries please contact <a href="mailto:into@grantuk.com">into@grantuk.com</a> or your local sales representative.</p>

# 18 GUARANTEE

You are now the proud owner of a Smart cylinder from Grant Engineering (UK) Limited, which has been designed to give you years of reliable, trouble free operation. The product consists of a cylinder and a Aerona Smart Controller for use with the Grant Aerona Air Source Heat Pump range.

Grant Engineering (UK) Limited guarantees the manufacture of the Smart cylinder including all electrical and mechanical components for a period of **twelve months from the date of installation**<sup>4</sup>, provided that the cylinder, Smart controller and air source heat pump with which it is being used have been installed in full accordance with the installation and operating instructions issued.

This will be extended to a total period of **two years** if the cylinder is registered with Grant Engineering (UK) Limited **within thirty days of installation**<sup>4</sup> and is serviced at twelve monthly intervals<sup>3</sup>. See main Terms and Conditions below.

In addition, the stainless steel (shell) used in the manufacture of the cylinder is guaranteed for a period of **twenty five years** from the date of installation<sup>4</sup>.

## Registering the product with Grant Engineering (UK) Limited

Please register your cylinder with Grant Engineering UK Limited **within thirty days of installation**. To do so visit [www.grantuk.com](http://www.grantuk.com) and follow the links to the 'Homeowners Zone', where you can register your cylinder for a further **twelve months** guarantee (giving **two years** from the date of installation<sup>4</sup>). This does not affect your statutory rights<sup>1</sup>.

## If a fault or defect occurs within the manufacturer's guarantee period

If your Smart cylinder should fail within the guarantee period, you must contact Grant Engineering (UK) Limited who will arrange for the repair under the terms of the guarantee, providing that the cylinder, Smart controller and heat pump with which it is being used have been correctly installed, commissioned and serviced (if the appliance has been installed for more than twelve months) by a competent person and the fault is not due to tampering, misuse or the failure of any external components not supplied by Grant Engineering (UK) Limited, e.g. pipework, etc.

**This two-year guarantee only applies if the Smart cylinder is registered with Grant Engineering (UK) Limited within thirty days of installation<sup>4</sup> and is checked along with the associated valves, sensors, etc. when the heat pump is serviced after twelve months<sup>3</sup>.**

## In the first instance

Contact your installer or commissioning engineer to ensure that the fault does not lie with the system components or any incorrect setting of the system controls that falls outside of the manufacturer's guarantee otherwise a service charge could result. Grant Engineering (UK) Limited will not be liable for any charges arising from this process.

## If a fault covered by the manufacturer's guarantee is found

Ask your installer to contact Grant Engineering (UK) Limited Service Department on +44 (0)1380 736920 who will arrange for a competent service engineer to rectify the fault.

## Remember - before you contact Grant Engineering (UK) Limited:

- Ensure the cylinder has been installed, commissioned and serviced by a competent person in accordance with the installation and servicing instructions.
- Ensure the problem is not being caused by the heating system, its controls or any system connected to it.

## Free of charge repairs

During the **two year** guarantee period no charge for parts or labour will be made, provided that the cylinder has been installed and commissioned correctly in accordance with the manufacturer's installation and servicing instructions, it was registered with Grant Engineering (UK) Limited within thirty days of installation and<sup>4</sup>, for cylinders over twelve months old, details of annual service is available<sup>3</sup>.

The following documents must be made available to Grant Engineering (UK) Limited on request:

- Proof of purchase
- Benchmark 'Installation, Commissioning and Service Record Log Book
- Service documents
- System Design Criteria

## Chargeable repairs

A charge may be made (if necessary following testing of parts) if the cause of the breakdown is due to any fault(s) caused by the plumbing or heating system, e.g. contamination of parts due to system contamination, sludge, scale, debris or trapped air. See 'Extent of manufacturer's guarantee' below.

## Extent of the manufacturer's guarantee:

The manufacturer's guarantee does not cover the following:

- If the Smart cylinder has been installed for over **two years**
- If the Smart cylinder and/or the air source heat pump with which it is being used have not been installed, commissioned, or serviced by a competent person in accordance with the installation and servicing instructions.
- The serial number has been removed or made illegible.
- Fault(s) due to accidental damage, tampering, unauthorised adjustment, neglect, misuse or operating the Smart cylinder cylinder and/or the air source heat pump contrary to the manufacturer's installation and servicing instructions.
- Damage due to external causes such as bad weather conditions (flood, storms, lightning, frost, snow or ice), fire, explosion, accident or theft.
- Fault(s) due to incorrectly sized expansion vessel(s), incorrect vessel charge pressure or inadequate expansion on the system.
- Fault(s) caused by external electrics and external components not supplied by Grant Engineering (UK) Limited.
- Smart Cylinder and/or heat pump servicing, de-scaling or flushing.
- Checking and replenishing system pressure.
- Pipework, electrical cables and plugs and external controls not supplied by Grant Engineering (UK) Limited.
- Heating system components, such as radiators, pipes, fittings, electrical cables and plugs, external controls, pumps and valves not supplied by Grant Engineering (UK) Limited.
- Instances where the Smart cylinder has been un-installed and re-installed in another location.
- Use of spare parts not authorised by Grant Engineering (UK) Limited.
- Consumable items including, but not limited to, batteries, antifreeze and biocide inhibitor.
- The replacement of batteries in wireless thermostat.
- The cost and provision of any specialist access equipment, or any associated costs, required to inspect, repair, service or replace any units not installed in accordance with these installation instructions, irrespective of whether the heat pump is deemed to be at fault or not.

### Terms of manufacturer's guarantee:

- The Company shall mean Grant Engineering (UK) Limited.
- The Smart cylinder and heat pump with which it is being used must be installed by a competent installer and in full accordance with the relevant Codes of Practice, Regulations and Legislation in force at the time of installation.
- The Smart cylinder and heat pump for which it is being used is guaranteed for **two years** from the date of installation<sup>4</sup>, providing that after twelve months the annual service<sup>3</sup> has been completed and the cylinder registered with the Company within thirty days of the installation<sup>4</sup>. Any work undertaken must be authorised by the Company and carried out by a competent service engineer.
- The stainless steel (shell) used in the manufacture of the cylinder is guaranteed for a period of **twenty five years** (parts only) from the date of installation<sup>4</sup>. This is subject to the following:
  - The cylinder is operated correctly, in accordance with the installation and servicing instructions.
  - Proof is provided that the connecting system/s has been flushed or chemically cleaned where appropriate (refer to BS 7593) and that the required quantity of a suitable corrosion inhibitor added.
  - Proof of annual servicing (including the checking of any expansion vessels and pressure relief valves) must be provided if and when requested by the Company.
- This guarantee does not cover breakdowns caused by incorrect installation, neglect, misuse, accident or failure to operate the cylinder in accordance with the manufacturer's instructions.
- The cylinder is registered with the Company within thirty days of installation<sup>4</sup>. Failure to do so does not affect your statutory rights<sup>1</sup>.
- The balance of the guarantee is transferable providing the installation is serviced prior to the dwelling's new owners taking up residence. Grant Engineering (UK) Limited must be informed of the new owner's details.
- The Company will endeavour to provide prompt service in the unlikely event of a problem occurring, but it cannot be held responsible for any consequences of delay however caused.
- This guarantee applies to Grant Engineering (UK) Limited Smart cylinders purchased and installed on the UK mainland, Isle of Wight, Channel Islands, Isle of Man and Scottish Isles only<sup>2</sup>. Provision of in-guarantee cover elsewhere in the UK is subject to agreement with the Company.
- All claims under this guarantee must be made to the Company prior to any work being undertaken. Invoices for call out/repair work by any third party will not be accepted unless previously authorised by the Company.
- Proof of purchase and date of installation, commissioning and service documents must be provided on request.
- If a replacement Smart cylinder is supplied under the guarantee (due to a manufacturing fault) the product guarantee continues from the installation date of the original Smart cylinder, and **not** from the installation date of the replacement<sup>4</sup>.
- If replacement controller parts are supplied under the guarantee (due to a manufacturing fault) the product guarantee continues from the installation date of the original Smart cylinder, and **not** from the installation date of the replacement<sup>4</sup>.
- The replacement of a cylinder under this guarantee does include any consequential costs.
- The cylinder must be connected to a mains water supply (installations utilising a private water supply are not covered by this guarantee).
- Breakdown/failure due to lime scale will not be covered by this guarantee.
- The cylinder must not be sited in a location where it may be subjected to frost.

### Hard water advice

If you live in a hard water area, protection against scaling in your cylinder must be provided.

You should fit an appropriate scale inhibitor or water softener as any breakdown caused by water scaling is not covered by either the manufacturer's guarantee. Ask your installer for advice.

**IMPORTANT** Grant Engineering (UK) Limited **strongly recommends** that a Grant Mag-One in-line magnetic filter/s (or equivalent<sup>5</sup>) is fitted in the heating system pipework. This should be installed and regularly serviced in accordance with the filter manufacturer's instructions.

### Foot notes:

1. Your statutory rights entitle you to a one year guarantee period only.
2. The UK mainland consists of England, Scotland and Wales only. Please note that for the purposes of this definition, Northern Ireland and Scilly Isles are not considered part of the UK mainland.
3. We recommend that your cylinder is serviced every twelve months (even when the guarantee has expired) to prolong the lifespan and ensure it is operating safely and efficiently.
4. The guarantee period will commence from the date of installation, unless the installation date is more than six months from the date of purchase, in which case the guarantee period will commence six months from the date of purchase.
5. As measured by gauss. The Mag One magnetic filter has a Gauss measurement of 12000.

# APPENDIX A - WIRED THERMOSTAT

## A.1 GENERAL

The Grant Wired thermostat is designed to provide individual circuit control via the Grant Aerona Smart Controller.

The thermostat is installed in a suitable location to monitor the circuit, e.g., Ground floor hallway, and is designed to maintain a target temperature.

The thermostat on the backlit LCD display shows information about the circuit temperature value, selected operating mode, current time with simultaneous clock synchronization with the main controller.

## A.2 INSTALLATION

The thermostat is intended for installation only in a dry, habitable location and should be mounted to the wall. After choosing the place of installation, make sure that:

- The selected location is free of excessive humidity and the ambient temperature of the thermostat should be within the range of 0 to 40°C,
- The chosen location should ensure free air circulation and should be located away from heat-emitting sources, e.g., electronic equipment, fireplace, heater and direct sunlight.
- The thermostat should be mounted at a height enabling convenient operation, typically 1.5m above the floor. (Refer to Figure 5-1)

The thermostat should be screwed to the wall with mounting screws. Access to the screw holes is obtained by opening and removing the back cover of the thermostat. A flat screwdriver can be used to open the cover.

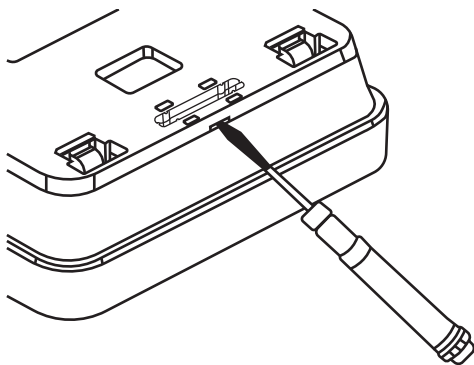

Figure A-1: Wired thermostat back access

The cover is screwed to the selected location of the wall with the appropriate position (UP), as shown in the Figure below. The hole spacing can be determined by attaching the cover to the wall.

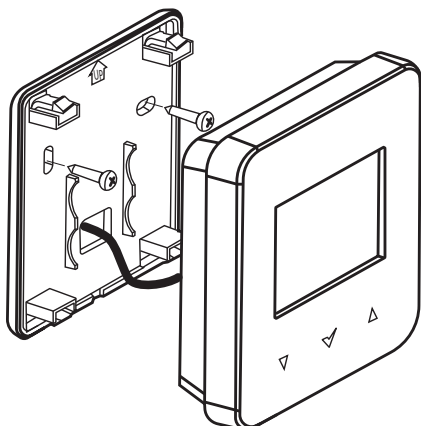

Figure A-2: Wired thermostat wall fixing

Before reattaching the cover, lead the wire connecting the thermostat with the wiring centre through the hole. The cable must be recessed into the wall. The cable can not be routed together with the electrical cables of the building. The cable should not run in the vicinity of devices emitting strong electromagnetic fields.

Then attach the thermostat to the mounting frame using the clips. The VCC, GND, D+, D- terminals of the thermostat should be connected to the G1 socket of the main controller. Refer to Figure A-3.

## ! NOTE !

A 4-core cable with a cross-Section of min. 0.5 mm<sup>2</sup>.

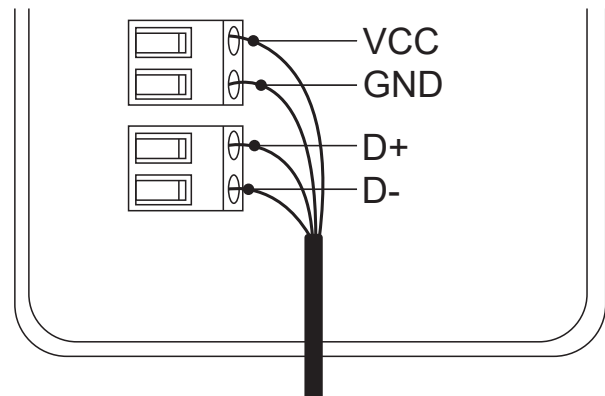

Figure A-3: Wired Thermostat Wiring

## ! NOTE !

Close attention must be paid to the 4 connections for Voltage, Ground and Polarity. Ensure they match to corresponding wires from touchscreen panel

## A.3 THERMOSTAT PANEL

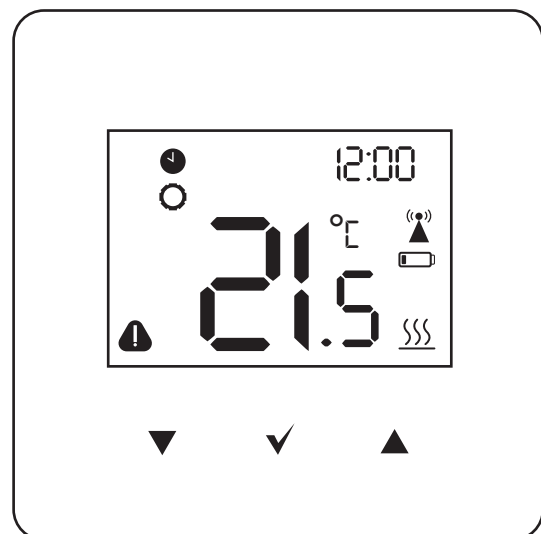











Figure A-4: Wired (& Wireless) thermostat panel LCD

**Table A-1: Wired (& Wireless) thermostat LCD symbols**

Symbol	Symbol description
	Alarm symbol
	Schedule - Thermostat is schedule managed
	Parameter editing
	Heat demand
	Radio signal (Wireless Thermostat only)
	Low battery indicator (Wireless Thermostat only)
	Decrease parameter
	Confirm
	Increase parameter

#### A.4 PAIRING

The wired thermostat should be connected as part of the Smart Controller configuration creator for the circuit that the thermostat will measure. To pair again you can follow this within the individual circuit settings to re-pair to the Grant Aeron Smart controller.

- Access the circuit you wish to pair with a wired thermostat panel from the Circuit settings within the System settings menu (Refer to Section 8) and select the Thermostat option from the menu and confirm you wish to overwrite if a thermostat is already present on the circuit.
- The pairing wizard will begin and will instruct you to set put the desired wired thermostat into pairing mode.
- Follow the on-screen prompts. Hold the up and down buttons simultaneously for 2 seconds. The screen will change to display you have entered the user menu where you then select parameter '03' in the user menu of the thermostat. 'PAR' will be displayed on the screen. When confirmed with the '✓' button, the pairing function will start (the word 'PAR' begins to flash).
- Tap '>' on the touchscreen display.
- Confirmation of the pairing will be confirmed by the message 'END' and 'Succ' on the thermostat.
- After pairing a room thermostat holding the '✓' down will return you first to the previous menu and then the back to the main screen in 2 second intervals.

#### A.5 CHANGING SETPOINT TEMPERATURE

Tapping the up or down arrows will prompt the thermostat into the check/editing of target temperature causing the current target saved temperature to flash.

The first tap of the arrow will trigger the edit temperature function but will not change the value. Tapping the arrow again will then change the value either up or down. Tapping the '✓' will confirm, save and exit.

Not confirming a new target with 5 seconds of inactivity will cause the thermostat to exit the editing mode without changing the target temperature.

## ! NOTE !

**Holding the up or down arrows for more than 2 seconds will cause a fast change to the parameter.**

#### A.6 USER MENU

The user menu is entered by holding simultaneously the and buttons for 2 seconds. Individual parameters of the user menu are visible as consecutive indications displayed on the main screen as described in the table below.

Depending on the controller series, some operating modes and parameters in the user menu may not be visible and some options not applicable to the Aeron Smart Controller as indicated in table below.

The parameters are selected using the up or down buttons and the tick button is confirmed by the selection.

**Table A-2: Thermostat menu**

Code	Alert description
P01-P02	Not used/Reserved
P03	Pairing
P04-P14	Not used/Reserved
P15	Activate/Deactivate Key sounds.
P16	Activate/Deactivate Alarm sounding. <i>Turning OFF will only display alarm symbol on LCD screen.</i>
P17	Activate/Deactivate Alarm sounding OFF between 22.00 and 06.00.
P18	Adjust Screen contrast. (%)
P19	Adjust LCD screen backlight. (%)
P20	Not used/Reserved
P21	Activate/Deactivate parental lock.
P31	Thermostat program version.
P32	Thermostat temperature correction (°C)
P34	Restore factory settings
P35	Thermostat address.
P40	Activate/Deactivate Fuel level indicator
P41	Activate/Deactivate outdoor temperature indication.
P42	Show/Hide display on clock screen.
P50	Temperature floor sensor

## A.7 ERROR CODES

The Smart controller communicates alerts to the thermostat when present in the system. Refer to Table A-3 for determining the fault of a wired thermostat display.

**Table A-3:** Thermostat alarm codes

Code	Alert description
01	No communication with the controller
02	No compatibility of programs
03	Panel temperature sensor error
04	DHW sensor error
05	Upper buffer temperature sensor error
06	Lower buffer temperature sensor error
07	Circuit 2 temperature sensor error
08	Circuit 3 temperature sensor error
09	Anti-freeze active
11	No communication with the thermostat
12	No communication with thermostat circuit 1
13	No communication with thermostat circuit 2
14	No communication with thermostat circuit 3
15	Alarm from digital input
16	No flow detected
17	Too often no flow detected
19	No communication with heat pump module
20	Circuit 4 temperature sensor error (not used)
21	Circuit 5 temperature sensor error (not used)
22	Circuit 6 temperature sensor error (not used)
23	Circuit 7 temperature sensor error (not used)
24	No communication with thermostat circuit 4 (not used)
25	No communication with thermostat circuit 5 (not used)
26	No communication with thermostat circuit 6 (not used)
27	No communication with thermostat circuit 7 (not used)

## A.8 TECHNICAL DATA

**Table A-4:** Wired Thermostat Technical Data

Technical Data - Wired Thermostat	
Power supply	5 to 12 VDC, 0.2 W directly from the main controller socket, power source max. 15W
Degree of protection	IP 20
Relative humidity	5% to 85% without steam condensation
Storage temperature	-10 °C to +60 °C
Working temperature	0 °C - 40 °C
Display	LCD with backlight
Controlling	Capacitive buttons
Dimensions	87 mm x 87 mm x 27.3 mm
Weight	0.2 kg
The thermostat installation method	ON the wall or free-standing
The radio module installation method	On the wall

# APPENDIX B - WIRELESS THERMOSTAT & RECEIVER

## B.1 GENERAL

The Grant Wireless receiver & thermostat are designed to provide wireless circuit control via the Smart controller.

The thermostat should be installed in a suitable location to monitor the circuit, e.g., First floor hallway, and is designed to maintain a target temperature. By sending a radio signal to the module connected to the wireless receiver.

The thermostat on the backlit LCD display shows information about the circuit temperature value, selected operating mode, current time with simultaneous clock synchronization with the touchscreen display.

## B.2 INSTALLING WIRELESS RECEIVER

### B.2.1 WALL MOUNTING

The wireless receiver should be mounted on a wall near the installation location of the wiring centre. If the radio connection is poor, try placing the wireless receiver in other places. Moving the wireless receiver even by a few centimetres can affect the quality of the connection.

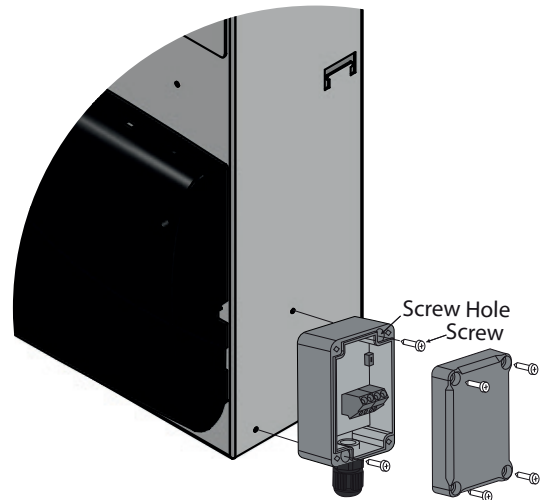

Figure B-2: Wireless receiver mounting

## ! NOTE !

Placing a wireless receiver in a metal casing, e.g. a mounting box, a metal boiler casing, etc. will block the radio signal and thus interfere with the operation.

If wall mounting the radio module, it should be screwed to the wall with the provided fixings. Access to holes for screws is obtained after unscrewing the cover of the module. Refer to Figure B-1.

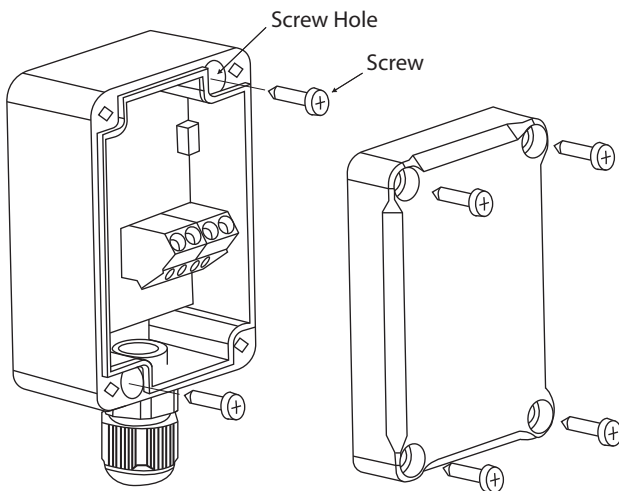

Figure B-1: Wireless receiver wall fixings

### B.2.2 MOUNTING TO CYLINDER

The Grant QR2 Smart pre-plumbed cylinder provides the ability to mount a wireless receiver to the electrical housing of the cylinder via 2 pre-drilled holes to the side. Refer to Figure B-2.

The radio module should be screwed to the electrical housing. Access to holes for screws is obtained after unscrewing the cover of this module. Refer to Figure B-1.

## ! NOTE !

Placing a wireless receiver in a metal casing, e.g. a mounting box, a metal boiler casing, etc. will block the radio signal and thus interfere with the operation.

### B.2.2 WIRELESS RECEIVER WIRING

The terminals D+, D-, GND, 12VDC of the Wireless receiver should be connected to the corresponding terminals in the G1 socket of the wiring centre.

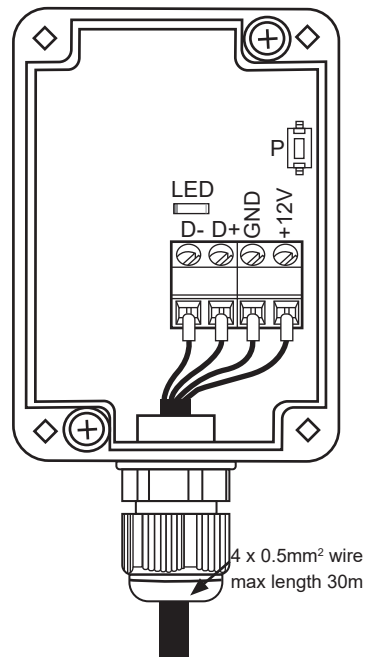

Figure B-2: Wireless receiver wiring

## ! NOTE !

Ensure the correct polarity of the connection of the D+, D- signals and the GND, +12V power supply between the thermostat and the wiring centre. Incorrect connection may lead to damage to the main controller or errors in its operation.

The maximum cable length depends on the cross-section of the wires. For a 0.5 mm<sup>2</sup> wire, it should not exceed 30m. The cross-section should not, however be less than 0.5 mm<sup>2</sup>.

### B.3 WIRELESS THERMOSTAT

The wireless thermostat is intended for installation only in a dry habitable location and should be placed on a flat surface (as a free-standing device) in a room representative for a given heating circuit. After choosing the place of installation, make sure that:

- The selected location is free of excessive humidity and the ambient temperature of the thermostat should be within the range of 5..35°C.
- The chosen location should ensure free air circulation and should be located away from heat-emitting sources, e.g., electronic equipment, fireplace, heater and direct sunlight.
- The selected place must not cause interference or a lack of radio signal.

#### B.3.1 INSERTING OR REPLACING THE BATTERIES

To insert or replace the battery, remove the back cover of the thermostat housing.

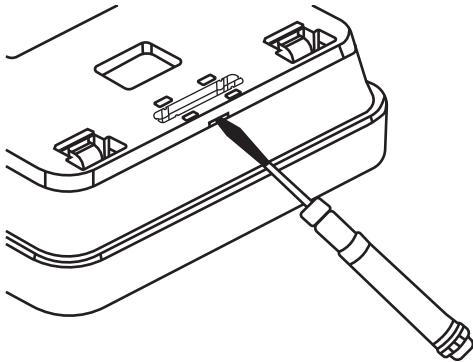

Figure B-3: Wireless Thermostat back access

When inserting the batteries, the battery poles have to be positioned correctly. Check thermostat moulding for guidance.

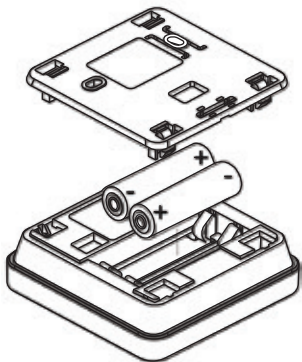

Figure B-4: Battery placement

It is recommended to use alkaline batteries to power the thermostat. The thermostat working time depends on the quality of the batteries used. Refer to Appendix A, Figure A-4 and Table A-1 for low battery indicator symbol.

#### B.3.2 PAIRING A WIRELESS THERMOSTAT WITH THE WIRELESS RECEIVER

A wireless thermostat will need to be paired with the wireless receiver connected to the wiring centre. Follow the steps to access the individual circuit controls and begin the pairing wizard or follow the steps when using the system configuration creator. Refer to Section A4.

- If multiple wireless thermostats are required, the radio address for a second or third will need to be changed prior to pairing to avoid pairing conflicts. Refer to Appendix B.4 for multiple thermostat support.
- Pair all required wireless thermostats in the 1st circuit pairing during system configuration or access the circuit settings of an installed circuit after the system configuration has been completed to save the thermostats to the wireless receiver memory. Refer to Section 6 for System configuration creator & Section 7.3 for heating circuit settings.
- The pairing process for the wireless thermostats is similar to the wired thermostat. Refer to Section A.4.
- After all thermostats are paired, return them to their

respective home screen by holding the '✓' button down for 4 seconds.

- With multiple wireless thermostats paired, you will be given a choice based on the address of the thermostats saved to the memory of the wireless receiver. Select the thermostat you wish to assign to a specific circuit from the displayed list on the touchscreen display.
- For a second or third circuit, confirm already paired thermostats when prompted to pair to access wireless receiver memory for saved thermostat list.

### ! NOTE !

Allow up to 1 minute for connection of thermostats and circuit amends to take effect.

### ! NOTE !

Until the pairing with the wireless receiver is complete, the alarm and radio symbols are permanently displayed on the thermostat screen.

The structural elements of the building, the layout and equipment of rooms, the amount of electronic equipment, the distance between the wireless receiver and the thermostat all affect the quality of the radio signal.

Therefore when choosing a place to install the thermostat, take into account the obtained signal level in the selected location by observing the symbol on thermostat screen. If the symbol:

- is not displayed - Connection has been established  
The symbol is shown only briefly during active radio communication with the wireless receiver.
- flashing - There is no connection or there is a weak signal and you should choose a different place to install the thermostat or add a signal repeater.

### ! NOTE !

The value of the radio signal strength can be read in parameter '30' of the thermostat user menu.

If the radio connection to the thermostat is lost, the Smart Controller will go into an operating mode without a thermostat after a few minutes.

After establishing the radio connection with the thermostat in the touchscreen display Information menu in the Software versions tab, the thermostats will be shown as a Wireless thermostat, with the version of the software displayed.

Connecting the wireless receiver to the wiring centre again does not require pairing if the thermostats have previously been paired.

### B.4 MULTIPLE THERMOSTAT SUPPORT

The wireless receiver can manage up to 3 wireless thermostats. Utilising multiple thermostats with the wireless receiver will require setting an individual address for each thermostat to avoid conflicts in the heating circuits they are assigned to and must be done prior to assigning to a circuit.

To amend the address of an individual thermostat:

1. Hold the up and down buttons simultaneously for 2 seconds. The screen will change to display you have entered the user menu where you then select parameter '35'. The screen will display the currently assigned address ("Ad1" is the default assigned address).
2. Press the '✓'. The current address will flash with the parameter editing symbol. Press Up or down to amend the address and confirm with the '✓'.
3. Holding the '✓' button down will move you back through the user menu to the home screen.

Follow the pairing procedure for a heating circuit as per Section B.3.2 or the on-screen prompts when configuring a circuit. If successful, when you attempt to assign a wireless thermostat to a new circuit, multiple thermostats will be available to choose.

### B.5 THERMOSTAT PANEL

Refer to Appendix A.3 for key thermostat panel information.

### B.6 USER MENU

The user menu is entered by holding simultaneously the up and down arrow buttons for 2 seconds. Individual parameters of the user menu are visible as consecutive indications displayed on the main screen as described in the table below.

Depending on the controller series, some operating modes and parameters in the user menu may not be visible and some options not applicable to the Aerona Smart Controller as indicated in table below.

The parameters are selected using the up or down buttons and the '✓' button is confirmed by the selection.

**Table B-1:** Thermostat menu

Code	Alert description
P01-P02	Not used/Reserved
P03	Pairing
P04-P13	Not used/Reserved
P15	Activate/Deactivate Key sounds.
P16	Activate/Deactivate Alarm sounding. <i>Turning OFF will only display alarm symbol on LCD screen.</i>
P17	Activate/Deactivate Alarm sounding OFF between 22.00 and 06.00.
P18	Adjust Screen contrast. (%)
P19	Adjust LCD screen backlight. (%)
P20	Not used/Reserved
P21	Activate/Deactivate parental lock.
P30	Display active Radio strength from the receiver. (%)
P31	Thermostat program version.
P32	Thermostat temperature correction (°C)
P34	Restore factory settings
P35	Thermostat address.
P41	Activate/Deactivate outdoor temperature indication.
P42	Show/Hide display on clock screen.

### B.7 MEMORY RESET OF THE WIRELESS RECEIVER

To perform a memory reset, hold down the **P** button in the receiver for approximately 8 seconds. The LED will blink after releasing the button confirming the action.

After performing a reset any required thermostats will need to be re-paired.

### B.8 ALARMS

The Smart controller communicates alerts to the thermostat when present in the system. Refer to Table B-2 for determining the fault of a wireless thermostat display.

**Table B-2:** Thermostat alarm codes

Code	Alert description
01	Outside Temperature sensor error
02	No communication with the controller
03	No compatibility of programs
04	Panel temperature sensor error
05	DHW sensor error
06	Upper buffer temperature sensor error
07	Lower buffer temperature sensor error
08	Circuit 2 temperature sensor error
09	Circuit 3 temperature sensor error
11	Anti-freeze active
12	No communication with the thermostat
13	No communication with thermostat circuit 1
14	No communication with thermostat circuit 2
15	No communication with thermostat circuit 3
16	Alarm from digital input
17	No flow detected
19	Too often no flow detected
20	No communication with heat pump module
21	Circuit 4 temperature sensor error (not used)
22	Circuit 5 temperature sensor error (not used)
23	Circuit 6 temperature sensor error (not used)
24	Circuit 7 temperature sensor error (not used)
25	No communication with thermostat circuit 4 (not used)
26	No communication with thermostat circuit 5 (not used)
27	No communication with thermostat circuit 6 (not used)
28	No communication with thermostat circuit 7 (not used)

## B.10 TECHNICAL DATA

**Table B-3: Wireless Thermostat Technical Data**

<b>Grant Aeron Smart Controller - Wiring Centre</b>	
Power supply	2 x AA (LR6) 1.5V - alkaline batteries
Radio module power supply	5 to 12 VDC - directly from the main controller socket
Degree of protection for the thermostat/radio module	IP 20/IP 40
Relative humidity	5 to 85%, without steam condensation
Storage temperature of the thermostat and radio module	-10 °C to 60 °C
Working temperature of the thermostat and radio module	5 °C to 35 °C
Communication	Bi-directional ISM radio communication
The band of radio transmission	ISM 868 MHz, (the band 865 to 868 MHz)
Transmission power of the thermostat and radio module	20 mW (+13dBm)
Radio network topology	One radio module and up to 3 subordinate thermostats
Display	LCD with backlight
Controlling	Capacitive buttons
Dimensions	Thermostat: 87 mm x 97 mm x 27.3 mm Radio module: 70 mm x 50 mm 7.7 mm
Thermostat/radio module weight	0.2 kg/0.16 kg
The thermostat installation method	On the wall or free-standing
The radio module installation method	On the wall

# APPENDIX C - 3-PORT MIXER VALVE

## C.1 GENERAL

The Smart controller can manage the temperature of an adjustable circuit with the use of a motorised rotary actuator mounted on a 3 port valve.

When configuring the system using the creator, if you choose to use a mixing valve the creator will prompt for a valve opening time. This value is the time the actuator would take to move fully from one end of its movement spectrum to the other under nominal power and is used to calculate movement for mixing.

## C.2 CLOCKWISE ROTATION

### C.2.1 ASSEMBLY

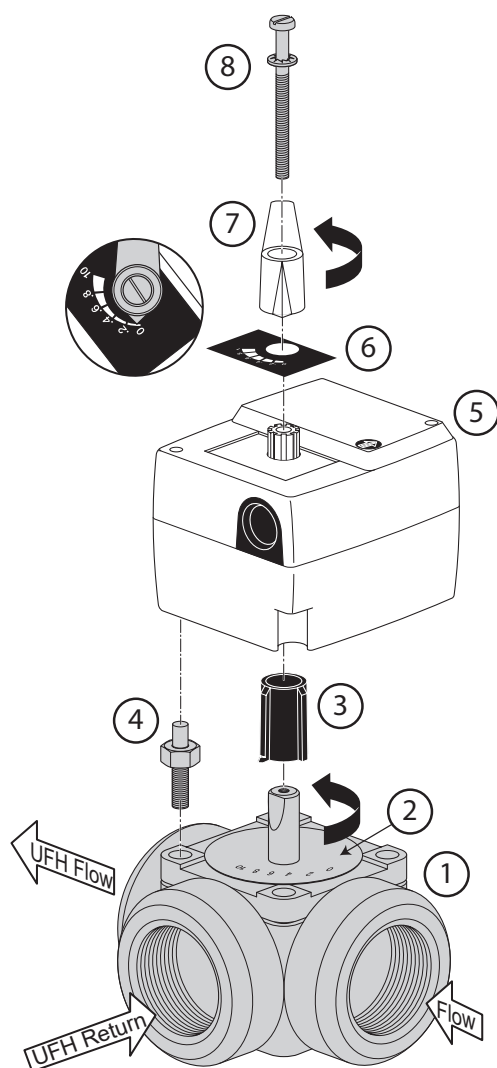

Figure C-1: Motorised Actuator and 3-Port Valve

Table C-1: Motorised Actuator and 3-Port Valve

Number	Description
1	3-Port valve
2	Body scale plate
3	Valve drive adaptor
4	Anti-rotation peg
5	Motorised actuator
6	Actuator scale plate
7	Rotary handle
8	Fixing Screw

To correctly assemble the 3-Port Mixing valve you will need to:

1. Ensure the clutch of the motorised actuator is disengaged allowing for free movement with the rotary handle. To disengage, place a screwdriver into the slot available, press down and turn clockwise. You will have disengaged when the arrow is facing the direction of the hand. Refer to Figure C-2.

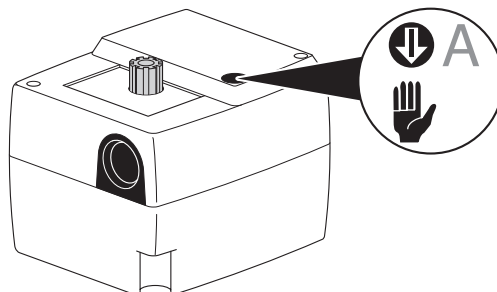

Figure C-2: Actuator gearing latch switch

2. Ensure actuator scale plate is in position and set as per Figure C-1. i.e. '0' to the left.
3. Fit the valve lever (supplied with the actuator) onto the splined shaft end. Rotate lever anticlockwise as far as possible. If necessary, remove and refit lever to point to '0' position on the scale.
4. Unscrew, remove and discard the fixing screw and blue handle attached to the supplied 3-port valve body
5. Fit the grey drive adaptor onto the 3-port valve spindle and turn until the pointer is facing the 0 position on the valve body scale plate. (The drive adaptor will only attach in one position).
6. Slot the Anti-rotation peg in place.

## ! NOTE !

If the Anti-rotation peg is not fitted the motorised actuator will spin in place and not turn the valve as required.

7. Place the motorised actuator onto the valve aligning the drive adaptor and ensure the Anti-rotation peg slots into the actuator body.
8. Insert the fixing screw through the rotary handle and fasten to a maximum torque pressure of 0.8Nm.
9. Reset the clutch of the actuator following step 1 to make the arrow point to A (Auto). If enabled the rotary handle will be locked in place.

## C.2.2 WIRING

The electrical cable supplied with the actuator is connected as follows:

Table C-2: Electrical cable wiring

Colour	Description
Brown	230V drive to close the valve
White	230V drive to open the valve
Blue	230V neutral

The motorised actuator is connected via the 2 lives and 1 neutral connection to the wiring centre of either H2-M (Circuit 2) or H3-M (Circuit 3). The live connections power the motor in either direction to open or close the valve as required. Refer to Section 5 Figure 5-1 for wiring centre schematic.

For example for circuit 2:

- H2-M On (Terminal 3) - White
- H2-M Off (Terminal 5) - Brown

**C.3 ANTI-CLOCKWISE ROTATION**  
**C.3.1 ASSEMBLY**

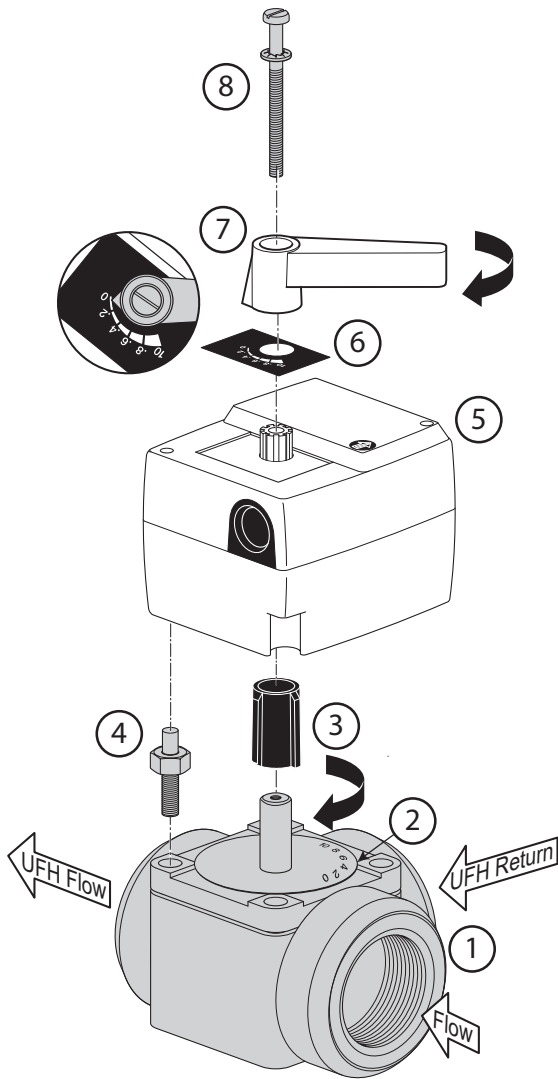

**Figure C-3:** Motorised Actuator and 3-Port Valve

To correctly assemble the 3-Port Mixing valve you will need to:

1. Ensure the clutch of the motorised actuator is disengaged allowing for free movement with the rotary handle. To disengage, place a screwdriver into the slot available, press down and turn clockwise. You will have disengaged when the arrow is facing the direction of the hand. Refer to Figure C-2.
2. Ensure actuator scale plate is in position and set as per Figure C-3. i.e. '0' to the right.
3. **Fit the valve lever (supplied with the actuator) onto the splined shaft end. Rotate lever clockwise as far as possible. If necessary, remove and refit lever to point to '0' position on the scale.**
4. Unscrew, remove and discard the fixing screw and blue handle attached to the supplied 3-port valve body.

**! NOTE !**

**The body scale plate is reversible and should be checked to ensure correct orientation.**

5. Remove the scale plate from the valve body. Carefully prise the circlip from the shaft. Lift the scale plate off, turn it over and refit with the '0' in the 3 O-Clock position. Refit circlip.
6. Fit the grey drive adaptor onto the 3-port valve spindle and turn until the pointer is facing the 0 position on the valve body scale plate. (The drive adaptor will only attach in one position).
7. Slot the Anti-rotation peg in place.

**! NOTE !**

**If the Anti-rotation peg is not fitted the motorised actuator will spin in place and not turn the valve as required.**

8. Place the motorised actuator onto the valve aligning the drive adaptor and ensure the Anti-rotation peg slots into the actuator body.
9. Insert the fixing screw through the rotary handle and fasten to a maximum torque pressure of 0.8Nm.

Reset the clutch of the actuator following step 1 to make the arrow point to A (Auto). When Auto is enabled the rotary handle will be locked in place.

**C.3.2 WIRING**

The electrical cable supplied with the actuator is connected as follows

**Table C-3:** Electrical cable wiring

Colour	Description
Brown	230V drive to open the valve
White	230V drive to close the valve
Blue	230V neutral

The motorised actuator is connected via the 2 lives and 1 neutral connection to the wiring centre of either H2-M (Circuit 2) or H3-M (Circuit 3). The live connections power the motor to move in either direction to open or close the valve as required. Refer to Section 4 Figure 4-1 for wiring centre schematic.

For example for circuit 3

- H3-M On (Terminal 6) - Brown
- H3-M Off (Terminal 8) - White

# APPENDIX D - HEATING ASSISTANCE

## D.1 GENERAL

The Anti-Legionella, Supplementary heating and Defrost Assistance functions provide control of externally connected immersion heater element via a relay.

Relays are factory-fitted and pre-wired within the wiring centre of the Grant QR2 Smart pre-plumbed cylinder for Anti-Legionella protection (Refer to Figure 4-2).

The Grant External volumiser (Aerona<sup>3</sup> only) and Grant Combined volumiser/Low-Loss header have a relay pre-installed and only need a 230V input to switch the relay. Refer to relevant installation documentation for further information.

The Grant Internal 50L volumiser will require a Grant Smart Immersion Relay (or other suitable relay) to be connected to the Aerona Smart Controller to enable the above functionality.

## D.2 WIRING

Supplementary heater relays are connected to H1 (Terminals 19 and 20) or H2 (Terminals 21 and 22). H1 (Back-up heater) is for use with an immersion heater installed in a volumiser or Low Loss header, while H2 (DHW) is dedicated for the cylinder immersion heater for Anti-Legionella protection. (Refer to Section 5 for electrical schematics).

A power source independent of the Grant QR2 Smart pre-plumbed cylinder must be provided for each externally connected immersion element.

## D.2.1 DHW CYLINDER IMMERSION HEATER

The Grant QR2 Smart pre-plumbed cylinder has the relay for Anti-Legionella protection factory-fitted and pre-wired (Refer to Figure D-1). Refer to Section 7.4 for instructions on how to enable and configure Anti-Legionella protection.

## D.2.2 SUPPLEMENTARY IMMERSION HEATER

Connecting the Smart controller to a Grant volumiser (Internal or External) or Low Loss header can provide supplementary heating to assist in meeting a space heating demand or provide defrost assistance during a heat pump defrost cycle. Refer to Figure D-1 for additional wiring requirements when connected in conjunction with the factory-fitted cylinder immersion.

## D.3 LEGIONELLA PROTECTION

Legionella protection can be scheduled on a weekly basis to heat the DHW cylinder to 60°C. Legionella disinfection should be scheduled in a window that is a minimum of 1 hour after a DHW demand and in a setback heating demand period e.g. Overnight. This is to minimise the heat loss in the heating circuits during DHW demands.

The Legionella protection provided by the Smart Controller can only be set to run once in a seven day period. Refer to Section 7.4 for Legionella protection.

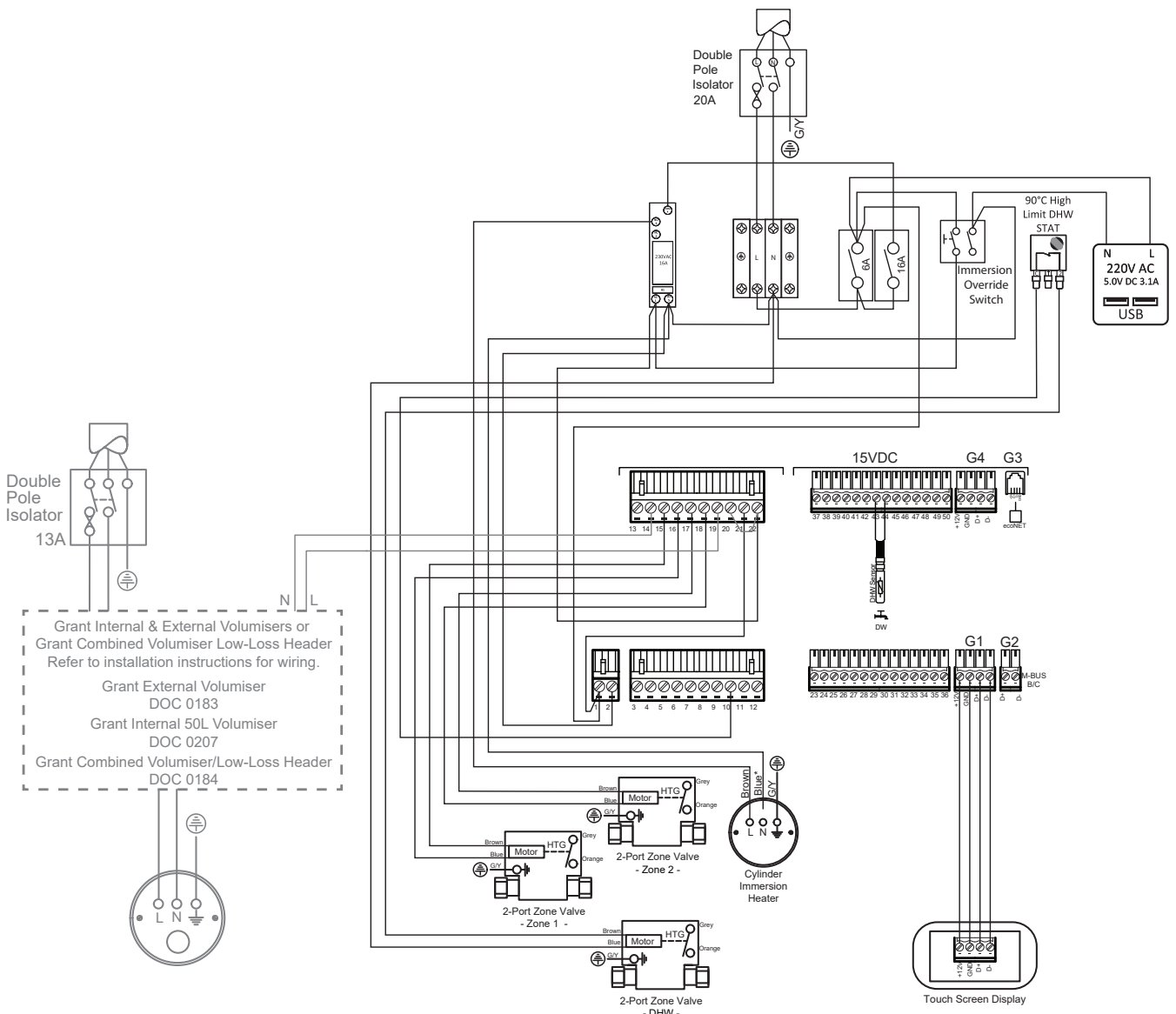

Figure D-1: Supplementary heating examples

#### **D.4 SUPPLEMENTARY HEATING**

The controller can be enabled to provide supplementary heating using an immersion heater in a Internal volumiser, External volumiser or Low Loss Header.

The Smart Controller enables the user to configure the time delay for the immersion heater to switch on after a specific demand has begun. Refer to Section 8 - Heaters for the settings of the time delay as well as temperature activation set points should they be required.

#### **D.5 DEFROST ASSISTANCE**

The Aeron Smart controller can aid Grant Aeron 290 and Grant Aeron<sup>3</sup> heat pumps when the heat pump enters a defrost cycle to provide additional heat into the water side of the plate heat exchanger in the heat pump from a volumiser installed on the return flow to the heat pump.

When entering a defrost cycle, the heat pump will:

- Reverse the refrigerant flow.
- Activate the circulating pump.
- Signal the Aeron Smart controller that a defrost cycle is active.

The Smart controller will then:

- Activate all configured heating circuits to 'ON' (If not already)
- (If configured) energise H1 (Back-up Heater) to provide assistance to the volumiser.
- (If configured) energise Terminal 46 (Electric Heater) on the Aeron<sup>3</sup> to provide assistance to the volumiser.

The heat from the volumiser as well as the space heating circuits will enter the plate heat exchanger and be transferred to the refrigerant, which is passed into the evaporator coil to thaw any formed ice.

Refer to Section 8 - Heaters for the settings for a Back-up Heater.

For further information on the Grant Internal 50L volumiser and Defrost assistance, Refer to DOC 0207 - Grant UK Internal 50L volumiser.

# APPENDIX E - SMART FLOW SENSOR

## E.1 GENERAL

The Grant Smart Flow sensor is designed to measure the flow rate within the installed system to determine the power output and the coefficient of performance (COP). Over time the function will also show the running SCOP.

## E.2 INSTALLATION

Grant UK recommend the Grant Smart Flow sensor should be installed internally on the return to the heat pump after the Grant MagOne magnetic filter.

If an external installation is required, the flow sensor should be protected to prevent exposure to the elements or other external interference.

In order to limit interference to the measurements given to the Grant QR2 Smart pre-plumbed cylinder controller, we recommend the minimum system pressure to be 1.4 bar to avoid damage from bubble formation and cavitation. You must take all due care to avoid water hammers during both installation and normal operation.

### ! CAUTION !

The sensor in the measuring tube of the Grant Flow sensor should not be exposed to mechanical loads.

For the optimum measurement accuracy, Smart Flow sensor should be installed as per A in Figure E-1. Vertically with increasing flow allows for the discharge of bubbles upwards and no danger of dirt or sediment deposits within a completely filled pipeline.

Interference from vortices created by bends can occur, so ensure correct distances from elbows are adhered to for calming sections when positioning the smart flow sensor. Refer to Table E-1.

Ensure isolation valves are set in a fully open position and not used control flow.

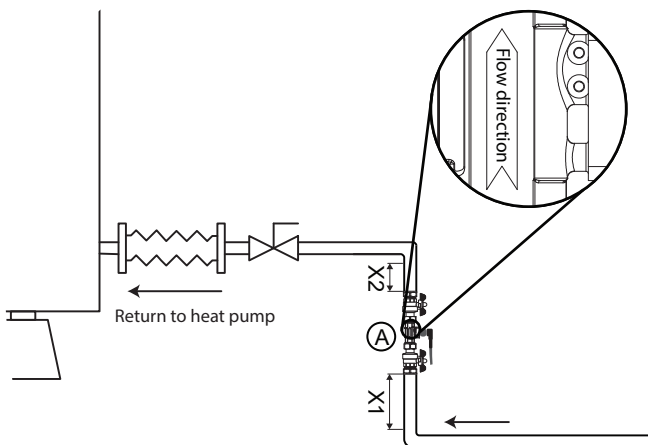

Figure E-1: Smart Flow sensor position A

### ! NOTE !

Changes in pipe diameter should be treated the same as bends and have suitable calming sections.

Position B (Refer to Figure E-2) would be suitable when installing horizontally. Ensure adequate calming sections before and after the flow sensor to avoid vortices and measurement disturbances. Refer to Table E-1.

Ensure isolation valves are set in a fully open position and not used control flow.

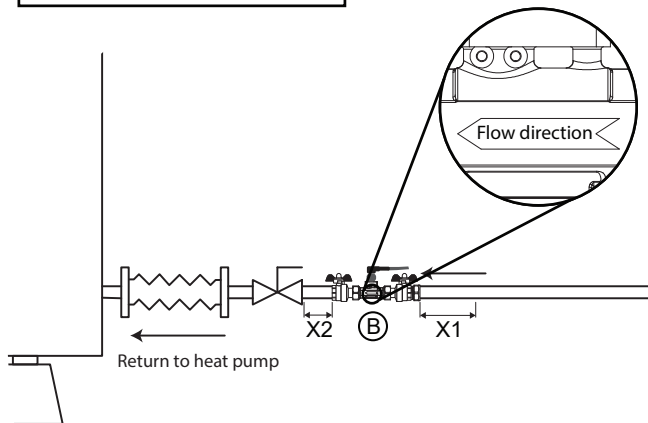

Figure E-2: Smart Flow sensor position B

Position C is unsuitable due to being prior to a point of decreasing flow, misreadings from bubbles formation and possible run empty.

Position D would be unsuitable again from being a point of decreasing flow, possible run empty and bubble discharge moving back through the flow sensor.

Refer to Figure E-3 for position C & D.

Ensure isolation valves are set in a fully open position and not used control flow.

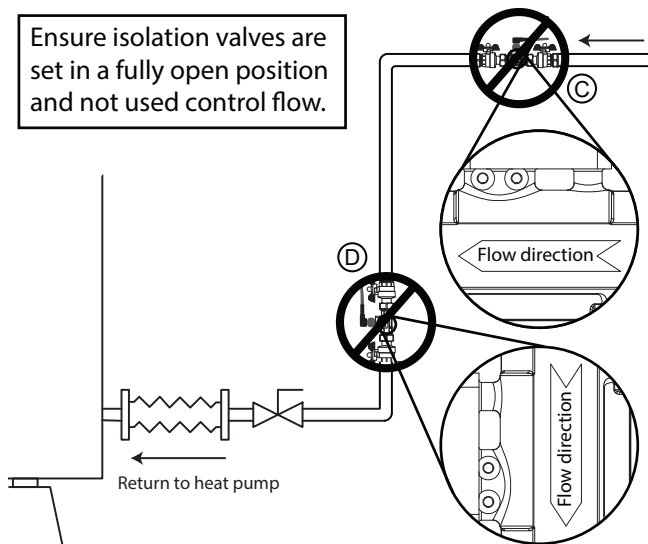

Figure E-3: Smart Flow sensor position C & D

Table E-1: Calming Section measurements

Inlet Section (X1)	Outlet Section (X2)
Minimum 10x DN	Minimum 5 DN

For example, for a pipe diameter of 28mm:

10 x 28mm = 280mm straight pipe before inlet to flow sensor before any bend or fitting

5 x 28mm = 140mm straight pipe after outlet of flow sensor before any bend or fitting.

When a suitable location has been determined:

1. Install suitable pipe fittings.
2. Ensure the flow sensor is correctly positioned as shown by the flow indicator on the outer body.
3. Insert the flow sensor with the O-rings as supplied.
4. Ensure the O-rings are correctly positioned on each end of the flow sensor before fitting the valve union nuts.

## **! CAUTION !**

**Avoid over tightening the union nuts and ensure to apply an equal counter force the union nut by using the hexagon of the Smart Flow sensor (Maximum torque of 15Nm). Ensure the electrical connection is pointing upwards or outwards.**

### **E.3 ELECTRICAL**

The Grant Smart Flow sensor is supplied with a pre-wired 5 core cable and connector.

- Align the connector with the flow sensor, taking note of the key.
- Insert and secure with the nut. Do not force or overtighten beyond hand tight.

Refer to Table E-2 and Section 5 pack schematics for wiring connections.

**Table E-2:** Smart Flow sensor wire connections

Wire Colour	Terminal Connection
Brown (Voltage)	+12V (G1 or G4)
White (Not connected)	-
Blue (Ground)	Terminal 32
Black (Signal)	Terminal 31
Grey (Not connected)	-

### **E.4 SENSOR CONFIGURATION**

Once installed, the Grant QR2 Smart pre-plumbed cylinder controller will need to be configured to use the Smart Flow sensor. You will need to access the flow sensor settings. This is found in service settings (Refer to Section 8).

**Table E-3:** Smart Flow Sensor configuration settings

Parameter	Value
Flow Meter	Pulse
Specific Heat Capacity	4.180
Time detect(seconds)	120
Time alarm erase(seconds)	30
No flow detection threshold (m <sup>3</sup> /h)	0.1
No flow detection hysteresis (m <sup>3</sup> /h)	0.1
Pulse rate	200
Pulse counting time(seconds)	1
Too often alarm	3

# APPENDIX F - COMMISSIONING CHECKLIST

After you have completed the initial setup and system configuration creator, follow and complete the points below. Some of the settings will already be set by the System Configuration creator. Ensure you have the devices required wired correctly.

Feature	Function Description	Manual Reference	Set Value
Installer only - Hydraulic settings for the Grant QR2 Smart pre-plumbed cylinder controller on installed systems.			
Circuit 1	<p><b>Radiator Circuit - S-Plan with Thermostat</b></p> <ul style="list-style-type: none"> <li>Configure Thermostat to circuit. (if not paired)</li> <li>Configure 'THERMOSTATIC PUMP BLOCKADE' for the required circuit(s).</li> </ul> <p><b>Radiator Circuit - Open Loop optimisation with Thermostat</b></p> <ul style="list-style-type: none"> <li>Configure Thermostat to circuit. (if not paired)</li> <li>Configure 'THERMOSTATIC PUMP BLOCKADE' for the required circuit(s).</li> </ul> <p><b>Radiator Circuit - Open Loop optimisation with No Thermostat</b></p> <ul style="list-style-type: none"> <li>No Thermostat configured</li> <li>Circuit Regulation (Weather/Fixed is measured on the return to the Heat pump). Circuit 1 will not close if target flow is exceeded by a higher demand from another circuit.</li> </ul>	<p>Section 7.3.1.4 Section 7.8</p> <p>Section 7.3.1.4 Section 7.8</p>	<p>ON</p> <p>OFF</p>
Circuit 2 & 3	<p><b>Radiators - S-Plan with Thermostat</b></p> <ul style="list-style-type: none"> <li>Check/configure 'PUMP ONLY' to disable mixing function.</li> <li>Configure Thermostat to circuit. (if not paired)</li> <li>Configure 'THERMOSTATIC PUMP BLOCKADE' for required circuit(s).</li> </ul> <p><b>Radiators - Open Loop optimisation with Thermostat</b></p> <ul style="list-style-type: none"> <li>Check/configure 'PUMP ONLY' to disable mixing function.</li> <li>Configure Thermostat to circuit. (if not paired)</li> <li>Configure 'THERMOSTATIC PUMP BLOCKADE' for required circuit(s).</li> </ul> <p><b>Radiators - S-Plan without Thermostat</b></p> <ul style="list-style-type: none"> <li>Check/configure 'PUMP ONLY' to disable mixing function.</li> <li>Configure 'CIRCUIT STOP FROM PRESET TEMP' for required circuit(s).</li> </ul> <p><b>Radiators - Open Loop optimisation without Thermostat</b></p> <ul style="list-style-type: none"> <li>Check/configure 'PUMP ONLY' to disable mixing function.</li> <li>Configure 'CIRCUIT STOP FROM PRESET TEMP' for required circuit(s).</li> </ul> <p><b>Underfloor Heating - S-Plan with no mixing valve &amp; No Thermostat</b></p> <ul style="list-style-type: none"> <li>Check/Configure 'PUMP ONLY' to disable mixing function.</li> <li>Configure 'CIRCUIT STOP FROM PRESET TEMP' for required circuit(s).</li> </ul> <p><i>Thermostatic mixing valve on Underfloor manifold to manage water temperature into the underfloor loops.</i></p> <p><b>Underfloor Heating - S-Plan with Thermostat &amp; No mixing valve</b></p> <ul style="list-style-type: none"> <li>Check/Configure 'PUMP ONLY' to disable mixing function.</li> <li>Configure 'CIRCUIT STOP FROM PRESET TEMP' for required circuit(s).</li> <li>Configure Thermostat to circuit. (if not paired)</li> <li>Configure 'THERMOSTATIC PUMP BLOCKADE' for required circuit(s).</li> </ul> <p><i>Thermostatic mixing valve on Underfloor manifold to manage water temperature into the underfloor loops.</i></p> <p><b>Underfloor Heating - S-plan with motorised mixing valve &amp; Thermostat</b></p> <ul style="list-style-type: none"> <li>Check/Configure 'PUMP ONLY' to enable mixing function.</li> <li>Configure Thermostat to circuit. (if not paired)</li> <li>Check/Configure valve opening time</li> <li>Configure 'THERMOSTATIC PUMP BLOCKADE' for circuit(s).</li> </ul> <p><b>External UFH Wiring Centre - Circuit 2 or 3 (Using 'T2' input)</b></p> <ul style="list-style-type: none"> <li>Check/Configure 'PUMP ONLY' to disable mixing function.</li> <li>Configure 'CIRCUIT STOP FROM PRESET TEMP' for Circuit 2 or 3.</li> <li>Configure Thermostat to circuit. (if not paired)</li> <li>Configure 'THERMOSTATIC PUMP BLOCKADE' for circuit.</li> <li>Check/configure Circuit 'Maximum Temp'. 45°C max. (To suit system design)</li> </ul> <p><b>'Thermostatic pump blockade'</b> - Circuit valve/pump will be deactivated based on the air temperature values from an installed thermostat meeting user set temperature.</p> <p><b>'Circuit stop at preset temp'</b> - Circuit valve/pump will be deactivated based on water flow temperature values. This is either user set 'Fixed set point water temperature' or weather compensated value.</p>	<p>Section 7.8 Section 7.3.1.4 Section 7.8</p> <p>Section 7.8 Section 7.3.1.4 Section 7.8</p> <p>Section 7.8 Section 7.8</p> <p>Section 7.8 Section 7.8</p> <p>Section 7.8 Section 7.8</p> <p>Section 7.8 Section 7.8 Section 7.3.1.4 Section 7.8</p> <p>Section 7.8 Section 7.3.1.4 Section 8 Section 7.8</p> <p>Section 7.8 Section 7.3.1.4 Section 7.3.1.4 Section 7.8 Section 8 - Circuit 2 &amp; 3</p>	<p>ON ON</p> <p>ON OFF</p> <p>ON ON</p> <p>ON OFF</p> <p>ON ON</p> <p>ON OFF ON</p> <p>OFF 140s ON</p> <p>ON OFF Contact ON</p>
Circuit Hysteresis Values	<p>Hysteresis values for installed Heat emitters.</p> <ul style="list-style-type: none"> <li>Radiators</li> <li>Underfloor Heating</li> </ul>	<p>Section 7.3.1.3 Section 7.3.1.3</p>	<p>4°C 1°C</p>

Feature	Function Description	Manual Reference	Set Value
<b>Installer only - Settings for Volumiser's</b>			
Supplementary heating - No defrost support	<p><b>Low Loss Header</b></p> <ul style="list-style-type: none"> <li>Check/Configure 'HYDRAULIC SCHEME'.</li> <li>Configure 'ADDITIONAL TEMP SENSOR'. <i>Water Temperature sensor will be required in BB - Refer to Section 4 and 5. If set to 'OFF' the temperature will be measured on the Heat pump return*.</i></li> <li>Configure 'PRESET WATER TEMP' for the Low Loss Header.</li> <li>Configure 'PRESET WATER HYSTERESIS' for Low Loss Header.</li> <li>Configure 'OFF CIRCUITS DURING CHARGING'.</li> </ul> <p><b>If Immersion supplementary heat is required for the Low Loss Header.</b></p> <ul style="list-style-type: none"> <li>Configure 'BACK-UP HEATER'.</li> <li>Configure 'BACK-UP HEATER DELAY'.</li> <li>Configure 'BACK-UP HEATER OPERATION IN DEFROST'.</li> <li>Configure 'OUTSIDE TEMP TO ACTIVATE THE HEATER'.</li> <li>Configure 'OUTSIDE TEMP FORCE THE HEATER'.</li> </ul> <p><i>* The controller will create a demand to the heat pump separate to any space heating demands until the return temperature is as per 'PRESET WATER TEMP' (used as the target flow temperature with no correction).</i></p>	<p>Section 8</p> <p>Section 8 Section 5</p> <p>Section 8 Section 8 Section 7.12</p> <p>Section 8 Section 8 Section 8 Section 8</p>	<p>Low Loss Header</p> <p>ON</p> <p>ON</p> <p>OFF</p>
Defrost Support - No Supplementary heating	<p><b>50 Litre Internal Volumiser</b></p> <ul style="list-style-type: none"> <li>Configure 'BACK-UP HEATER'.</li> <li>Configure 'BACK-UP HEATER OPERATION IN DEFROST'.</li> </ul> <p><i>* Defrost support will trigger H1 terminals when the heat pump enters Defrost in all hydraulic schemes. If Defrost support is enabled, you can not utilise supplementary heating for space heating demands.</i></p>	<p>Section 8 Section 8</p>	<p>ON ON</p>
<b>Installer only - Settings for all Grant QR2 Smart pre-plumbed cylinder controller installations.</b>			
Flow sensor	Configure the Grant flow sensor. (Aerona <sup>3</sup> R32 only)	Appendix E	
Aerona <sup>3</sup> Frost Protection	Check and adjust Frost protection parameters (Aerona <sup>3</sup> R32 only)	Appendix G	
Heat Pump Schedule	Configure Heat Pump work mode.	Section 7.6	ON
Smart Controller Work mode	Configure the Grant Aerona Smart controller for heating only.	Section 7.3.3	Work Mode: Winter
DHW Heater Support	<p>Configure DHW Heater for Legionella Protection</p> <ul style="list-style-type: none"> <li>DHW Heater</li> <li>DHW Heater (delay)*</li> </ul> <p><i>* This DHW Heater (delay) setting is based on a scheduled 1 hour DHW demand.</i></p>	<p>Section 7.4 Section 8</p>	<p>ON 75mins</p>
<b>Installer &amp; end-user - Settings for Grant QR2 Smart pre-plumbed cylinder controller installations.</b>			
Wi-Fi Hub	Connect the Wi-Fi Hub to end user internet connection. (Ethernet/Wi-Fi) End user to register UID with www.econet24.com. <i>(UID to be recorded for remote access &amp; Grant UK registration.)</i>	Section 10 Appendix H	
Heating circuit Day Mode temperature	Demonstrate and configure target air temperature for the heating circuit(s) for Day/Occupied times.	Section 7.3.1.2 Section 7.3.1.3	
Heating Circuit Night mode temperature ( <b>Setback</b> )	Demonstrate and configure target air temperature for the heating circuit(s) for Night/Unoccupied times. <i>Refer to Table 7-4 for suggested subtractive values based on circuit emitters.</i>	Section 7.3.1.2 Section 7.3.1.3	
DHW Cylinder temperature	Demonstrate and configure target DHW cylinder temperature.	Section 7.3.2.1	
DHW Secondary Circulation schedule	Demonstrate and configure DHW Secondary Circulation schedule (if installed)	Section 7.5.4	
Heating Circuit schedules	Demonstrate and configure Heating Circuit(s) schedule for Day/Night modes.	Section 7.5	Work mode: Auto
DHW Cylinder schedules	Demonstrate and configure DHW cylinder Schedules as well as 'BOOST'.	Section 7.3.2.2	Work Mode: Auto
Legionella protection	Check/Enable 'DHW HEATER' support. Enable and demonstrate & configure 'DISINFECTION'. (Day and Time specified by Cylinder schedule).	Section 7.4.1 Section 7.4.2	ON Temp: 60°C
Thermostats (If installed)	Demonstrate use to Thermostat panels to amend circuit target temperatures. Demonstrate how to assign/pair Thermostats to individual circuits. <i>End user will need to be informed if thermostats are being used as circuit controls and the issues related to removing them.</i>	Appendix A & B Section 7.3.1.1	
System Default	Save System default to Grant Smart Controller memory. Demonstrate how to recall a saved system default.	Section 7.10	

# APPENDIX G - AERONA<sup>3</sup> (R32)

## G.1 GENERAL

The Grant QR2 Smart pre-plumbed cylinder is compatible with both the Grant Aerona 290 and Grant Aerona<sup>3</sup> heat pump ranges.

Should it be required, it is also possible to retrofit the Grant Aerona Smart controller to an existing installed Grant Aerona<sup>3</sup> air source heat pump, following the guidance provided in Section G.3 and beyond.

## G.2 SERIAL NUMBER

Grant Aerona<sup>3</sup> R32 heat pumps manufactured on or after the date/serial number given in Table G-1 for that specific model can be retrofitted with the Grant QR2 Smart pre-plumbed cylinder, provided the previously supplied Aerona Remote controller remains connected to the heat pump.

The Aerona Remote controller can be removed only if the heat pump control PCB is replaced with the current version. The control PCB is not supplied as part of the Grant QR2 Smart pre-plumbed cylinder kit but is available to purchase from Grant Engineering UK Ltd. (Part Code: HPID885765)

All Grant Aerona<sup>3</sup> R32 and R410 heat pumps manufactured before the date/serial number given in Table G-1 for that specific model must have the heat pump control PCB replaced with the current version to enable it to be retrofitted with the Grant Aerona Smart controller. In this case, it is not necessary for the Grant Aerona remote controller to remain connected to the heat pump.

**Table G-1:** Pre February 2024 Serial numbers

Aerona <sup>3</sup> model	Date of manufacture	Serial number
HPID6R32	05/02/2021	6002007
HPID10R32	21/01/2021	6002249
HPID613R32	19/11/2020	6001193
HPID617R32	19/11/2020	6001401

This serial number for the heat pump can be found on the heat pump data label.

The data label is located on the outside of the heat pump casing:

- on the rear of the HPID6 models.
- on the right-hand end of the HPID10, HPID13 and HPID17 models.

## G.3 EXISTING CONTROLS

The existing controls will need to be disconnected from terminals 18, 19 and 20 on heat pump terminal PCB and removed as they will no longer be required. Existing space heating and hot water controls (room thermostats, cylinder thermostats, etc.) are also no longer required as these will be replaced during a Smart Controller installation. Refer to Section 3 for required components and Section 5 for Wiring.

All system & heat pump control functions including accessing and setting the heat pump operating parameters, fault codes and real time information, will be provided by the Grant Aerona Smart controller that will be connected to the heat pump via the Modbus connection (terminals 15 and 16) on the heat pump terminal PCB. Refer to Section 3 and 5 of the Smart Controller installation Instructions for further details.

If the previously installed Aerona Remote controller remains connected to the heat pump it effectively acts as an on/off switch for the heat pump and must be set to **ON** (Green LED is illuminated – Refer to figure G-1) for it to operate.

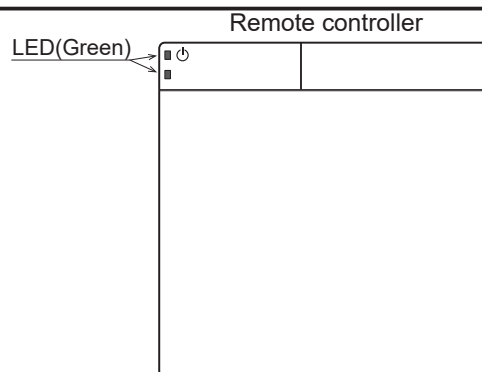

**Figure G-1:** Aerona Remote controller ON status

## G.4 UNDERFLOOR HEATING CONTROLS

If the heating system includes underfloor heating, the underfloor heating controls (room sensors, wiring centres, etc.) will need to be retained if it is intended that they will be used with the controller.

These can be connected to the Smart Controller wiring centre, as required. Refer to the Sections 4 and 5 for further details.

## G.5 CONNECTING THE MODBUS

The wiring centre must be connected to the Grant Aerona<sup>3</sup> R32 heat pump via the Modbus terminal socket (G2) of the wiring centre to Terminals 15(+) & 16(-) of the Grant Aerona<sup>3</sup> R32 heat pump. The shielding should be connected to the RS485 ground (Terminal 32) on the terminal PCB of the heat pump only. Refer to Figure G-2.

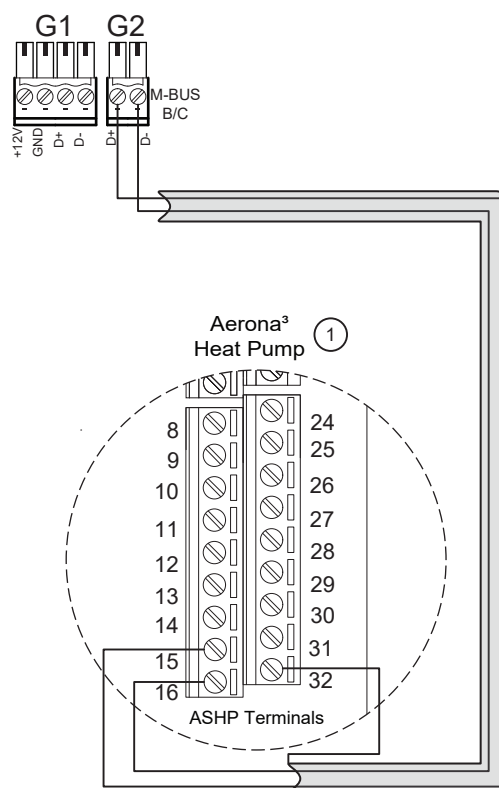

**Figure G-2:** Modbus Connection

**! NOTE !**

Shielded, twisted pair cable **MUST** be used for the modbus connection between the wiring centre and Grant Aerona<sup>3</sup>. Shielded Cat 5/6 is suitable for use.

## G.6 AERONA<sup>3</sup> FROST PROTECTION

After the system has been configured, check and if needed activate the frost protection within the Heat pump parameters menu via the touchscreen display (Refer to Table G-2).

**To access the Heat pump parameters menu:**

1. Tap the Settings menu and select 'Service settings' and enter the password: **1234**. Refer to Table 7-1 and Section G.9 for full Aeronas<sup>3</sup> R32 Heat pump parameters listing.

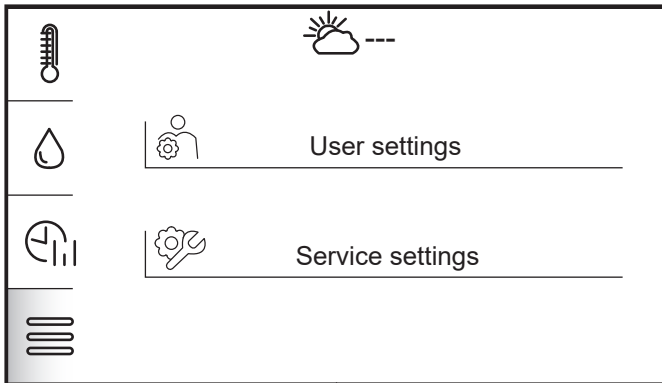

**Figure G-3:** Settings menu

**Table G-2:** Frost protection parameters

Parameter No.	Parameter Title	Setting Value
Frost protection		
43 00	Frost Room Temp	ON
43 10	Frost Ambient Temp	ON
43 20	Frost Flow Temp	ON

By default, these should be set as ON on the heat pump. For further information on the frost protect functionality of the Aeronas<sup>3</sup> heat pump range, refer to your supplied user manual for the Grant Aeronas<sup>3</sup> heat pump (DOC 0136).

## G.7 SERVICE ALARM

In the event of an active 'Service Alarm' being displayed via the Smart controller, refer to Section 11 of the supplied user manual for the Grant Aeronas<sup>3</sup> heat pump (DOC 0136) for details on how to view the specific error codes via the terminal PCB display and associated other fault finding information.

## G.8 IMMERSION RELAY

Grant Aeronas<sup>3</sup> R32 heat pumps can raise the DHW cylinder to around 50 to 55°C during standard operation.

Using the factory-fitted Immersion relay, the Grant Aeronas<sup>3</sup> Smart Controller can enable an installed immersion element to work in tandem with the heat pump to raise the water temperature in a DHW cylinder to a preset temperature.

The Legionella protection function will set a temporary DHW cylinder temperature and then activate the heat pump and immersion element to raise to the water temperature. When the cylinder has reached this temperature, it will stop.

By default, the temperature is 70°C which is sufficient to kill any legionella present.

For more information on the setup of Legionella protection, refer to Section 7.4.

**\*For Section G9 continue to page 82.**

## G.9 AERONA<sup>3</sup> R32 HEAT PUMP PARAMETERS

With the R32 firmware installed to access the heat pump parameters menu, Tap the Settings menu (Refer to Figure 7-1) and tap 'SERVICE SETTINGS'. Input the relevant password **1234** on the keypad and tap enter.

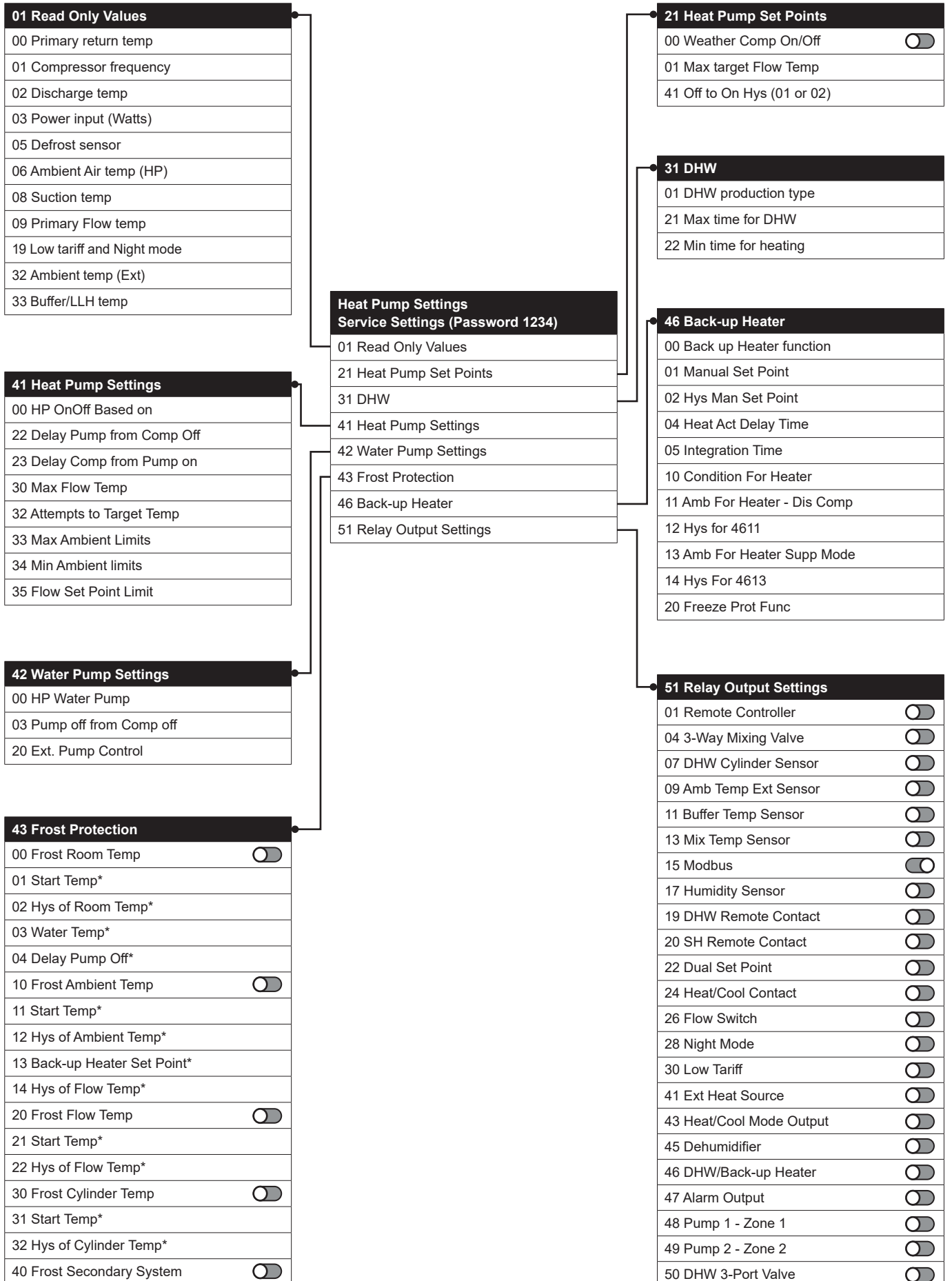

Parameter	Description
01 Read only Values	Heat Pump operating conditions - Displayed information directly from the Heat pump.
21 Heat Pump Set Points	21 00 - Enable/Disable Weather Compensation on Heat Pump (Do not enable) 21 01 - Setting for the Maximum Target Flow temperature (Smart controller adjusts automatically) 21 41 - Hysteresis set point to enable the Heat pump
31 DHW	31 01 - Heat pump priority on DHW demand 31 21 - Max time the Heat pump can run for a DHW demand 31 22 - Minimum time for a Space heating demand
41 Heat Pump Settings	41 00 - Heat Pump control based on selected set point 41 22 - Delay time for Pump off after compressor off 41 23 - Delay time for Compressor on after Pump on 41 30 - Maximum Flow temperature set point for Heating and DHW 41 32 - Set the max number of attempts for Heat pump to reach target temperature 41 33 - Maximum ambient temperature at which the Heat pump will operate 41 34 - Minimum Ambient temperature at which the Heat pump will operate 41 35 - Flow set point limits
42 Water Pump Settings	42 00 - Operation settings of Water pump 42 03 - Delay time of Water pump OFF from Compressor OFF 42 20 - Operation settings for an external secondary Water pump
43 Frost Protection	43 00 - Frost Detection based on room temperature 43 01 - Start Temperature set point for frost protection based on room temperature 43 02 - Hysteresis of room temperature to activate frost protection based on room temperature 43 03 - Temperature set point of circulated water 43 04 - Time delay for water pump to be deactivated on frost protection end 43 10 - Frost detection based on ambient temperature 43 11 - Start temperature for Frost protection on Ambient Temperature 43 12 - Hysteresis of Ambient temperature 43 13 - Temperature Set point for Back-Up Heater 43 14 - Flow Temperature Hysteresis 43 20 - Enable/Disable Frost protection on Outgoing flow temperature 43 21 - Start Temperature for 43 20 43 22 - Hysteresis of 43 20 43 30 - Enable/Disable Frost protection on DHW Cylinder temperature 43 31 - Start temperature for 43 30 43 32 - Hysteresis for 43 30 43 40 - Frost Secondary System - Frost Protection for a slave heat pump connected in cascade.
46 Backup Heater	46 00 - Enable/Disable Back-up Heater 46 01 - Back-up Heater Temperature Set point 46 02 - Hysteresis for 46 01 46 04 - Delay time for Back-up Heater activation 46 05 - Integration time for starting the heater 46 10 - Power condition of Back-up Heater 46 11 - Ambient temperature for enabling Heater & Disable compressor 46 12 - Hysteresis for 46 11 46 13 - Ambient temperature to activate Heater Supplementary mode 46 14 - Hysteresis for 46-13 46 20 - Enable/Disable Freeze Protection Function
51 Relay Output settings	Enable/Disable Heat Pump terminal PCB relays as listed - Refer to Figure 9-1

## ! NOTE !

**\* Dynamic menu items within the menu will change depending on configured system.**

# APPENDIX H - ECONET

## H.1 ECONET24

The ecoNET24 platform provides remote access to the Aerona Smart controller for monitoring and management.

There are two levels of account access:

- **Homeowner** – ability to monitor and control a single installation. A customer’s personal data is only visible at this level.
- **Installer** (Service engineer) – ability to monitor and control multiple installations. Each controller UID must be added independently to be visible on this account. Remote monitoring and access is possible if homeowner has set their system to ‘PREVIEW’ or ‘MODIFICATION’ mode. Remote monitoring and access will not be possible if homeowner has ‘FORBIDDEN’ access.

### H.1.1 HOMEOWNER ACCOUNT REGISTRATION

The Homeowner account is designed to only monitor a single Aerona Heat Pump installation with a smart controller.

- This account should be set up under the homeowner’s email address and can be accessed from either the ecoNET app or web-based portal.
- The homeowner will need to agree to the Terms of Use.

## ! NOTE !

To use the app you will need to first register via the website at [www.econet24.com](http://www.econet24.com).

If you are creating a homeowner account for the first time:

- you will need to enter the UID as part of the registration process.
- The ecoNET web-portal will verify the UID is both correct and available to be assigned to an account before the homeowner can enter any further details. Refer to Section H.1.2 on how to obtain the UID from your Grant Aerona Smart controller.

A homeowner with an existing ecoNET account can assign their controller UID to their ecoNET account within the web based ecoNET portal.

- Navigating to the top right corner, selecting the person icon and then ‘MY ACCOUNT’ from the drop down menu.
- In the left hand menu, select ‘MANAGE DEVICES’.
- Enter the UID into the ‘ADD CONTROLLER’ field and click Submit.

When the account is registered, the Wi-Fi hub will display it is connected with the external server (‘Server connection’ LED indicator will be active).

### H.1.2 HOW TO OBTAIN THE UID

Follow the steps to obtain the UID.

1. When the heating circuit control interface is shown (see Figure 7-1), tap settings menu. Refer to Table 7-1 and Figure H-1.

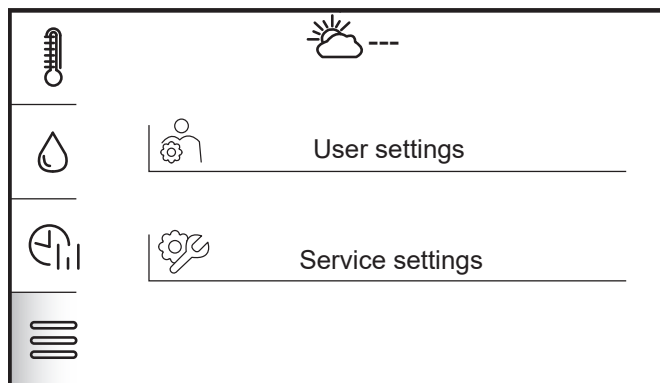

Figure H-1: Settings selection

2. Then tap the User settings. Refer to Figure H-2.

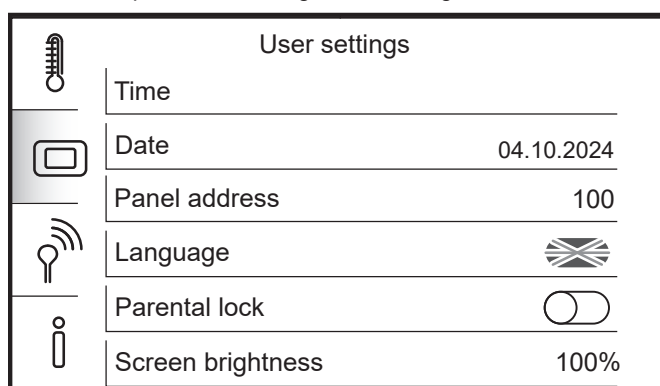

Figure H-2: User settings menu

3. Tap the information icon at the bottom. Refer to Figure H-3.

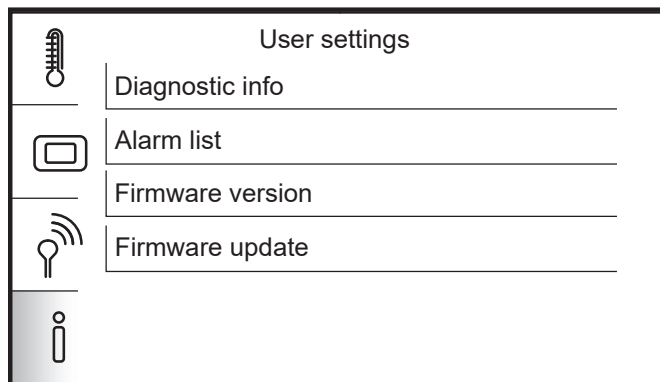

Figure H-3: Controller information options.

4. Then tap 'FIRMWARE VERSION'. Refer to Figure H-4.

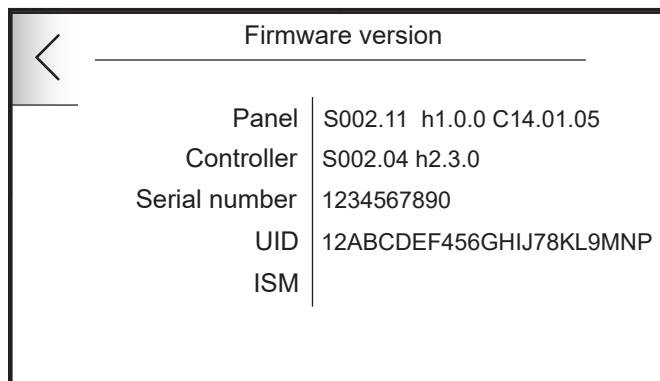

Figure H-4: Firmware version and UID

### H.1.3 REMOTE ACCESS MANAGEMENT

Within the ecoNET account via the web-portal, the homeowner can also control remote external access rights to their smart controller installation. This setting applies to all available external access accounts.

- Navigate to 'DEVICE SETTINGS' on the web-portal home screen.
- Locate 'OTHER SETTINGS' at the bottom of the list on screen.
- The label given to the installation will be displayed along with a drop down that will present the 3 options available.
  - **Preview** – Read only access
  - **Modification** – Edit access
  - **Forbidden** – No access

### H.1.3 TRANSFER OF OWNERSHIP

If the smart controller is assigned to an account, that account will need to be removed from ecoNET24 to release the UID.

An existing homeowner can remove their account via the web based ecoNET portal.

- Navigating to the top right corner, selecting the 'PERSON ICON' and then 'MY ACCOUNT' from the drop down menu.
- In the left-hand menu, select 'REMOVE ACCOUNT'.
- The remove account page will prompt for the user to enter the current password for the account to.
- After entering the current password click the 'DELETE' button to confirm.

An incoming homeowner without an ecoNET account will need an unassigned UID to start the registration of their ecoNET24 account. (Refer to Section H.1.1).

## ! NOTE !

**A device UID can only be registered to a single ecoNET24 homeowner account.**

### H.1.4 G1 REMOTE ACCESS ACCOUNT

**This account level is available to G1 heat pump installers only** and can only be accessed via the ecoNET web-based portal.

G1 heat pump installers can apply for this account level through their G1 Portal.

- In the left-hand navigation menu, click on 'ECONET24 APPLICATION' and complete the form.
- Following submission, this form will be sent to the software provider and a copy to the Pre-Sales Technical Team.
- The Grant Pre-Sales technical team will issue login details including a temporary password to the G1 heat pump installer via email within 48 hours.
- The installer should consider changing their password on their first log in.

We recommend this account be setup in advance of their first (or next) Aeron smart controller installation. This will allow the G1 installer to both check the functionality and demonstrate it for the homeowner.

For the installer to add a controller to their account, the homeowner account must first be registered.

- Navigate to the top right corner, selecting the person icon and then 'MY ACCOUNT' from the drop down menu.
- In the left hand menu, select 'MANAGE DEVICES'.
- Enter the UID into the 'ADD CONTROLLER' field and click Submit.

To allow permission for remote access the homeowner must toggle the remote access rights to be either 'PREVIEW' (read only) or 'MODIFICATION'. Refer to Section H.1.3.

For more information about the G1 Installer Scheme, please visit:

**Table H-1: QR Code - G1 Scheme Overview**

QR Code	Link
	<a href="http://www.grantuk.com/professional/g1-scheme/">GrantUK G1 Scheme Overview www.grantuk.com/professional/g1-scheme/</a>

# APPENDIX J - EVOLINK SMART

## J.1 EVOLINK SMART

The EvoLink Smart is an accessory to the Grant Aerona Smart Controller to utilise both a Grant Aerona Air Source heat pump as the main heat source (MHS) and a additional heat source (AHS) e.g. a boiler to provide heated system water in the most economical way possible.

Refer to UK DOC 0209 - Grant EvoLink Smart Installation and Operating instructions for further information.

## J.2 PARAMETERS

To configure the EvoLink Smart you will first need to activate the 'Additional Heat Source' functions of the Aerona Smart controller either by:

- Enabling during the configuration wizard. (Refer to Section 6)
- Enabling from the System settings menu. (Refer to Section 8)

**Table J-1:** AHS (Boiler) settings menu - Smart Controller

Parameter	Description	Parameter values			
		Default	Min	Max	Unit
AHS Enable	Toggle icon to activate or deactivate AHS (Boiler) support. <b>This will be ON if it was configured during System configuration creator.</b>				
AHS Pump settings	Sub menu for PWM pump control. (Refer to Table 5-2)				
Work in alarms	Allow EvoLink Smart to operate when MHS (Heat Pump) in Alarm state.	N			
MHS below setpoint delta - CH	Temperature below setpoint the MHS (Heat Pump) needs to achieve in setpoint time to activate AHS (Boiler) for space heating demands	3	0	15	°C
MHS below setpoint time - CH	Time value in which MHS (Heat Pump) should reach setpoint delta value for space heating demands upon start to activate AHS (Boiler)	45	0	180	mins
MHS below setpoint time again - CH	Time value counter from first setpoint in which the MHS (Heat Pump) should reach setpoint delta to activate AHS (Boiler)	15	0	180	mins
MHS below setpoint delta - HDW	Temperature below setpoint the MHS (Heat Pump) needs to achieve in setpoint time to activate AHS (Boiler) for DHW demands	3	0	15	°C
MHS below setpoint time - HDW	Time value in which the MHS (Heat Pump) should reach setpoint delta value for DHW demands to activate AHS (Boiler)	10	0	180	mins
MHS stop temp	Toggle icon to enable MHS (Heat Pump) to stop supplying heat at configured temperatures				
MHS stop temp	Temperature value at which the MHS (Heat Pump) stops supplying heat for demands	-5	-30	-4	°C
MHS start temp	Temperature value at which the MHS (Heat Pump) starts supplying heat for demands	-4	-5	5	°C
Stop AHS - pump power threshold	PWM pump speed to start under threshold counter to turn off AHS (Boiler) during a demand for space heating	32	0	100	%
Stop AHS - time under threshold	Time counter for pump power threshold to be under value to turn off AHS (Boiler) during a demand for space heating	20	0	180	mins
Stop MHS - return reached delta	Temperature value of delta between flow and return of the MHS (Heat Pump) to stop MHS (Heat Pump) compressor	2	0	15	°C
MHS pump power when AHS only	MHS PWM pump speed when AHS only	100	0	100	%

**Table J-2:** AHS (Boiler) Pump settings sub menu - Smart Controller

Parameter	Description	Parameter values			
		Default	Min	Max	Unit
Pump characteristic	Configure pump type for operation H: Heating S: Solar	H			
Startup percentage	PWM startup power.	17	0	100	%
Minimum power	Minimum power setting of PWM pump	17	0	50	%
Maximum power	Maximum power setting of PWM pump	100	0	100	%
Max power step change	PWM power adjustment for temperature adjustments	10	0	50	%
Adjustment time	Time for PWM power step to be adjusted	15	5	300	secs
PID: Kp	PID Controller settings	2			
PID: Ti		160			
PID: Td		30			
AHS-MHS temp difference to start	Temperature delta between AHS (Boiler) flow and MHS (Heat Pump) flow for PWM pump to start mixing.	5	-50	20	°C
AHS-MHS temp difference to stop	Temperature delta between AHS (Boiler) flow and MHS (Heat Pump) flow for PWM pump to stop mixing.	0	-50	20	°C

Table J-1 indicates the main Additional heat source menu options for the operation of the EvoLink Smart in relation to both ambient and MHS temperature conditions for both space heating and hot water demands.

Table J-2 is the sub-menu options specific to the control of the pump fitted in the EvoLink Smart as part of the overall operation of the device.

### J.3 OPERATION

The EvoLink Smart is managed by the Aerona Smart Controller to utilise a Grant Aerona heat pump as the main heat source (**MHS**), and an additional heat source (**AHS**) e.g. a boiler, to provide heated system water in the most economical way possible.

Refer to UK DOC0209 Section 5 for further information on commissioning and parameters for the operation of the EvoLink Smart.

## ! NOTE !

**Boiler flow temperatures will not be managed from the Smart Controller and will need to be set manually.**

**The Smart Controller will also not manage the modulation of the boiler.**

#### J.3.1 SPACE HEATING

- If there is a space heating demand, the Aerona Smart Controller will operate the MHS as designed for the circuit or circuits configured on the smart controller.
- The output flow temperature measured from the system flow pipe is determined by the highest required flow temperature from the configured system. This will include weather compensated or set point temperature and any configured temperature corrections.
- If the MHS is not able to reach the desired flow temperature '**MHS below setpoint delta - CH**' within a period of time '**MHS below setpoint time - CH**' or consecutive '**MHS below setpoint time again - CH**', the Aerona Smart Controller will activate the AHS (boiler) and the boiler flow is circulated through the left hand section of the EvoLink header.
- When the boiler flow temperature on the boiler flow pipe is above the Evolink flow sensor temperature by the configured amount '**AHS-MHS temp difference to start**', the PWM mixing pump will start, pulling the boiler flow into the right hand section of the header and mixing it with the heat pump flow to achieve the required weather compensated flow temperature.
- As the ambient outside temperature falls, and the heat demand on the system increases, the required higher weather compensated flow temperature in the mixing tank is achieved by using a greater amount of the boiler flow until the weather compensated flow temperature is achieved.
- This may be at the maximum flow temperature from the boiler.
- Once started, even when the required weather compensated flow temperature has been achieved, the boiler will remain in operation until either,
  - a) the end of that heating demand, i.e., until the room thermostat or programmer switches off.
  - or
  - b) when the heating load diminishes and deltaT across the system '**Stop MHS - return reached delta**', where it will be automatically switched off.

#### J.3.2 HOT WATER

- If there is a hot water demand from the Smart Controller, any space heating demands will be cut, causing any valves or pumps associated to space heating to close/stop and valves/pumps associated with DHW supply to open/start.
- The heat pump operates to achieve the calculated flow temperature to the DHW cylinder. This will be calculated based on configured cylinder set point and any additional temperature corrections.
- If the MHS is not able to reach the desired flow temperature '**MHS below setpoint delta - HDW**' within a period of time '**MHS below setpoint time - HDW**' or consecutive '**MHS below setpoint time again - HDW**', the Aerona Smart Controller will activate the AHS (boiler) and the boiler flow is circulated through the left hand section of the EvoLink header.
- When the boiler flow temperature on the boiler flow pipe is above the Evolink flow sensor temperature by the configured amount '**AHS-MHS temp difference to start**', the PWM mixing pump will start, pulling the boiler flow into the right hand section of the header and mixing it with the heat pump flow to achieve the required weather compensated flow temperature.

- As the ambient outside temperature falls, and the heat demand on the system increases, the required higher flow temperature in the mixing tank is achieved by using a greater amount of the boiler flow until the temperature is achieved.
- This may be at the maximum flow temperature from the boiler.
- Once started, even when the required flow temperature has been achieved, the boiler will remain in operation until either,
  - a) the end of that DHW demand, i.e., controller ends demand.
  - or
  - b) when the heating load diminishes and deltaT across the system '**Stop MHS - return reached delta**', where it will be automatically switched off.

#### J.3.3 BOILER ONLY (SPACE HEATING & DHW)

- When there is a Space heating or DHW demand and the outside air temperature is below or falls to below the '**MHS stop temp**' setting, the boiler will be automatically started and become the 'lead' heat source. The MHS circulating pump will be activated by the Aerona Smart Controller but the compressor and fans will not operate as it will be inefficient for it to do so at this low outside air temperature.
- If the outside temperature rises to above the '**MHS start temp**' setting, the boiler, and the EvoLink circulating pump, will be automatically switched off and the heat pump will start up as lead heat source.
- Should the occupier feel the system is not performing sufficiently for their own comfort, the '**MHS stop temp**' can be adjusted to initiate the boiler only function at a higher ambient temperature (default: -5°C). The '**MHS start temp**' will need to be adjusted accordingly to ensure no conflict in parameters.

### J.4 ADJUSTING THE EVOLINK SMART

The default settings for the EvoLink Smart (Refer to Table J-1 & J-2) have been created as a base to operate the heat pump (**MHS**) and boiler (**AHS**) in an efficient manner.

Prior to adjusting any of the settings, it is advised to contact Grant UK for further guidance as any adjustments made from these default settings may lead to increased costs from energy used.

- **MHS Stop temp:** Adjust the temperature where the AHS becomes the only heat source. Ensure the '**MHS Start temp**' is also adjusted accordingly to avoid conflicts.
- **MHS below setpoint delta - CH/HDW:** Adjust the temperature delta value that the heat pump needs to meet the target flow demand. An increase will enable the boiler sooner.
- **MHS below setpoint time - CH/HDW:** Adjust the time in which the heat pump needs to meet the target flow demand before the boiler is activated. A decrease will enable the boiler sooner.

#### J.5 HEAT PUMP (MHS) OVERRIDE

The Grant EvoLink Smart Control system has the ability to operate the boiler only, without the heat pump to:

- allow the boiler to be serviced or repaired.
- allow the operation of the boiler only to be used at times deemed uneconomical for the heat pump.

The boiler will respond to system demands from the Smart Controller as the only available heat source. For example, when servicing the boiler, the thermostats can be increased to create the demand and in turn activate the boiler.

Refer to Section 7.6 of this manual and UK DOC 0209 - Grant EvoLink Smart Installation and Operating instructions for further details.

# ONLINE RESOURCES

## AERONA SMART CONTROLLER - HOW TO PLAYLIST

QR CODE	Description
	<p><b>How to video guides playlist for the Grant Aeron Smart Controller.</b></p> <p>The playlist offers a number of helpful guides on how to set individual elements of the Grant Aeron Smart controller and is monitored and updated to ensure the best possible assistance is available.</p> <p>Can't find something specific? Email <a href="mailto:info@grantuk.com">info@grantuk.com</a> or contact your local sales representative for further assistance.</p>

## SCHEMATICS

QR CODE	Description
	<p><b>Grant UK online portal for approved schematic drawings.</b></p> <p>The schematics provided give a generalised idea on how to hydraulically and electrically design an installation using the Grant Aeron Smart controller.</p> <p>For further information or queries please contact <a href="mailto:into@grantuk.com">into@grantuk.com</a> or your local sales representative.</p>

## HEAT PUMP ORDERING PROCESS

QR CODE	Description
	<p><b>Grant UK Heat Pump ordering process</b></p> <p>The Grant UK heat pump ordering process for heat pumps (Aeron3 and Aeron 290 models).</p> <p>For further information or queries please contact <a href="mailto:into@grantuk.com">into@grantuk.com</a> or your local sales representative.</p>

# INSTALLATION, COMMISSIONING & SERVICE RECORD LOG BOOK

## Customer Details

Customer Name	
Customer Address	
TEL No.	

## ! NOTE !

1. This Log Book is only for use in Great Britain.
2. Please, keep the Log Book in a safe place for future reference.
3. This Log Book is to be completed in full by the competent person(s) who commissioned the equipment and then handed to the customer. When this is done, the Log Book is a commissioning certificate that can be accepted as evidence of compliance with the appropriate Building Regulations.
4. Failure to install and commission this appliance to the manufacturer's instructions may invalidate the guarantee (refer to Section 13 - Guarantee).

## Installer & Commissioning Engineer Details

Company Name		Date	
Company Address			
Installer Name		TEL No.	
Registration Details			
Registered operative ID card NO. (if applicable)			

## Commissioning Engineer Details (if different)

Company Name		Date	
Company Address			
Installer Name		TEL No.	
Registration Details			
Registered operative ID card NO. (if applicable)			

# ! NOTE !

**IT IS THE RESPONSIBILITY OF THE INSTALLER TO COMPLETE THIS LOGBOOK AND PASS IT ON TO THE CUSTOMER, FAILURE TO DO SO MAY INVALIDATE THE CYLINDER GUARANTEE.**

## Appliance and Time Control Details

Manufacturer	<b>GRANT UK</b>	Model	
Capacity	Litres	Serial No.	
Type	<b>Unvented</b>		
Time Control	Programmer <input type="checkbox"/> or Time Switch <input type="checkbox"/>		

## COMMISSIONING PROCEDURE INFORMATION

### Heat Source Primary Settings (indirect heating only)

Is the primary a sealed or open vented system? Sealed  Open

What is the primary heat source flow temperature? \_\_\_\_\_ °C

### Incoming Water Supply Information

What is the incoming static cold water pressure at the inlet to the pressure reducing valve? \_\_\_\_\_ Bar

Has strainer (if fitted) been cleaned of installation debris? YES  NO

Has a water scale reducer been fitted? YES  NO

What type of scale reducer has been fitted?

### Hot Water Cylinder Information

Are combined temperature and pressure relief valve and expansion valve fitted and discharge tested? YES  NO

Is primary energy source cut out fitted (normally 2-Port valve)? YES  NO

What is the pressure reducing valve setting (if fitted)? \_\_\_\_\_ Bar

Where is operating pressure reducing valve situated?

Has the expansion vessel or internal air space been checked? YES  NO

What is the hot water temperature at the nearest outlet? \_\_\_\_\_ °C

## Hot Water System Information

Does the hot water system comply with the appropriate Building Regulations? YES

---

Has the system been installed and commissioned in accordance with the manufacturer's instructions? YES

---

Have you demonstrated the operation of the system controls to the customer? YES

---

Have you left all the Manufacturer's literature with the customer? YES

---

Competent Person's Signature		Customer's Signature (To confirm demonstrations of equipment and receipt of appliance instructions)	
------------------------------	--	--	--

## SERVICE INTERVAL RECORD

It is recommended that your hot water system is serviced regularly and that your service engineer completed the appropriate Service Interval Record below.

# ! NOTE !

### SERVICE PROVIDER

Before completing the appropriate Service Record below, please ensure you have carried out the service as described in the manufacturer's instructions and in compliance with all relevant codes of practice.

<b>Service 1</b>	Date:
	Engineer name:
	Company name:
	TEL No.
	Comments
	Signature

<b>Service 6</b>	Date:
	Engineer name:
	Company name:
	TEL No.
	Comments
	Signature

<b>Service 2</b>	Date:
	Engineer name:
	Company name:
	TEL No.
	Comments
	Signature

<b>Service 7</b>	Date:
	Engineer name:
	Company name:
	TEL No.
	Comments
	Signature

<b>Service 3</b>	Date:
	Engineer name:
	Company name:
	TEL No.
	Comments
	Signature

<b>Service 8</b>	Date:
	Engineer name:
	Company name:
	TEL No.
	Comments
	Signature

<b>Service 4</b>	Date:
	Engineer name:
	Company name:
	TEL No.
	Comments
	Signature

<b>Service 9</b>	Date:
	Engineer name:
	Company name:
	TEL No.
	Comments
	Signature

<b>Service 5</b>	Date:
	Engineer name:
	Company name:
	TEL No.
	Comments
	Signature

<b>Service 10</b>	Date:
	Engineer name:
	Company name:
	TEL No.
	Comments
	Signature

# NOTES

# NOTES

# NOTES



**GRANT ENGINEERING (UK) LIMITED**

Frankland Road, Blagrove Industrial Estate, Swindon, SN5 8YG  
Tel: +44 (0)1380 736920 Fax: +44 (0)1380 736991  
Email: [info@grantuk.com](mailto:info@grantuk.com) [www.grantuk.com](http://www.grantuk.com)