

Grant Aerona

Smart Heat Pump System Controller

Installation & Operating Instructions



For use with
Grant
Aerona 290
& Grant
Aerona³
Heat pumps

IMPORTANT NOTE FOR INSTALLERS

These instructions are intended to guide installers on the installation and commissioning of the Grant Aerona Smart Controller intended for use with Grant Aerona air source heat pumps. After installing the unit, leave these instructions with the user.

SPECIAL TEXT FORMATS

The following special text formats are used in these instructions for the purposes listed below:

! WARNING !

Warning of possible human injury as a consequence of not following this instruction.

! CAUTION !

Caution concerning likely damage to equipment or tools as a consequence of not following this instruction.

! NOTE !

Used for emphasis or information not directly concerned with the surrounding text but of importance to the reader.

PRODUCT CODES AND SERIAL NUMBERS COVERED

The serial numbers used on Grant Aerona Smart Controller consist of a ten digit numerical code.

For example:

1006986828

This serial number can be found on a label attached to the wiring centre.

! CAUTION !

Electric device under voltage!

Before any action related to the power supply (cables connection, device installation etc.), check to ensure the controller is not connected to the mains power. Installation should be done by a person with appropriate electrical qualifications. Improper cable connection could result in controller damage. The controller must not be installed in steamy conditions or exposed to water, such as bath or shower room

CUSTOMER SUPPORT CENTRE

Grant UK provides an online support centre for Heating Professionals and Homeowners to access post-installation care, advice and maintenance support for Grant products. Follow the QR codes below to access your relevant Customer Support Centre.



Homeowner



Professional

SOFTWARE HISTORY

As with any software based solution, the Grant Aerona Smart Controller is subject to updates for its operation and functionality.

To view the software version of an installed Grant Aerona Smart Controller, refer to appendix H.1.2 - How to obtain the UID which also displays the current software/firmware versions.

Alternatively (if registered), visit your ecoNET24 account and select 'DEVICE SETTINGS' and refer to 'CONTROLLER SOFTWARE VERSIONS'

Refer to the table below for manual revisions and their related software versions.

Refer to the Grant UK support hub and the TechBox App for access to Grant UK archive of technical manuals.

Manual revisions & Software versions (R32 & R290)

Manual Revision	Wiring Centre	Touchscreen display
1.0	S002.04	S.002.11
1.1	S002.04	S.002.11
2.0 - 2.1	R290 S023.14	R290 S023.20
	R32 S003.14	R32 S.003.20
2.2	R290 S024.22	R290 S024.25
	R32 S004.22	R32 S.004.26
2.3 - 2.4	R290 S024.24	R290 S024.29
	R32 S004.24	R32 S.004.29



GRANT ENGINEERING (UK) LIMITED

Frankland Road, Blagrove Industrial Estate, Swindon, SN5 8YG

Tel: +44 (0)1380 736920 Fax: +44 (0)1380 736991

Email: info@grantuk.com www.grantuk.com

This manual is accurate at the date of printing but will be superseded and should be disregarded if specifications and/or appearances are changed in the interests of continued product improvement. However, no responsibility of any kind for any injury, death, loss, damage or delay however caused resulting from the use of this manual can be accepted by Grant Engineering (UK) Limited, the author or others involved in its publication.

All goods sold are subject to our official Conditions of Sale, a copy of which may be obtained on application.

© Grant Engineering (UK) Limited. No part of this manual may be reproduced by any means without prior written consent.

Contents

1	INTRODUCTION	5	8	SERVICE SETTINGS	35
1.1	General	5	9	HEAT PUMP PARAMETERS	41
1.2	Safety information	5	10	WI-FI HUB	42
1.3	Information about documentation	5	10.1	General	42
1.4	Storage of documentation	5	10.2	Connection to wiring centre	42
1.5	Conditions of storage and transport	5	10.3	Connection to Internet	43
2	TECHNICAL DATA	6	11	SERVICING	44
2.1	Wiring centre	6	11.1	Component replacement	44
2.2	Touchscreen display	6	11.2	Accessories & spare parts	44
2.3	Product contents	7	11.3	Updating controller software	44
2.4	Additional components	7	12	FAULT FINDING	46
3	INSTALLATION	8	12.1	Alarms	46
3.1	General	8	12.2	Thermostats	46
3.2	Regulations and standards	8	12.3	EcoNET	46
3.3	Touchscreen display	8	13	EC DECLARATIONS OF CONFORMITY	47
3.4	Wiring centre	9	14	HEALTH AND SAFETY INFORMATION	48
3.5	Temperature sensors	9	15	DISPOSAL AND RECYCLING	48
3.6	Connecting pumps	10	15.1	Directive WEEE 2012/19/EU	48
3.7	Connecting 3-port mixing valves	10	16	GUARANTEE	49
3.8	Connecting relays	10		APPENDIX A - WIRED THERMOSTAT	51
3.9	Smart flow sensor	10	A.1	General	51
3.10	Room thermostat connection	10	A.2	Installation	51
3.11	Connecting the Wi-fi Hub	11	A.3	Thermostat panel	51
3.12	Connecting the Modbus	11	A.4	Pairing	52
4	SYSTEM HYDRAULICS	12	A.5	Changing setpoint temperature	52
4.1	Hydraulic Connections	12	A.6	User menu	52
4.2	Installation Pack Summary	12	A.7	Error codes	53
4.3	Hose Kits	12	A.8	Technical data	53
4.4	Pump Over-run protection	12		APPENDIX B - WIRELESS THERMOSTAT AND RECEIVER	54
4.5	Legionella Protection	12	B.1	General	54
4.6	Automatic bypass	12	B.2	Installing wireless receiver	54
4.7	Hydraulic connections - Pack P	13	B.3	Wireless thermostat	54
4.8	Hydraulic connections - Pack Q	14	B.4	Multiple thermostat support	55
4.9	Hydraulic connections - Pack R	15	B.5	Thermostat panel	55
5	ELECTRICAL CONNECTIONS	16	B.6	User menu	55
5.1	Connecting the wiring centre	16	B.7	Memory reset of the wireless receiver	55
5.2	Component connections	16	B.8	Alarms	56
5.3	Power supply failure	16	B.9	Technical data	56
5.4	Wiring centre layout	17		APPENDIX C - 3-PORT MIXER VALVE	57
5.5	Electrical connections - Pack P	18	C.1	General	57
5.6	Electrical connections - Pack Q	19	C.2	3-Port valve body	57
5.7	Electrical connections - Pack R	20	C.3	Motorised actuator	58
6	SYSTEM CONFIGURATION WITH TOUCHSCREEN DISPLAY	21	C.4	Assembly	58
6.1	First switch-on	21	C.5	Mixing valve Wiring	59
6.2	System configuration creator	21	C.6	Water temperature sensor	59
7	OPERATION AND SETTINGS	24		APPENDIX D - HEATING ASSISTANCE	60
7.1	Touchscreen display	24	D.1	General	60
7.2	Smart Controller operation	25	D.2	Wiring	60
7.3	Circuit settings	25	D.3	Legionella protection	60
7.4	Legionella protection	27	D.4	Supplementary heating	61
7.5	Time schedules	27	D.5	Defrost assistance	61
7.6	Heat pump schematic	29		APPENDIX E - SMART FLOW SENSOR	62
7.7	System schematic	29	E.1	General	62
7.8	Circuit control	29	E.2	Installation	62
7.9	User settings menu	32	E.3	Electrical	63
7.10	Stored system settings	32	E.4	Sensor configuration	63
7.11	Secondary circulation	32			
7.12	System controls	33			
7.13	Weather compensation	33			
7.14	Circuit operation	33			
7.15	Screed drying	34			

APPENDIX F - COMMISSIONING CHECKLIST	64
APPENDIX G - AERONA³ (R32)	66
G.1 General	66
G.2 Serial Number	66
G.3 Existing controls	66
G.4 Underfloor heating controls	66
G.5 Connecting the Modbus	66
G.6 Aerona ³ frost protection	67
G.7 Service Alarm	67
G.8 Smart immersion relay	67
G.9 Aerona ³ schematic - Pack P (System)	68
G.10 Aerona ³ schematic - Pack P (Electrical)	69
G.11 Aerona ³ R32 Heat pump parameters	70
APPENDIX H - ECONET	72
H.1 Econet24	72
APPENDIX J - EVOLINK SMART	74
J.1 Evolink smart	74
J.2 Parameters	74
J.3 Operation	75
J.4 Adjusting the EvoLink smart	75
J.5 Heat pump (MHS) override	75
ONLINE RESOURCES	76
NOTES	77

1 Introduction

1.1 GENERAL

The Grant Aerona Smart Controller is intended for controlling a central heating and domestic hot water with a Grant Aerona³ or Aerona 290 heat pump, with applicable differences between the heat pumps identified. The controller may be used in domestic and light commercial applications.

! CAUTION !

This manual is written primarily for use with the Grant Aerona 290 heat pump. Refer to Appendix G for specific information on the Grant Aerona³ heat pumps.

1.2 SAFETY INFORMATION

Requirements concerning safety are listed in particular Sections of this instruction manual. Apart from these it is necessary to fulfil the following requirements:

- The controller should be installed by qualified installer only and in accordance with current Standards and Regulations.
- Before starting the installation, repairs or maintenance and during the execution of any connection works, it is necessary to switch off the mains power supply and make sure that no terminals and electrical wires are live.
- Even after turning off wiring centre terminals it can still be under a dangerous level of voltage.
- The controller should be utilised only in accordance with its intended use.
- Additional measures should be used in order to protect the central heating and DHW system against the results of controller failure or software errors. Particularly control measures which reduce DHW temperature in order to protect users against burns.
- Parameters should be set in accordance to the heating system design.
- The controller is not an intrinsically safe device. It means that in case of failure it can be a source of sparks or high temperature which can cause fire or explosion.
- Modification of the programmed parameters should be made only by the installer.
- Use only in central heating system made in accordance with currently valid regulations.
- Electrical system including the controller should be 3-wired and protected with fuse selected in accordance with used loads.
- The controller components cannot be used with damaged housing.
- Never make any modifications in controller components structure.
- The controller consists of two key elements: Touchscreen display and wiring centre. Any replaced components must be compatible.
- Keep children away from the controller.

1.3 INFORMATION ABOUT DOCUMENTATION

This manual contains important information significant for safety issues for both user and installer. The user should read both parts of the manual to familiarise themselves.

Grant UK are not responsible for any damages caused by failure to follow these instructions.

1.4 STORAGE OF DOCUMENTATION

This installation and operation manual, as well as any other applicable documentation, should be stored in a safe place for future reference.

1.5 CONDITIONS OF STORAGE AND TRANSPORT

The controller cannot be exposed to direct effects of weather, i.e., rain and sunlight. During transport, the device cannot be exposed to vibrations greater than typical for normal road transport.

2 Technical Data

2.1 WIRING CENTRE

Table 2-1: Technical Data

Grant Aeron Smart Controller - Wiring Centre	
Power supply	230V AC, 50Hz
Controller current consumption	0.4 A ³
Maximum rate current	6 (6) A
Protection class	IP 20 ⁴
Ambient Temperature	0 to 50° C
Storage temperature	0 to 65° C
Relative humidity	5 to 85% without water vapour condensation
Outdoor Weather Sensor working range	-40 to 110° C
Measurement accuracy: Water & Outdoor Weather Sensors	±2° C
Wiring centre dimensions	234mm x 225mm x 64mm
Standards	EN 60730-2-9. EN 60730-1
Software class	A, according to EN 60730-1
Installation method	Wall mounted

³ Current consumed only by the controller. Overall current consumption depends on number of devices

⁴ After installing all cable clamps.

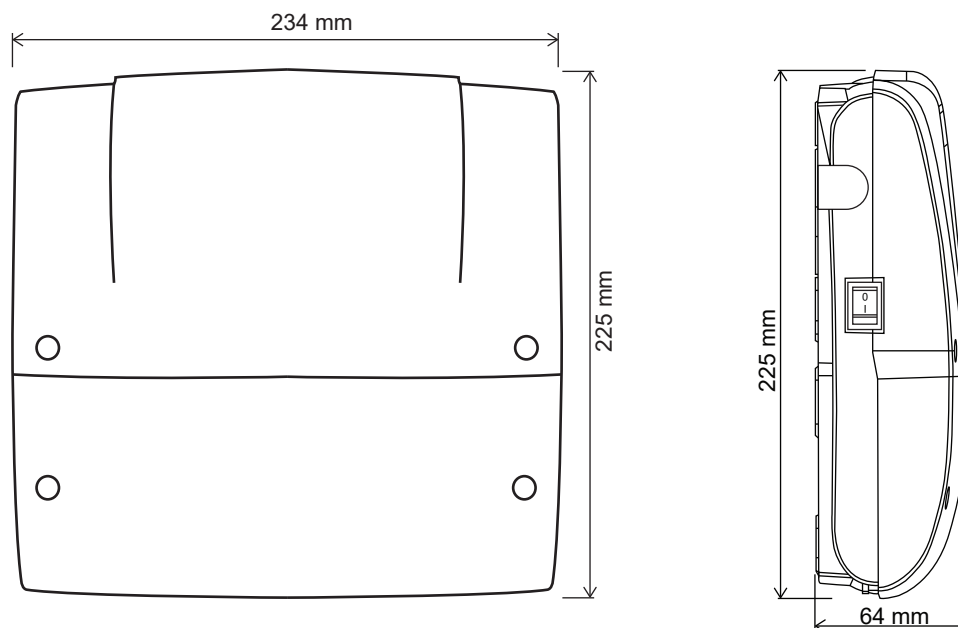

Figure 2-1: Wiring centre dimensions

2.2 TOUCHSCREEN DISPLAY

Table 2-2: Technical Data - Touchscreen Display

Grant Aeron Smart Controller - Touchscreen Display	
Power supply	12V DC directly the Wiring centre
Touchscreen display current consumption	0.15A
Display	Touch screen, graphical 480px x 272px
Protection class	IP 20
Ambient temperature	0 to 50° C
Relative humidity	0 to 65° C
Touchscreen display dimensions	144mm x 97mm x 20mm
Standards	EN 60730-2-9, EN 60730-1
Software class	A, according to EN 60730-1
Installation method	Wall mounted

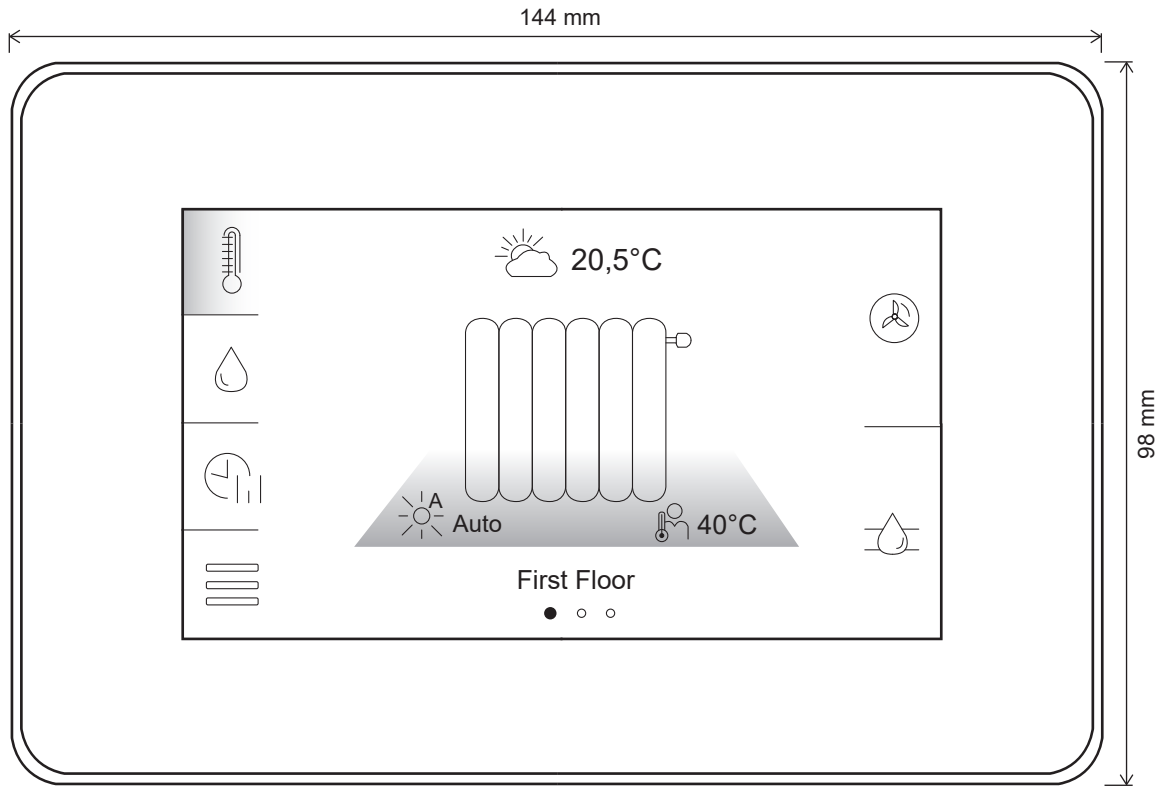

Figure 2-2: Touchscreen display dimensions

2.3 PRODUCT CONTENTS

Table 2-3: Smart Controller Kits - Aerona³ & Aerona 290

	HPIDR32SMART6	HPIDR32SMART10	HPIDR32SMART1317	HP290SMART (All 290 models)
Smart Controller wiring centre	1	1	1	1
Touchscreen display	1	1	1	1
Outdoor weather sensor	1	1	1	1
Water temperature sensors (4m cable)	1	1	1	1
Water temperature sensors (2m cable)	2	2	2	2
Smart flow sensor kit (1m cable)	1	1	1	-
Wi-Fi Hub kit	1	1	1	1
ecoLINK cable	1	1	1	1
Accessory & Fixing pack	1	1	1	1
Flexible Hoses*	2 (22mm)	2 (28mm)	2 (28mm)	-
Isolation Valves*	2	2	2	-

* Only HPIDR32 kits - 22 & 28mm supplied depending on model of heat pump for flow and return connection.

Refer to Section 4.3 for hose kit packs for Aerona 290 installations.

2.4 ADDITIONAL COMPONENTS

Grant UK offer a number of additional components compatible with the Aerona Smart Controller for consideration.

Table 2-4: Additional components

	Part Code
Wireless thermostat (with receiver)	HPIDSMARTWRTR
Wireless thermostat (no receiver)	HPIDSMARTWRT
Wireless thermostat receiver	HPIDSMARTRECEIVER
Wired thermostat	HPIDSMARTHRT
Water temperature sensor with 2m cable*	HPIDSMARTSEN2
Water temperature sensor with 4m cable*	HPIDSMARTSEN4
Immersion Heater Relay	HPIDSMARTIMM

*supplied as part of Aerona Smart Controller installation packs or Controller kits. Refer to Table 2-3 and Section 4

3 Installation

IMMEDIATE CONSIDERATION SHOULD BE GIVEN TO HYDRAULIC (REFER TO SECTION 4) AND ELECTRICAL (REFER TO SECTION 5) CONNECTIONS PRIOR TO INSTALLATION FOR WIRING CENTRE POSITIONING.

3.1 GENERAL

This Section gives details of the installation process for the Grant Aerona Smart controller.

These installation instructions must be read in conjunction with the Grant Aerona air source heat pump installation instructions (provided with the unit).

Before starting to install the Grant Aerona Smart controller please read the Health and Safety information given in Section 14 of these installation instructions.

Similarly, before starting any installation work on the Grant Aerona air source heat pump please read the Health and Safety information given in Section 14 of the Aerona³ & Aerona 290 installation instructions.

3.2 REGULATIONS AND STANDARDS

The installation of the Grant Aerona Smart controller and a Grant Aerona air source heat pump must be in accordance with the following recommendations, as applicable:

- National Building Regulations, e.g. Approved Documents L & G
- Local Bylaws (Check with the Local Authority for the area)
- Water Supply (Water Fittings) Regulations 1999
- MCS Installers Standards (when required, e.g. for installations for the Boiler Upgrade Scheme).
- MIS 3005 - I. The Heat Pump Standard - Installation.
- MIS 3005 - D. The heat pump Standard - Design.
- MCS 020. MCS Planning Standard

The installation should also be in accordance with the latest edition of the following standards and codes of practice:

- BS 7671 and Amendments. Requirements for Electrical Installations. IET Wiring Regulations.
- BS EN 12831. Energy performance of buildings. Method for calculation of the design heat load. Space heating load.
- BS 7593. Code of practice for the preparation, commissioning and maintenance of domestic central heating and cooling water systems.

3.3 TOUCHSCREEN DISPLAY

The touchscreen display is designed to be wall mounted. It must not be installed in steamy conditions such as a bath or shower room. The touchscreen display should be mounted at a height allowing comfortable operation, typically 1.5m above the floor. Refer to Figure 3.1.

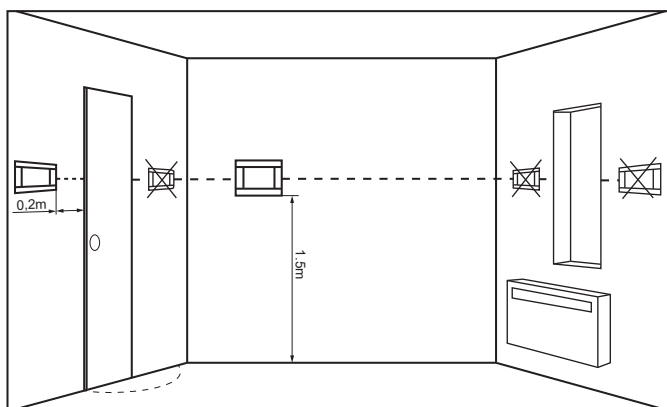

Figure 3-1: Touchscreen display positioning

To reduce measurement disturbances avoid locations exposed to strong sunlight, with poor air circulation, near heating equipment, and directly at the door and windows, typically 200mm from the edge of the door.

! NOTE !

When selecting the cable connecting the touchscreen display with the wiring centre, you must use a cable with single wire resistance lower than 8Ω. Total cable length must not exceed 100m.

3.3.1 FITTING THE TOUCHSCREEN DISPLAY

The touchscreen display installation should be done according to the following guidelines:

1. Detach the mounting plate from the back of the touchscreen display. The plate is attached to the touchscreen with latches. Use a flat screwdriver to detach the plate. (Refer Figure 3-2)
2. Using a sharp tool cut out holes in four places of the cover for the screw terminals. (Refer to Figure 3-3)

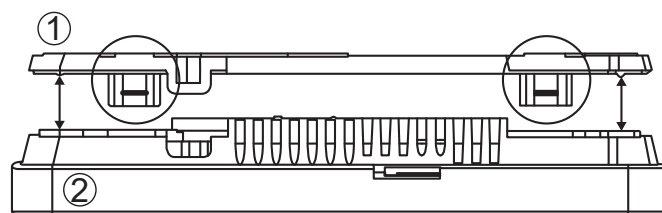

Figure 3-2: Touchscreen display & back plate

3. Connect the cable to the screw terminal as described on the plate. Refer to Figure 3-4. The cable can be recessed in the wall or it can run over its surface - In this case the cable should be additionally placed in the cable channel.

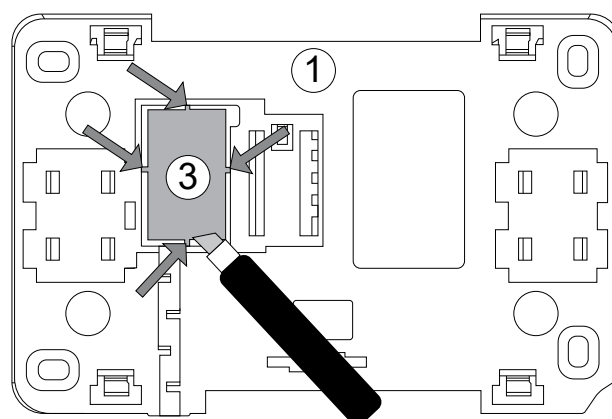

Figure 3-3: Mounting plate cutaway

4. Drill holes in the wall and use screws to fix the mounting plate in the chosen place of the wall, maintaining its proper position (Refer to Figure 3-4)
5. Attach the panel to the mounting plate using latches.

! NOTE !

The touchscreen display connection cable can not be ducted with other electrical cables that are part of the building mains and should not be routed near devices that emit a strong Electromagnetic field

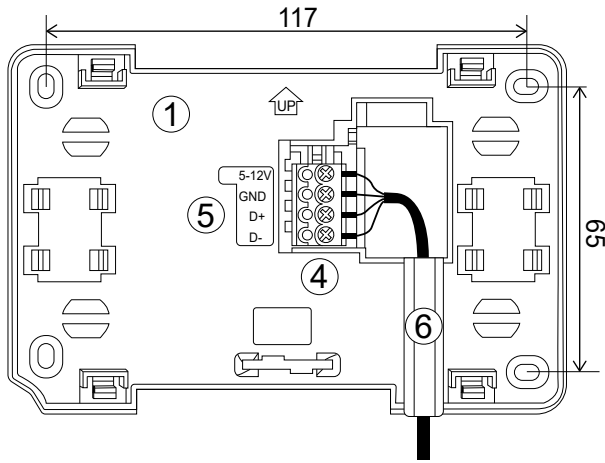

Figure 3-4: Mounting plate wiring

Table 3-1: Touchscreen display & mounting plate

No	Description
1	Touchscreen display mounting plate
2	Touchscreen display
3	Mounting plate cut-away
4	Screw terminal
5	Terminal connection guide
6	Cable Channel

! NOTE !

The touchscreen display, wireless receiver and any wired thermostats used must only be connected to the G1 socket of the wiring centre.

3.4 WIRING CENTRE

The wiring centre should be located in a suitable and neutral position to avoid damage and tampering.

3.4.1 FITTING THE WIRING CENTRE

The wiring centre should be mounted on to a flat surface, e.g., wall.

1. Drill and fit 2 mounting points for the mounting holes provided on the upper Section of the back of the wiring centre. (Refer to Figure 3-5).
2. Slot the wiring centre in place ensuring it is fully down.
3. Remove wiring centre lower front cover (via 2 screws) and mark position of lower 2 holes. (Refer to Figure 3-5)
4. Remove wiring centre, drill and fit wall plugs.
5. Set wiring centre back in position and fix controller with lower holes to secure in final position.
6. Ensure the wiring centre is securely in place and replace lower controller case front.

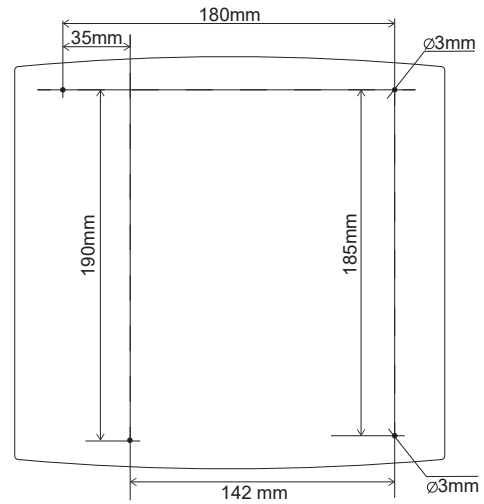

Figure 3-5: Wiring centre fixing centres

! NOTE !

Ensure to leave adequate access to the ON/OFF switch if the left side of the wiring centre is close to a side wall.

3.5 TEMPERATURE SENSORS

The Smart Controller should be used only with the Grant supplied Outdoor and Water temperature sensors. At least one Water temperature sensor is necessary to activate the controller and will be required on any mixing circuits utilised.

If not required on space heating circuits, the water temperature sensors can be deactivated from the Smart controller. Refer to 7.12.2 - CIRCUIT TEMP. FROM PUMP RETURN', which will cause all active space heating circuits to read the temperature from the return of the heat pump as the active water temperature (Circuits 2 and 3 only).

We recommend the water temperature sensors be fitted as this will provide real-time and historical performance data via the ecoNET platform (if connected).

3.5.1 WATER TEMPERATURE SENSORS

The water temperature sensors should be installed in an area of the system relevant to their function. For heating circuits the most suitable location would be after controlled valves on the circuit flow to give the most accurate reading for the circuit.

Insulate the sensors affixed to the external surface of the pipe using thermal insulation covering the sensor together with the pipe. (Refer to Figure 3-6)

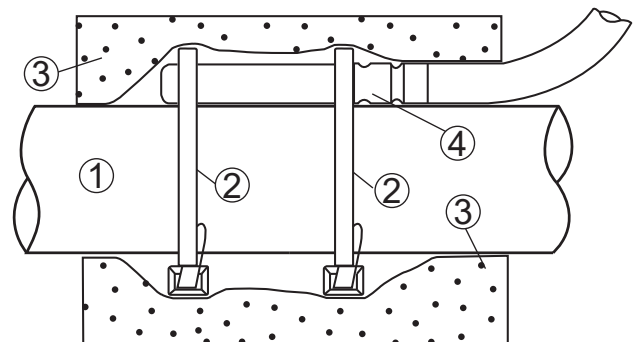

Figure 3-6: Circuit temperature sensor fitting

Table 3-2: Temperature Sensor installation

No	Description
1	Flow Pipe
2	Zip tie
3	Thermal insulation
4	Water Temperature sensor

3.5.2 OUTDOOR WEATHER SENSOR

The Outdoor weather sensor is the only external sensor to be used with the Grant Aerona Smart Controller. It should:

- Be fixed to the coldest wall in the building, usually a north wall under the roof.
- Not be exposed to direct sunlight.
- Be fixed between 1.5 and 2m above the ground and in a distance of at least 1.5m from windows, chimneys and other heat sources which could interrupt the temperature measurement.
- Use a connecting cable with a cross section of at least 0.5mm² and length of 25m. Polarity of wires is not important.

To fasten the external sensor to the wall.

1. Remove the front of the sensor housing. (Refer to Figure 3-7).
2. Position the rear part of the housing against the wall, mark and drill fixing holes.
3. Insert the supplied wall plugs, place the housing back into position and secure in place with the screws.

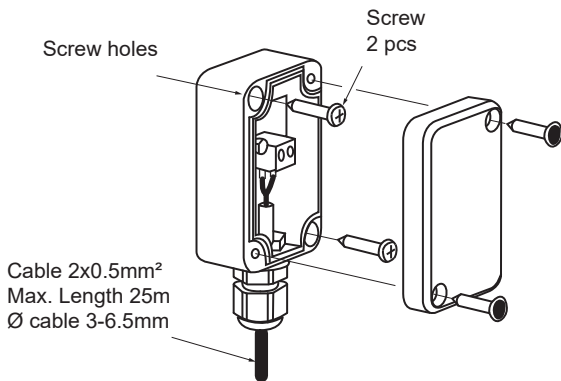

Figure 3-7: Outdoor weather sensor

3.5.3 TEMPERATURE SENSOR RESISTANCE

The accuracy of the temperature sensors can be checked by measuring their resistance at a given temperature. In case of significant differences between measured resistance value and values in Table below, the sensor should be replaced. (See Table 3-3)

Table 3-3: Temperature/Resistance chart

Water and Outdoor Weather sensors (10kΩ NTC)

Temp (°C)	Nom (Ω)
-30	175200
-20	96358
-10	55046
0	32554
10	19872
20	12488
30	8059
40	5330
50	3605
60	2490
70	1753
80	1256
90	915.4
100	677.3
110	508.30
120	386.60

3.6 CONNECTING PUMPS

Electrical connections from the circuit pumps to the controller should be according to the electrical schematics. Refer to Section 4.

3.7 CONNECTING 3-PORT MIXING VALVES

The Grant Aerona Smart Controller should only be used with valve actuators equipped with limit switches and the 3-Port mixing valves can only be fitted as part of an adjustable circuit. Refer to Appendix C for further details on 3-Port mixing valves.

A water temperature sensor will also need to be installed after the mixing valve to measure the mixed water flow temperature for the circuit.

3.8 CONNECTING RELAYS

Relays for Anti-Legionella, defrost assistance & supplementary heating from a volumiser, low loss header and a DHW cylinder can be used in conjunction with the Grant Aerona Smart controller.

They are to be connected via H1 (volumiser or low loss header) or H2 (DHW Cylinder) as these terminals are assigned to specific functions within the Smart Controller software.

Grant UK can supply the Grant Smart Immersion relay to operate external heaters or devices. Refer to Appendix D for further guidance on wiring specifics for Heating Assistance.

3.9 SMART FLOW SENSOR

The Grant smart flow sensor monitors the return flow rate to the Aerona³ heat pump to allow calculation of the COP within the Grant Aerona Smart controller. Refer to Appendix E for installation and configuration requirements.

Grant UK recommend the Grant Smart flow sensor be installed internally on the primary circuit return to the heat pump.

If installing externally, ensure to encase to protect the flow sensor from both the elements and external interference.

! NOTE !

Ensure to refer to Appendix E.2 for information on correct placement of the flow sensor within the installed system.

The Grant smart flow sensor is not required for Grant Aerona 290 heat pump installations.

3.10 ROOM THERMOSTAT CONNECTION

For optimum operation of the Grant Aerona Smart Controller each circuit within the system should have an individual thermostat assigned to it.

The room thermostats connect to the wiring centre and can utilise the weather compensation function to automatically adjust the flow temperature within the circuit to provide a consistent room temperature. The required temperature is set on the room thermostat of the circuit concerned.

It is possible to use the touchscreen as a room thermostat.

3.10.1 ROOM THERMOSTAT WIRING

The Grant Aerona Smart controller can support multiple wired room thermostats (including the touchscreen display). Ensure that the correct polarity of the connections are respected when wiring the room thermostats/touchscreen display in parallel to the wiring centre. (Refer to Figure 3-8).

With the connections made you will need to pair and assign the room thermostats with their own address.

See Appendix A for installation and operation guidance.

! CAUTION !

Maximum length of wires should not exceed 30m. This length may be longer if the wires used have cross-section exceeding 0.5 mm².

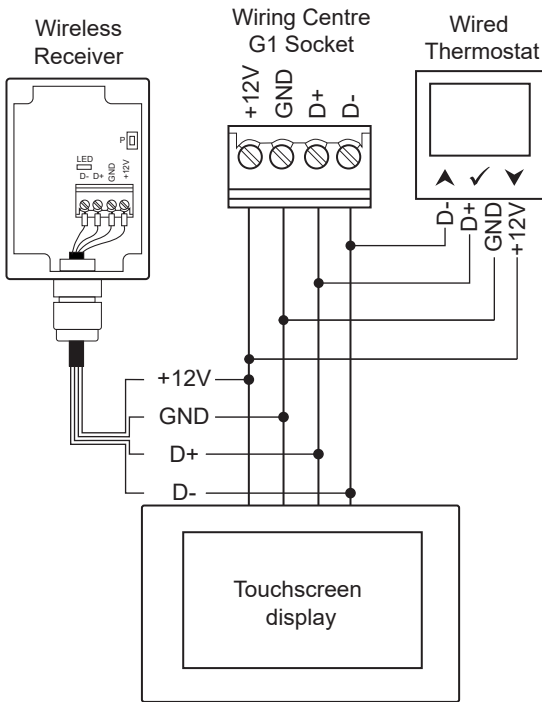

Figure 3-8: Wired and Wireless wiring schematic

3.10.2 WIRELESS ROOM THERMOSTAT

Connecting a wireless room thermostat requires a wireless receiver to be connected to the G1 socket, in the same fashion as the wired thermostat, and the thermostat(s) paired to the wireless receiver. The wireless receiver can support up to 3 wireless thermostats.

See Appendix B for Installation and operation guidance.

! NOTE !

Close attention must be paid to the 4 connections (+12V, GND, D+ and D-). Ensure they match to corresponding wires from touchscreen display. (+12V is also referenced as VCC).

3.11 CONNECTING THE WI-FI HUB

The Wi-Fi hub should be connected:

- between the 3G USB socket and the G3 socket of the wiring centre using the ecoLINK cable supplied. Refer to Section 10 for installation and user guidance.
- between the micro-usb power input socket and a mains power supply with the USB plug adapter supplied with the Wi-Fi hub .

3.12 CONNECTING THE MODBUS

The Grant Aerona Smart controller communicates with the Aerona 290 heat pump via a Modbus connection, which is made between Terminals H2(+) & H1(-) of the heat pump and the G2 socket of the Grant Aerona Smart controller.

This **MUST** be Shielded cable (Cat 5/6 is acceptable) and the shield ground connected at the heat pump only, stripping back shielding in the Aerona Smart Controller wiring centre. Ensure polarity of connections are matched from the Aerona heat pump to the G2 socket. Refer to Figure 3-9 and your supplied Grant Aerona 290 manual.

For Grant Aerona³ R32 heat pumps refer to Appendix G for further information.

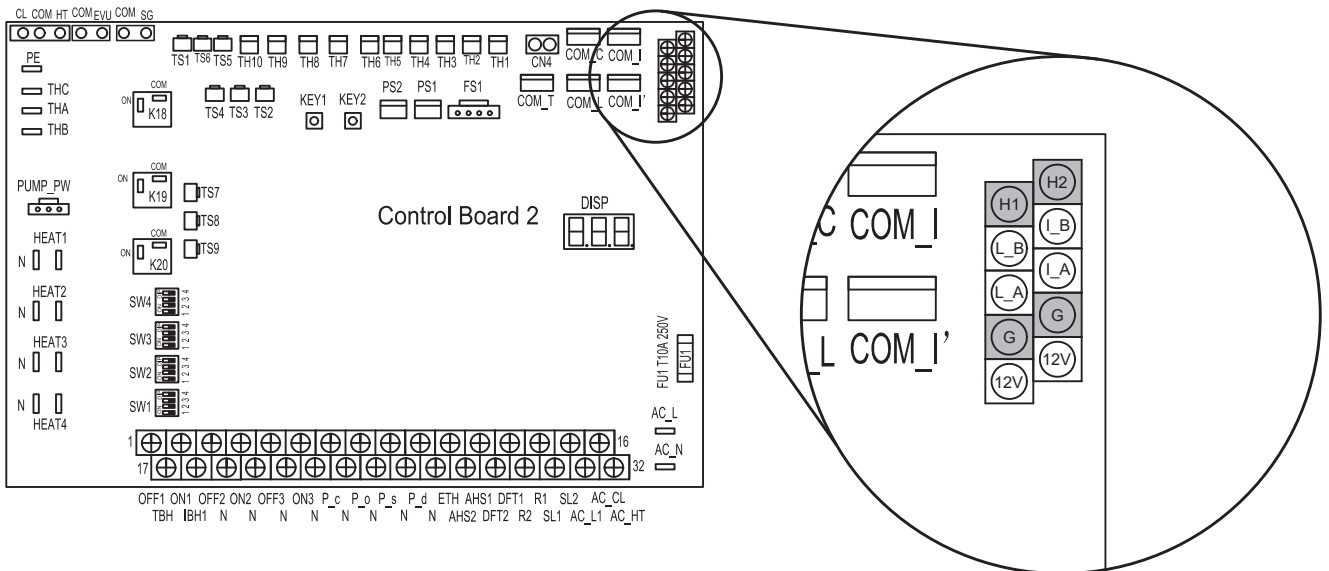

Figure 3-9: Modbus connection to Grant Aerona R290 Heat pump

3.13 CABLES

Grant Engineering UK recommend to use cable with a cross section of at least 0.5mm² for extending 230V electrical circuits, ensuring that the cable is rated for the appropriate voltage and current requirements.

For low-voltage wiring (such as the touchscreen display, smart flow sensor and wired thermostat connections), Cat 5/6 shielded cables should be used, as they are specifically designed for reliable performance in low-voltage applications.

! NOTE !

If Cat 5/6 cables are not shielded, take care to ensure that these cables are NOT running alongside any 230V cables to avoid signal interference.

Always ensure the cables meet the necessary standards for safety and performance specific to the intended use.

4 System Hydraulics

4.1 HYDRAULIC CONNECTIONS

The Grant Aerona Smart controller can be utilised in a number of ways via the Smart controller configuration creator and settings configuration.

! NOTE !

All enclosed hydraulic schematics demonstrate concept installations using Grant Aerona 290 heat pump installation packs. Refer to Online resources for a link to the Grant UK schematics library for further concept drawings for the Aerona 290 and Aerona³.

Refer to the DOC 0204 - Grant Aerona 290 Installation and Operating instructions provided for further information regarding sealed system & DHW considerations.

Refer to the DOC 0136 - Grant Aerona³ Installation and Operating instructions provided for further information regarding sealed system & DHW considerations.

Refer to Section 5.5, 5.6 and 5.7 for corresponding electrical connection drawings.

4.2 INSTALLATION PACK SUMMARY

4.2.1 INSTALLATION PACK P

Installation Pack P - Direct S-Plan with non pre-plumbed cylinder.

Table 4-1: Installation Pack P

Order code: HPIDPACKP

Flex-Foot Kit

Mag One Filter

18L System Kit

32A Isolator

Refer to Section 4.6 for Hydraulic schematic.

4.2.2 INSTALLATION PACK Q

Installation Pack Q - Open Loop Direct using 3-Port Diverter and Mixing Valve with non pre-plumbed cylinder.

Table 4-2: Installation Pack Q

Order code: HPIDPACKQ

Flexi-Foot Kit

Mag One Filter

18L System Kit

32A Isolator

28mm 3 Port Diverter Valve

22mm 3 Port Mixing Valve

Refer to Section 4.7 for Hydraulic schematic.

4.2.3 INSTALLATION PACK R

Installation Pack R - Open Loop Direct using 3 Port Diverter Valve with non pre-plumbed cylinder.

Table 4-3: Installation Pack R

Order code: HPIDPACKR

Flexi-Foot Kit

Mag One Filter

18L System Kit

32A Isolator

28mm 3 Port Diverter Valve

Refer to Section 4.8 for Hydraulic schematic.

4.3 HOSE KITS

Grant UK offer two types of hose kit for primary circuit connection in only Aerona 290 installations.

- **HPHOSEKIT** - This kit comes with 2 x uninsulated flexi hoses and 2 x 28mm ball valves.
- **HPHOSEKITPRO** - This kit comes with 2 flexi hoses pre-fitted with primary pro insulation and 2 x 28mm long stem ball valves and sealant.

For Grant Aerona³ installations the flexi hoses and isolation valves are supplied with the Aerona Smart Controller kit.

4.4 PUMP OVER-RUN PROTECTION

The Grant Aerona Smart controller works in conjunction with the Aerona heat pump to ensure there is no dead heading of the circulating pump at the end of:

- Space Heating & DHW demands
- Defrost cycles
- Frost protection cycles

When any of the above functions end and no other demands are to run, the circulating pump will complete any overrun protection built into the heat pump before going into stand-by. (Refer to supplied installation instructions for the heat pump in question for further details)

To accommodate the flow during this time, the Smart Controller will open any configured space heating valves until the circulating pump stops, after which the valves will be closed.

4.5 LEGIONELLA PROTECTION

The Grant Aerona 290 range of heat pumps offer a higher output flow temperature (similar to a conventional Gas or Oil boiler) and can achieve the temperatures required to heat the DHW cylinder sufficiently to protect against Legionella bacteria without the need for additional support from electric immersion heaters when compared to the Aerona³.

If required, a Grant Smart Immersion relay can be installed to assist the Grant Aerona 290. Refer to Appendix D for further information.

For Grant Aerona³ installations, refer to Appendix G for further details.

For information on enabling and configuring Legionella protection, refer to Section 7.4.

4.6 AUTOMATIC BYPASS

The Grant Smart controller has a pump overrun protection function that will automatically open the motorised valve(s) to the heating circuit(s) to avoid deadheading the heat pump circulator during the overrun period following space heating demands (including Defrost and Anti-freeze protection routines) and thus does not require an automatic system bypass to be fitted.

However, some systems will still require an automatic system bypass to be fitted, where the heating system has high resistance circuits or where circuits cannot always allow flow when the pump over-run protection is active, such as:

- Underfloor heating installation where the loops are fitted with actuators/valves.
- Underfloor heating installations with direct flow/return manifold connections rather than a 'close coupled T' connection that gives hydraulic separation.
- Where all radiators are fitted with TRVs and there is no radiator fitted with two lockshield valves i.e. always open.

4.7 HYDRAULIC CONNECTIONS - PACK P
 Grant UK Drawing Number: HPCS-P001SR290

Item	Description
1	Aerona 290 ASHP
2	Flexible hoses & Isolation Valves ³
3	Isolation valve
4	Anti-Vibration Mounts ²
5	Grant Mag One Duo magnetic filler kit ²
6	Smart controller wiring centre ¹
7	Touchscreen display ¹
8	Room thermostat
9	Motorized 2-Port valve (DHW)
10	Automatic air vent
11	Grant QR2 DHW cylinder
12	Cylinder temperature sensor ¹
13	Cylinder immersion heater
14	Immersion heater relay - Optional
15	Drain point
16	Removable filling loop ²
17	Double check valve ²
18	Pressure gauge ²
19	Expansion vessel ²
20	Tundish
21	Pressure relief valve ²
22	Thermostatic Radiator valve
23	Motorized 2-Port valve (Radiator circuit)
24	Motorized 2-Port valve (UFH circuit)
25	Thermostatic mixing valve
26	UFH pump
27	UFH manifold
28	Water temperature sensor ¹ - Optional
29	Outdoor weather sensor ¹
30	Automatic Bypass - Optional ¹

¹ Supplied with the HP290SMART Smart Controller Kit
² Supplied with the HPIDRPACKP
³ Available hose kits: HPHOSEKIT or HPHOSEKITPRO
 * Refer to installation manuals for further details

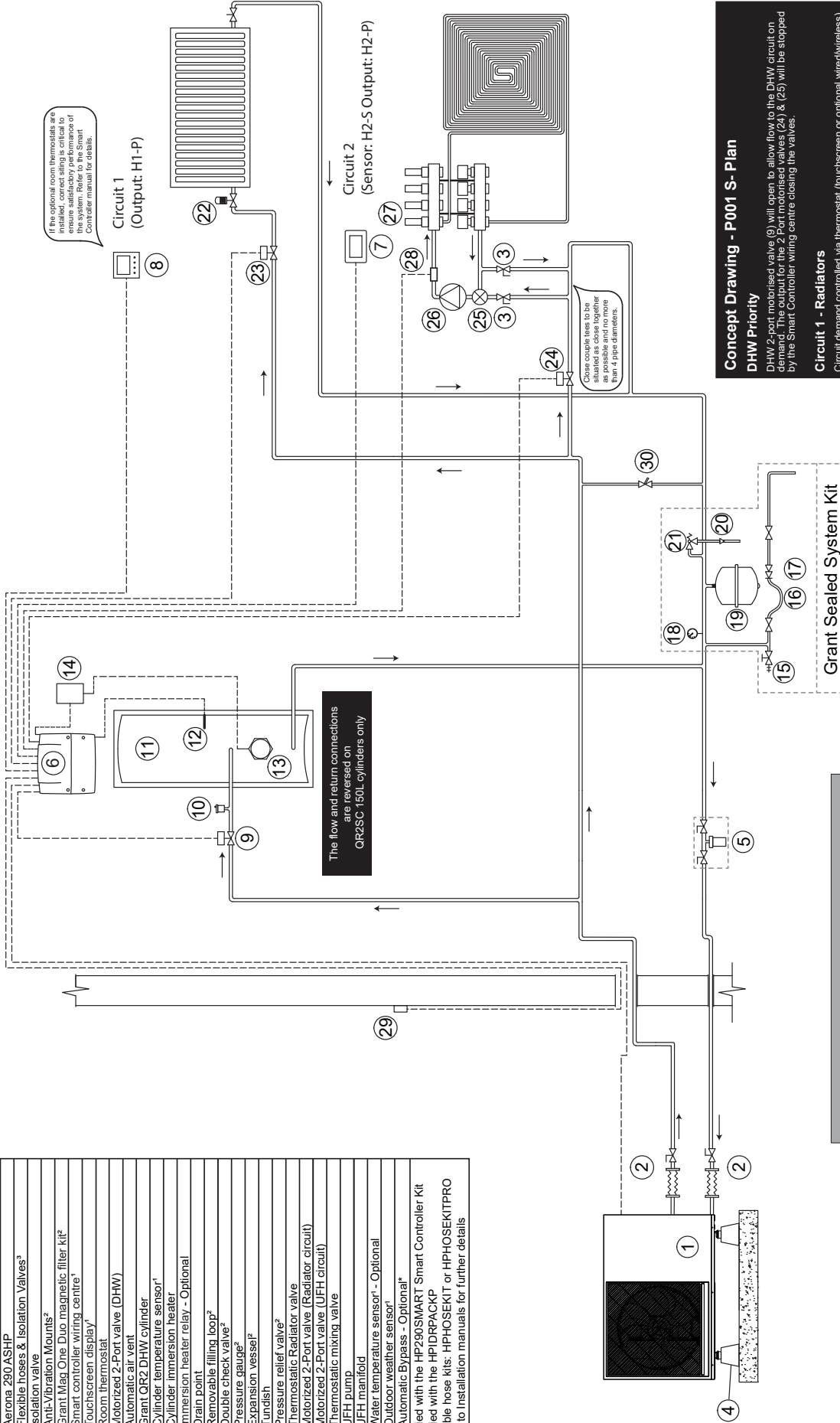

If the optional room thermostats are installed, correct siting is critical to the system. Refer to the Smart Controller manual for details.

Circuit 1
 (Output: H1-P)

Circuit 2
 (Sensor: H2-S Output: H2-P)

Concept Drawing - P001 S-Plan
DHW Priority
 DHW 2-port motorised valve (9) will open to allow flow to the DHW circuit on demand. The output for the 2 Port motorised valves (24) & (25) will be stopped by the Smart Controller wiring centre closing the valves.
Circuit 1 - Radiators
 Circuit demand controlled via thermostat (touchscreen or optional wired/wireless).
 2 port motorised valve (23) operation is managed by the Smart controller using THERMOSTATIC PUMP BLOCKADE function.
Circuit 2 - UFH
 Circuit demand controlled via thermostat (touchscreen or optional wired/wireless).
 2 port motorised valve (24) and circulating pump (26) operation is managed by the Smart controller using THERMOSTATIC PUMP BLOCKADE function.
 Flow temperature into UFH manifold (28) is managed via thermostatic mixing valve (25) in case Circuit 1 low temperature is too high for UFH. No actuators fitted on UFH manifold

! NOTE !
 "Pump Over-run" protection does not always negate the need for an automatic bypass. Refer to installation manuals for further information.

! NOTE !
 Please refer to the Aerona R290 ASHP installation instructions for details of the flow and return connections at the heat pump.

! NOTE !
 This system schematic should be read in conjunction with the Grant Aerona Smart Controller installation instructions and wiring diagram HPCS-P001ER290.

4.9 HYDRAULIC CONNECTIONS - PACK R
 Grant UK Drawing Number: HPCS-R001SR290

Item	Description
1	Aerona 290
2	Flexible hose & Isolation valve ³
3	Isolation valve
4	Anti-Vibration Mounts ²
5	Grant 'Mad One Duo' magnetic filter ²
6	Smart Controller wiring centre ¹
7	Touchscreen display ¹
8	Automatic air vent
9	Grant QR2 DHW cylinder
10	Cylinder temperature sensor ¹
11	Cylinder immersion heater
12	Immersion heater relay - Optional
13	Drain point
14	Removable filling loop ²
15	Double check valve ²
16	Pressure gauge ²
17	Expansion vessel ²
18	Tundish
19	Pressure relief valve ²
20	3-Port Motorised diverter valve ²
21	Thermostatic Mixing Valve
22	UFH Pump
23	UFH Manifold
24	Water Temperature Sensor ¹ - Optional
25	Outdoor Weather Sensor ¹
26	Room thermostat - Optional

¹ Supplied with the HP290SMART Smart Controller Kit
² Supplied with HPIDPACR
³ Available hose kits: HPHOSEKIT or HPHOSEKITPRO

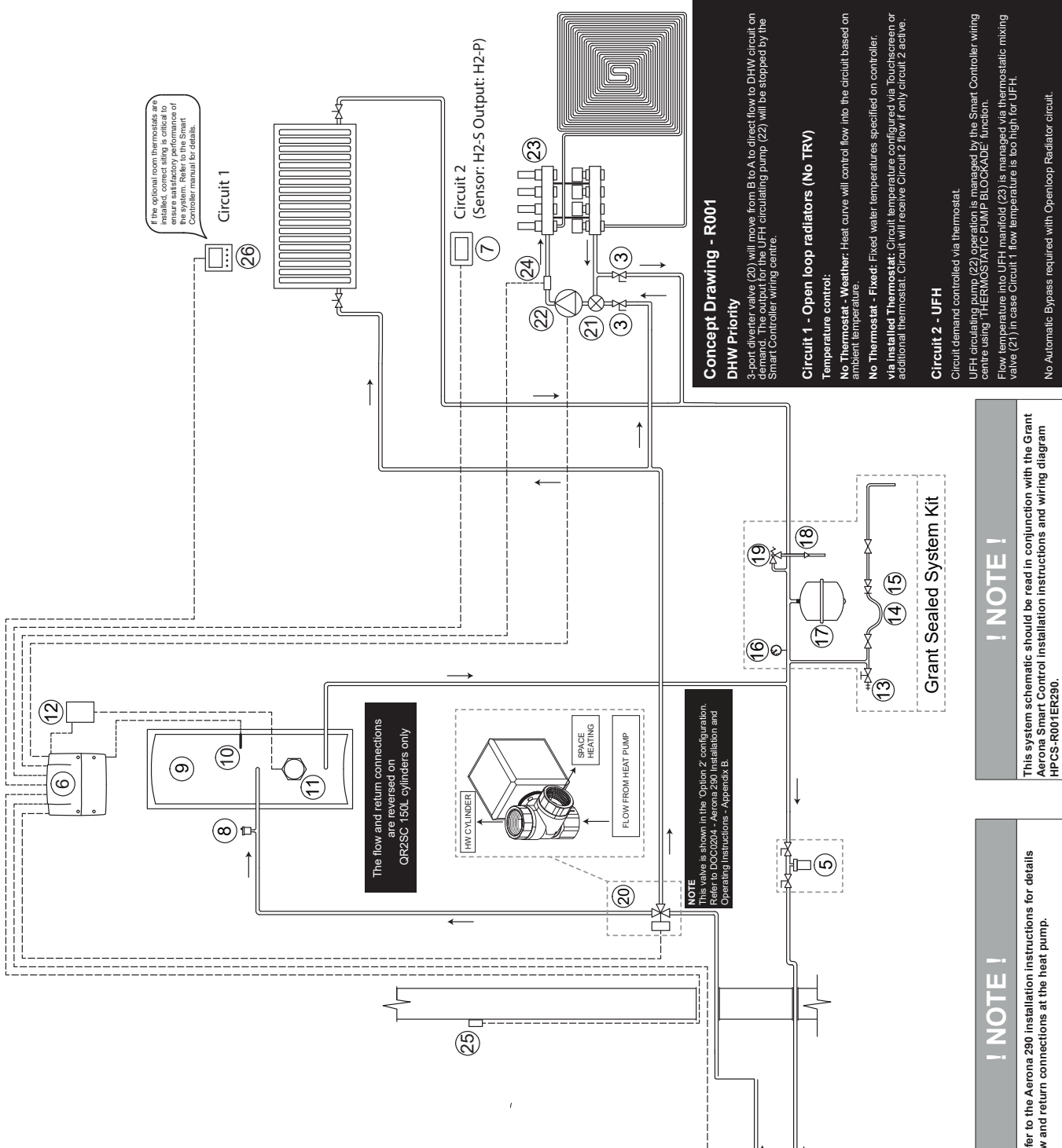

Concept Drawing - R001

DHW Priority
 3-port diverter valve (20) will move from B to A to direct flow to DHW circuit on demand. The output for the UFH circulating pump (22) will be stopped by the Smart Controller wiring centre.

Circuit 1 - Open loop radiators (No TRV)
Temperature control:
 No Thermostat - Weather: Heat curve will control flow into the circuit based on ambient temperature.
 No Thermostat - Fixed: Fixed water temperatures specified on controller.
 Via installed Thermostat: Circuit temperature configured via Touchscreen or additional thermostat. Circuit will receive Circuit 2 flow, if only circuit 2 active.

Circuit 2 - UFH
 Circuit demand controlled via thermostat.
 UFH circulating pump (22) operation is managed by the Smart Controller wiring centre using 'THERMOSTATIC PUMP BLOCKADE' function.
 Flow temperature into UFH manifold (23) is managed via thermostatic mixing valve (21) in case Circuit 1 flow temperature is too high for UFH.

No Automatic Bypass required with Openloop Radiator circuit.

! NOTE !

This system schematic should be read in conjunction with the Grant Aerona Smart Control installation instructions and wiring diagram HPCS-R001ER290.

! NOTE !

Please refer to the Aerona 290 installation instructions for details of the flow and return connections at the heat pump.

5 Electrical Connections

5.1 CONNECTING THE WIRING CENTRE

The wiring centre is to be powered with 230V AC/50 Hz voltage. The electrical installation should be:

- Fused at 3A and earthed,
- Cable size to be 0.75mm² - 1mm².
- In accordance with current regulations, must be protected with a residual current protection device (RCD) with a rating In=30mA.

! WARNING !

All electrical scheme components should be connected only by qualified persons in accordance with applicable regulations. Follow safety precautions to prevent electrocution.

! WARNING !

After the wiring centre is turned off dangerous voltage on terminals may still be present. Before removing cover, disconnect the main power supply and use a Multimeter to check for voltage on terminals and leads.

For safety reasons, the wiring centre must be connected to a fused 230V AC power supply, with the sequence of connecting the live (L) and neutral (N) wires. Make sure that the L and N conductors are not crossed within the building's electrical system, e.g., in an electrical socket or junction box.

5.1.1 ELECTRICAL CONNECTIONS

All wiring connections should be made to the corresponding terminals on the pluggable terminal blocks supplied in the accessory and fixing pack.

1. Remove the terminal cover from the wiring centre housing. Refer to Figure 5-2.

! NOTE !

Isolate any incoming voltages on connections before removing the wiring centre cover beginning to connect to the wiring centre.

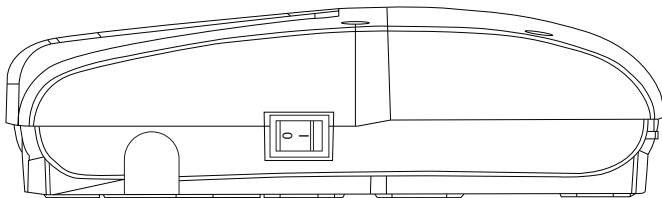

Figure 5-1: Power switch

2. Connect L & N wires of the supply to Terminals 1 & 2. Refer to Figure 5-3 for wiring centre terminal diagram.

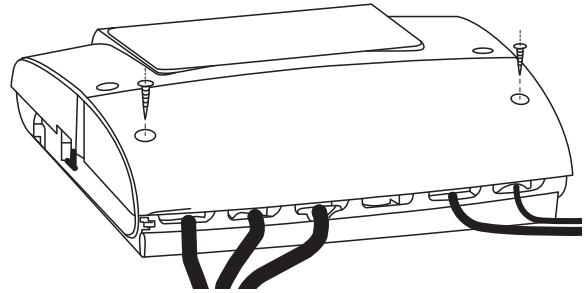

Figure 5-2: Wiring centre terminals cover

3. Connect the earth wire to the earth terminal strip inside the wiring centre housing.
4. Arrange the wires to prevent damaging the insulation by cutting it with cover edges or screws securing the cover.
5. Secure all cables using the cable clamps to prevent loosening due to any mechanical stress.

! WARNING !

The maximum length of the exposed wires extending from the outer cable sheath should not exceed 50mm. Connection cables should not be on contact with surfaces that exceed nominal operating temperature of 50°C.

! CAUTION !

All cable clamps must be fitted (even if not needed) to maintain IP20 ingress protection.

! NOTE !

The wiring centre cover should always be in place before connecting the electrical supply.

5.2 COMPONENT CONNECTIONS

Electrical components of the planned system are to be connected to the wiring centre of the Grant Aerona smart controller. Refer to Section 5.4 for wiring centre layout.

With the adjustable circuits, mixing needs a water temperature sensor connected to monitor the mixed water entering the circuit to adjust accordingly. Table 5-1 displays the relation between the individual heating circuit and its associated component terminals.

Table 5-1: Circuit component connections

Heating Circuit	Pump/Valve	Mixer	Water sensor
1	H1-P	None	None
2	H2-P	H2-M	H2-S
3	H3-P	H3-M	H3-S

Refer to 5.5, 5.6 & 5.7 for example pack wiring schematics. For any further guidance on device connections or schematic drawings, please contact Grant UK.

5.2.1 SWITCH RELAYS

The Aerona Smart controller contains a number of switch relays for remote activation of various components. Any utilised switch relays must be externally protected with an adequate fuse. Refer to Table 5-2.

5.3 POWER SUPPLY FAILURE

In case of power supply failure, the controller returns to the work mode in which it was working previously when the power supply is restored.

5.4 WIRING CENTRE LAYOUT

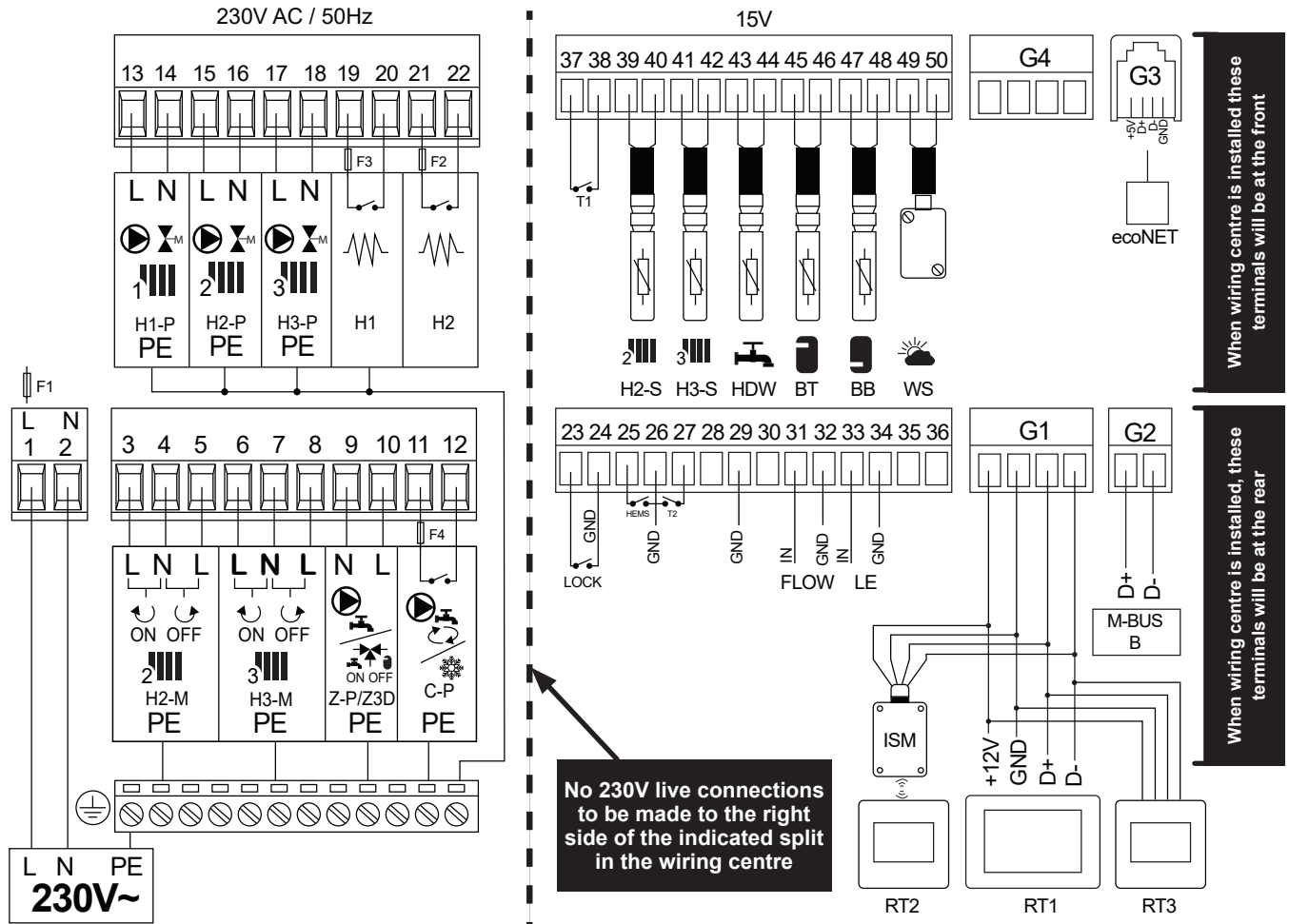

Figure 5-3: Wiring centre - Terminals

Table 5-2: Wiring Centre Terminals

Label	Terminal Numbers	Description
230V ~	1 & 2	Mains Live and Neutral
H2-M	3, 4 & 5	Circuit 2 Mixing valve - 2 x 230V Lives (ON and OFF) and Neutral
H3-M	6, 7 & 8	Circuit 3 Mixing Valve - 2 x 230V Lives (ON and OFF) and Neutral
Z-P/Z3D	9 & 10	DHW Pump/3-Port Diverter Valve
C-P	11 & 12	Secondary Circulation Switched Relay (must be Externally fused 'F4')
Flow	31 & 32	Flow sensor I/O & Ground
LE	33 & 34	Electricity Meter or EvoLink Smart PWM feedback (when AHS enabled)
G1	Terminal Set	Touchscreen & Thermostat connection terminals (RT1, RT2, RT3)
G2	M-BUS	Modbus connection to the Aeraona Heat pump.
G3	G3 Socket	Connection port for ecoNET cable
G4	Terminal Set	+12V, Ground, D+, D-
H1-P	13 & 14	Circuit 1 230V Switched Live and Neutral
H2-P	15 & 16	Circuit 2 230V Switched Live and Neutral
H3-P	17 & 18	Circuit 3 230V Switched Live and Neutral
H1	19 & 20	Switch for Immersion Relay (Back-up heater - must be Externally fused 'F3')
H2	21 & 22	Switch for Immersion Relay (DHW Cylinder - must be Externally fused 'F2')
H2-S	39 & 40	Circuit 2 Water temperature sensor
H3-S	41 & 42	Circuit 3 Water temperature sensor
HDW	43 & 44	DHW Cylinder Water temperature sensor
BT	45 & 46	Buffer Upper Water temperature sensor for Circuit 1 or Boiler Flow sensor (when AHS enabled)
BB	47 & 48	Buffer Lower/Low Loss Header temperature sensor
WS	49 & 50	Outdoor Weather sensor
T1	37 & 38	External Volt-free switch or EvoLink flow sensor (when AHS enabled)
T2	26 & 27	External Volt-free switch for Circuit 2 or 3
LOCK	23 & 24	External Volt-free switch for 'Heat Pump lock'. (Refer to Section 8)
HEMS	25 & 26	Not used

5.5 ELECTRICAL CONNECTIONS - PACK P

Grant UK Drawing Number: HPCS-P001ER290

Notes: Some Neutral and Earth connections have been excluded for clarity.

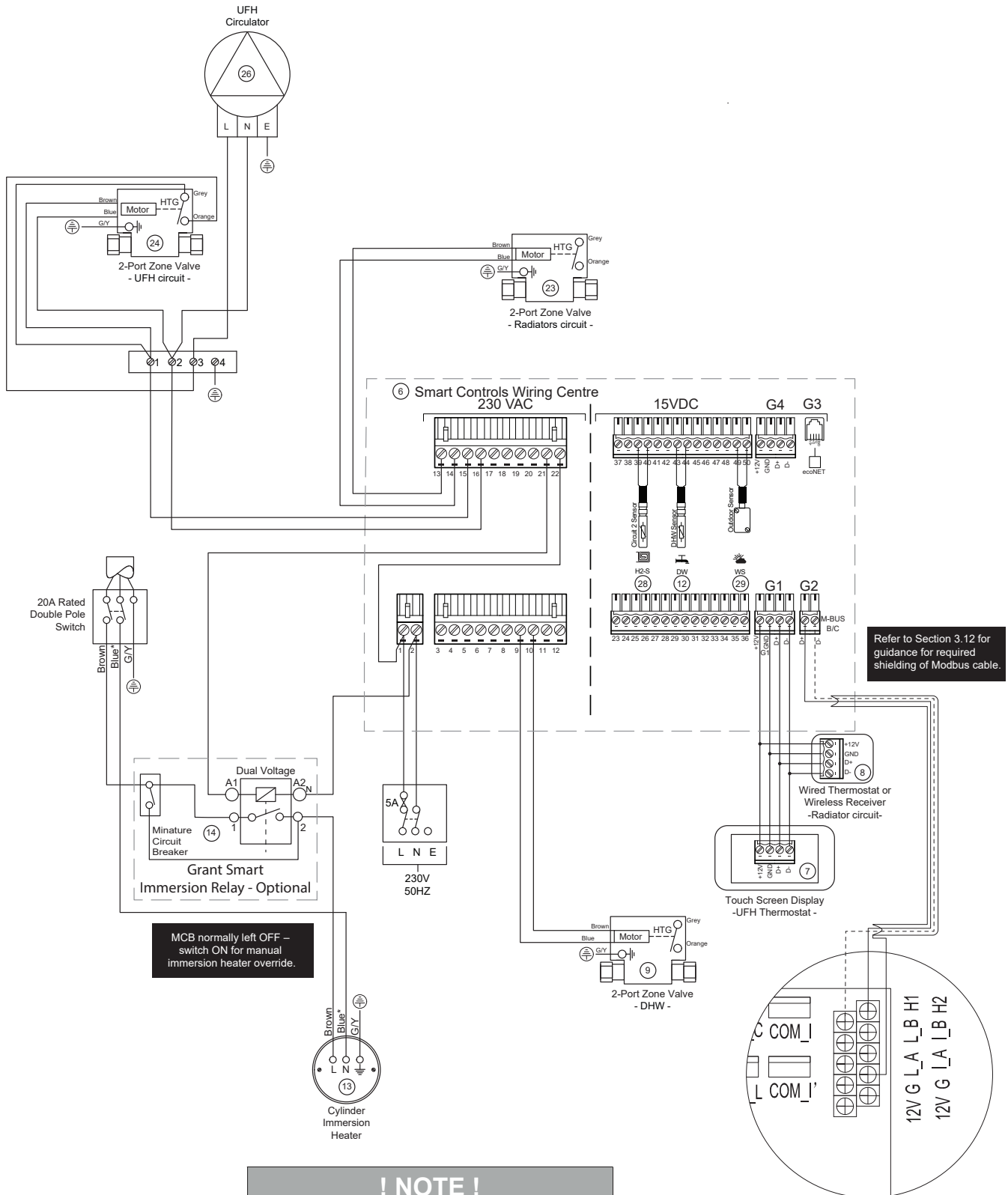

Refer to Section 3.12 for guidance for required shielding of Modbus cable.

MCB normally left OFF – switch ON for manual immersion heater override.

! NOTE !
Cable shielding must be connected to the ground at the heat pump only when connecting the modbus cable.

! NOTE !
*Please ensure that neutrals are derived from the same supply to prevent spurious MCB/RCD trips.

! NOTE !
This wiring diagram should be read in conjunction with the Grant Aeron 290 Smart Controls installation instructions and system schematic HPCS-P001SR290.

① Grant Aeron 290 Hydraulic PCB

5.6 ELECTRICAL CONNECTIONS - PACK Q

Grant UK Drawing Number: HPCS-Q001ER290

Notes: Some Neutral and Earth connections have been excluded for clarity.

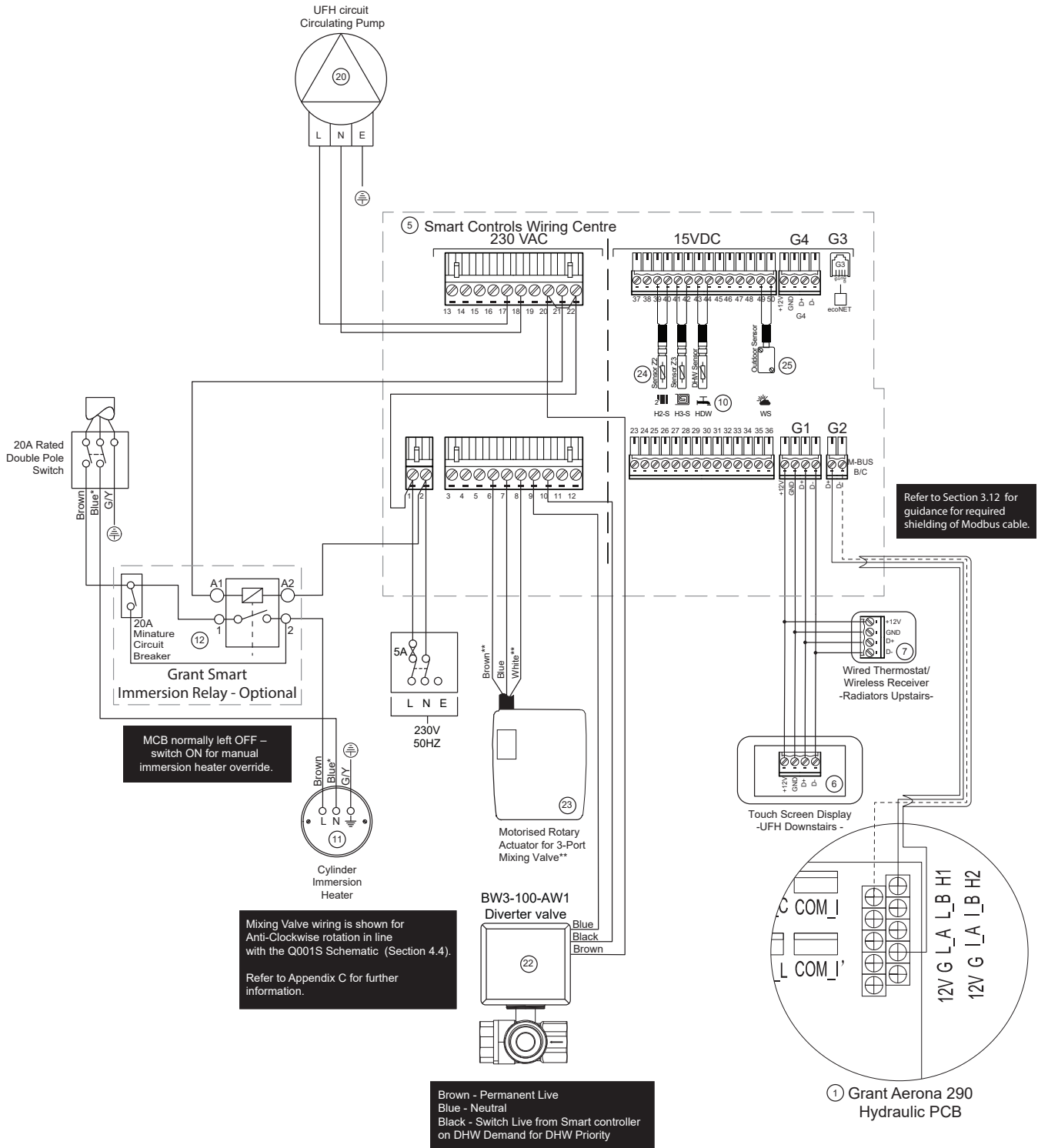

! NOTE !

Cable shielding must be connected to the ground at the heat pump only when connecting the modbus cable.

! NOTE !

*Please ensure that neutrals are derived from the same supply to prevent spurious MCB/RCD trips.

! NOTE !

This wiring diagram should be read in conjunction with the Grant Aeron Smart Controls installation instructions and system schematic HPCS-Q001SR290.

5.7 ELECTRICAL CONNECTIONS - PACK R

Grant UK Drawing Number: HPCS-R001ER290

Notes: Some Neutral and Earth connections have been excluded for clarity.

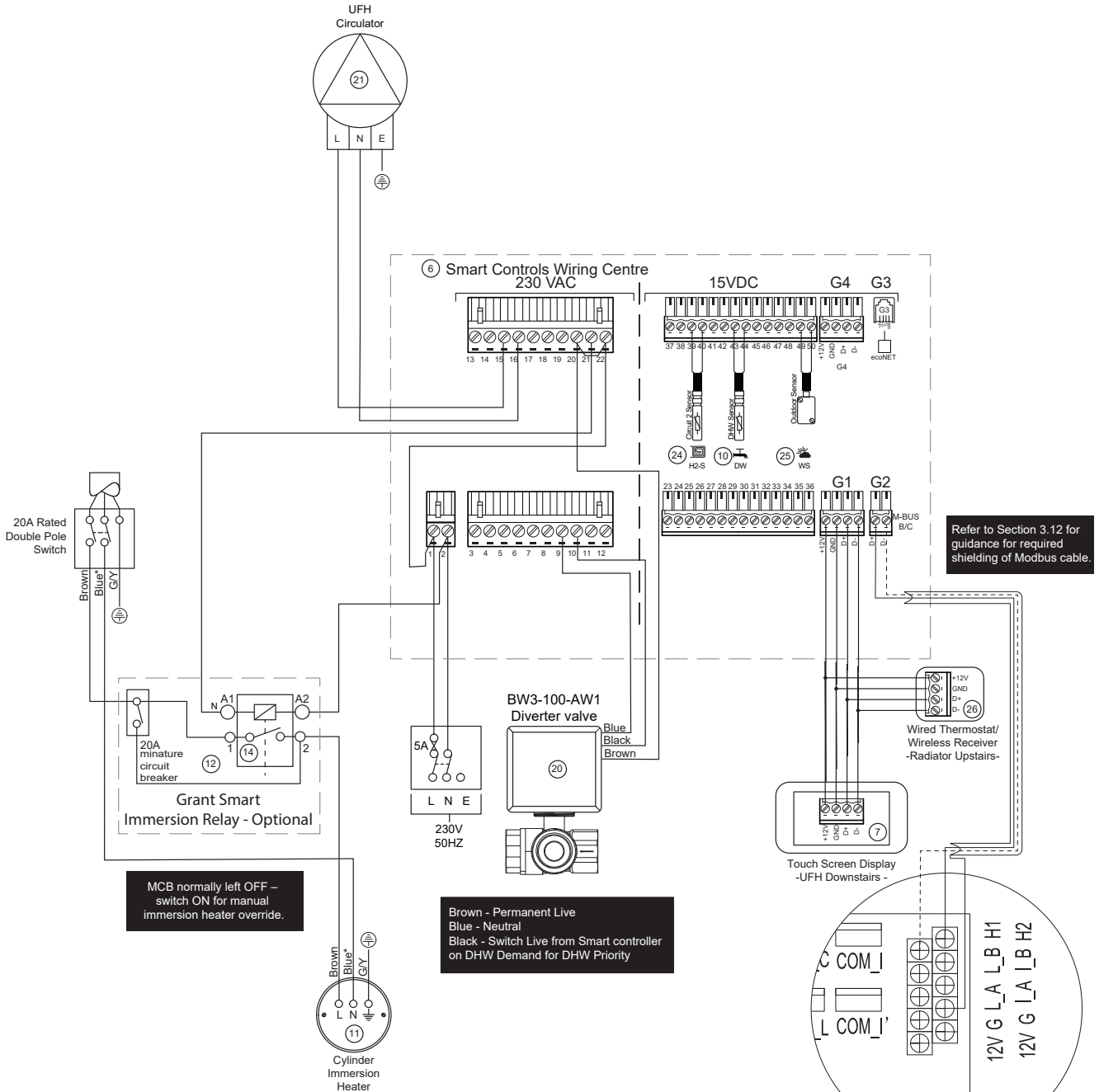

MCB normally left OFF – switch ON for manual immersion heater override.

Brown - Permanent Live
Blue - Neutral
Black - Switch Live from Smart controller on DHW Demand for DHW Priority

Refer to Section 3.12 for guidance for required shielding of Modbus cable.

! NOTE !
Cable shielding must be connected to the ground at the heat pump only when connecting the modbus cable.

! NOTE !
*Please ensure that neutrals are derived from the same supply to prevent spurious MCB/RCD trips.

! NOTE !
This wiring diagram should be read in conjunction with the Grant Aera Smart Controls installation instructions and system schematic HPCS-R001SR290.

① Grant Aera 290 Hydraulic PCB

6 System Configuration with Touchscreen display

6.1 FIRST SWITCH-ON

With installation completed, the Smart controller will need to be configured:

1. Turn on the Smart controller via the wiring centre power switch and allow the software to cycle to the language selection panel. (Refer to Figure 6-1).

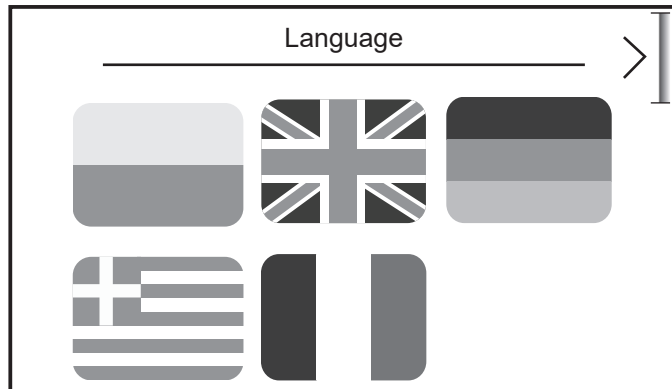

Figure 6-1: Language selection

2. Select required language preference and confirm with >.

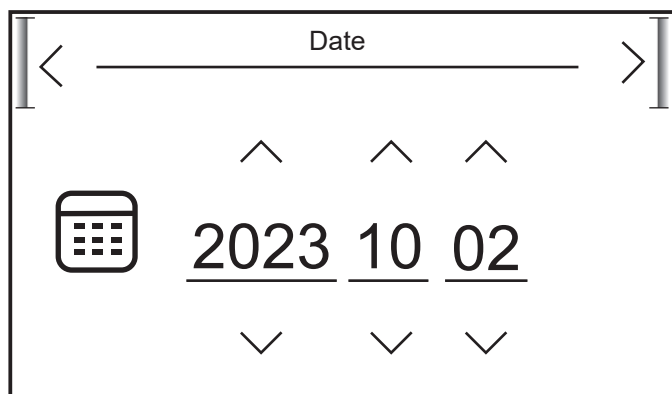

Figure 6-2: Setting date

3. Set the date. Tap the ^ & v to amend the values for year, day and month. Confirm with >. Refer to Figure 6-2.

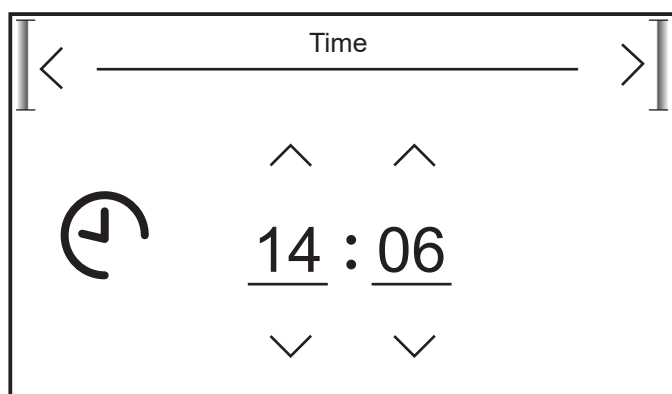

Figure 6-3: Setting time

4. Set the time. Tap the ^ & v to amend the time & confirm with >. Refer to Figure 6-3.
5. The touchscreen will progress to ask if you wish to start a configuration. Tap ✓ to start the configuration creator. Refer to Figure 6-4 and Section 6.2.

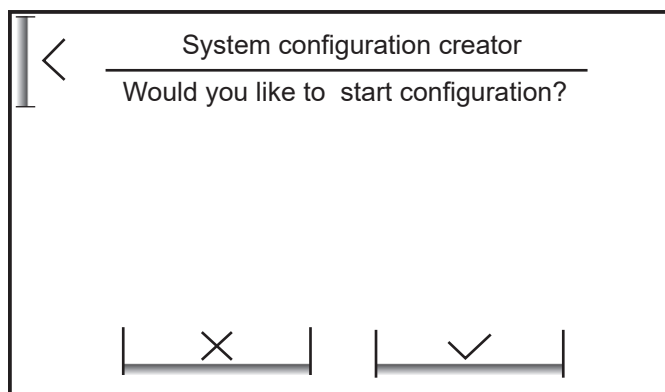

Figure 6-4: Configuration creator

6. If you tap 'X' the controller will take you to the home screen and display "No circuits defined". Refer to Figure 6-5.

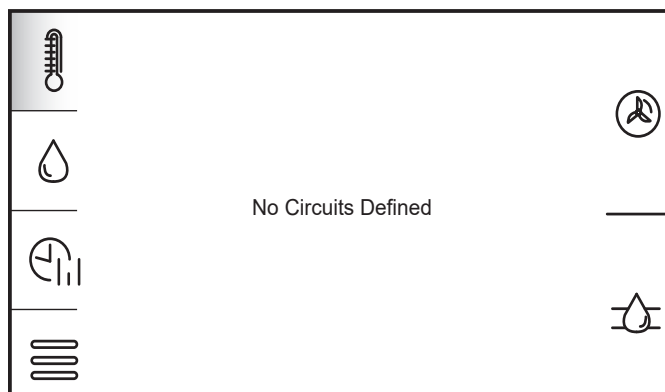

Figure 6-5: No circuits defined

7. To access the system configuration creator you need to access the settings menu / service settings menu. Refer to Section 7 Table 7-1. The service settings password is 0000.

! NOTE !

When configuring the system for the first time, it is recommended to use the system configuration creator.

6.2 SYSTEM CONFIGURATION CREATOR

The Smart Controller integrated system configuration creator will aid with the setup of the space heating and DHW system within the software of the touchscreen display.

The steps in the configuration creator should reflect the system you have designed and electrically connected to the wiring centre.

You must only configure components you have connected (Refer to Section 5.4 Figure 5-3 for wiring centre layout).

! NOTE !

Ensure you pay close attention to the devices you connect to the wiring centre and confirm for correct operation.

Using the system you have planned you can follow the system configuration creator steps to configure it within the Smart controller. (Refer to Figure 6-6 for System configuration map).

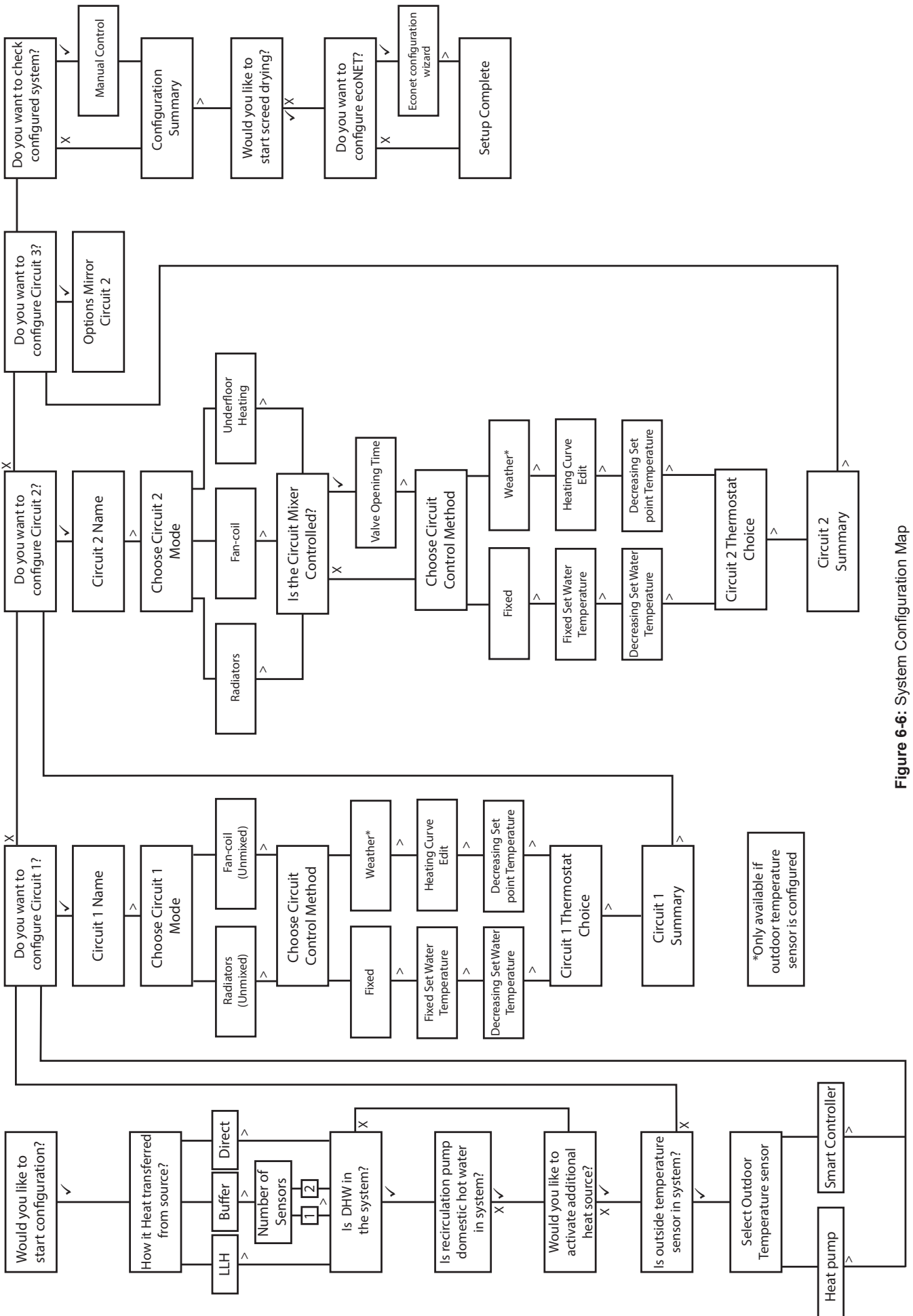

Figure 6-6: System Configuration Map

*Only available if outdoor temperature sensor is configured

! NOTE !

- X - Confirm option is not required and proceed.
- ✓ - Confirm option is required and proceed.
- > - Confirm configurable option and proceed.
- < - Return to previous step in configuration.

- Would you like to start configuration?**
If a system has already been configured you will be prompted to confirm you wish to overwrite the previous setup.
- How is heat transferred from the source?**
Confirm if you are using a volumiser or low loss header that the Smart controller will manage or if heat is transferred directly to the primary circuit.
- Is DHW in the system?**
The Smart controller will manage the DHW cylinder as well as prioritise DHW on a demand.
- Is recirculation pump for DHW in system?**
This would be enabled if you require the Smart controller to manage a secondary circulation pump.
- Would you like to activate additional heat source?**
This would be enabled if you are installing an EvoLink Smart to your system for the controller to manage in conjunction with an external heat source e.g. a gas boiler. Refer to Section 8 for further details.
- Is Outdoor temperature sensor in the system?**
This will enable the weather control features of the Smart controller.
- Source of Outdoor temperature sensor**
Assign an Outdoor temperature sensor. 'Smart Controller' is the outdoor weather sensor supplied with your Smart Controller kit and should be the only option you choose. Refer to Section 3.5.2.

! NOTE !

Ensure to select 'Smart Controller' as your outdoor temperature sensor. This will give the best weather compensation values, if the sensor is placed correctly. Refer to Section 3.5.2.

- Do you want to Configure circuit 1, 2 or 3?**
Configuration of Heating circuits. Circuit 1 is non-adjustable and this is indicated with a note that Circuit 1 cannot have a mixer.
- Circuit Name**
To amend the name of a circuit e.g., "Ground Floor" tap the change name button which will open a qwerty keyboard. To finish tap the enter key.
- Choose circuit mode**
Assign the heating emitter type for the circuit. This could be 'RADIATORS' or 'UNDERFLOOR HEATING'.
- Choose circuit control method**
Assign a control method from either 'FIXED' or 'WEATHER' control. Individual circuits can be assigned differing methods and can be amended later via the Circuit settings within the system settings menu.
- Fixed Set point water temperature (Fixed Control)**
The circuit will operate on a fixed flow temperature. This is the default day flow temperature.
- Decreasing set point water temperature (Fixed Control)**
This is the drop in system flow temperature during scheduled night/unattended periods.
- Heating curve edit (Weather Control)**
Configure the heating curve for the calculative weather control adjustments for set-point temperatures. Refer to 7.13 for further information on setting & editing the heating curve.
- Decreasing set point temperature (Weather Control)**
This is the drop in system flow temperature during scheduled night/unattended periods.

- Will circuit be controlled with a Mixer?**
Confirm if the circuit will be controlled by a motorised mixing valve. (Not applicable to Circuit 1)
- Mixing valve opening time**
Enter the valve opening time to allow the controller to calculate the opening times for correct temperature mixing. (Refer to Appendix C for further information on the mixing valve).
- Circuit thermostat choice**
If required, configure a thermostat to a circuit. A circuit could be uncontrolled, use the touchscreen display or a wired/wireless thermostat. If either a wired or wireless thermostat is chosen, the touchscreen display will begin the pairing wizard to be followed to pair the individual thermostat to this circuit. Refer to Section 7.3.1.4. . If appropriate, at least one circuit can be controlled by the touchscreen display supplied in the Smart Controller kit.

! NOTE !

If more than one wireless thermostat is to be used, you **MUST** ensure you configure the thermostat addresses prior to starting the system configuration creator to avoid conflicts. Refer to Appendix B.4.

- Circuit Summary**
The circuit summary displays the parameters you have defined. The circuit structure displays as a pump but is a 230V switched live output (labelled on the wiring centre as H1-P, H2-P & H3-P. This could be connected to a 2-Port motorised valve as is common in the UK. (Refer to Section 4.12, Figure 4-3).
- Do you want to check configured system?**
Confirming will activate the manual control function (Refer to Section 8 and Figure 8-2) on the touchscreen display. The components that you have configured via the creator will be shown on the screen. There will be both an icon on the operational button area and the terminal block numbers to which they should be wired to on. Refer to Section 4 for the terminal blocks and associated devices that they control. Tapping the icon will switch the internal relay and send a relevant voltage to activate.
- Would you like to start screed drying?**
This would be enabled if you require the Smart controller to begin a pre-configured screed drying process. Refer to Section 7.15 for further details.
- Do you wish to configure ecoNET? (On first install only)**
If you wish to configure ecoNET services tap to confirm and follow the steps in the 'ECONET CONFIGURATION WIZARD' to connect the Wi-Fi hub to the wiring centre and/or pair with the household wireless network. Refer to Section 10 for further details on this process.

! NOTE !

For further assistance with circuit configurations and commissioning the installation refer to Appendix F.

7 Operation and Settings

7.1 TOUCHSCREEN DISPLAY

The display is a capacitive touch screen and parameters are edited by touching the selected symbol or area on the display screen.

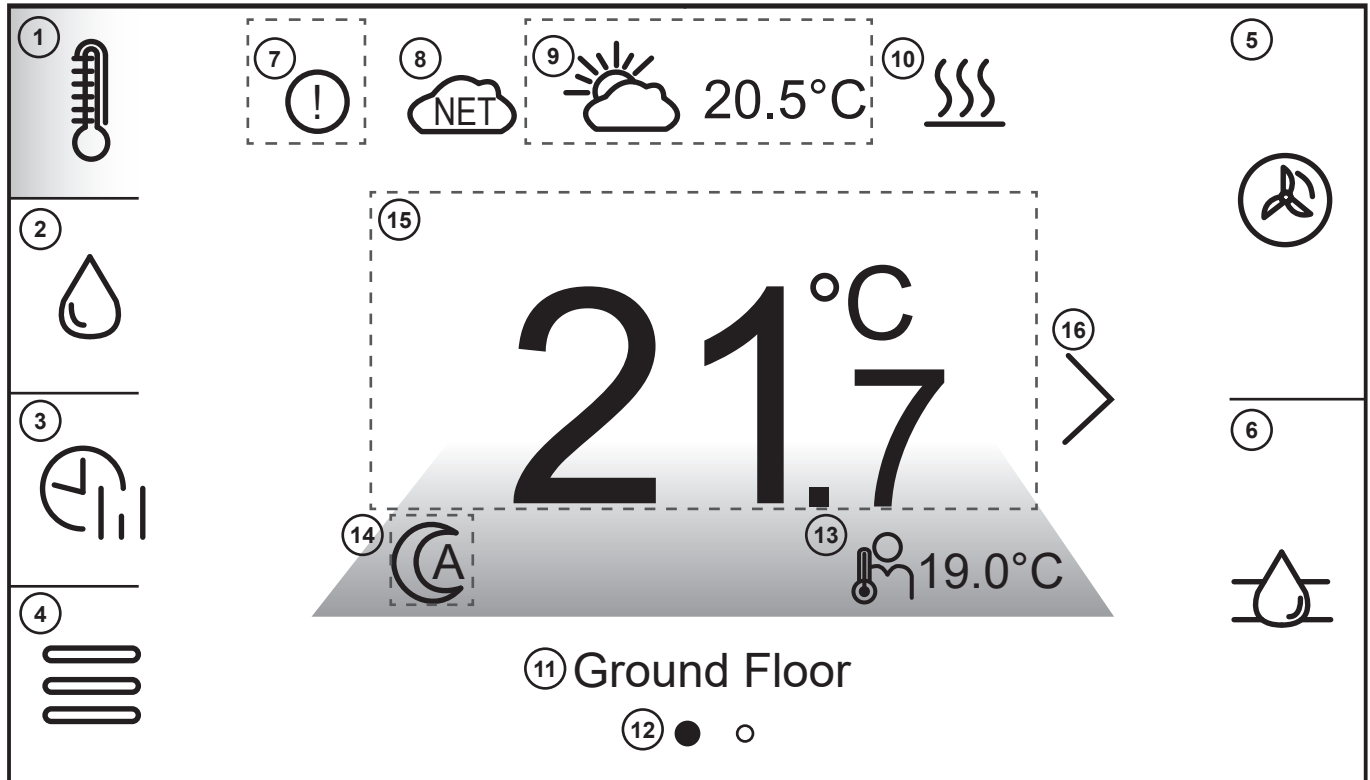

Figure 7-1: Display home screen example

Table 7-1: Touch screen

Number	Symbol	Description
1		Tap to access Heating circuit controls. Refer to Section 7.3.1.1.
2		Tap to access DHW system controls. Refer to Section 7.3.2.1.
3		Tap to access Schedule settings for Heating circuit(s), DHW cylinder and Heat Pump. Refer to Section 7.5.
4		Tap to access to Settings menu. Refer to Section 7.9.
5		Tap to view Heat pump schematic. Refer to Section 7.6.
6		Tap to access active system schematic. Refer to Section 7.7.
7		Indicates there are active alarms on the Smart controller. Tap to view current and previous alarms list.
8		Indicates connection status to ecoNET24 external server. (Green is connected, Red is disconnected)
9		Outdoor temperature value (If outdoor weather sensor support is enabled in the service menu). Tap to view and amend Smart Controller work mode. Refer to Section 7.3.3.
10		Indicates an active heat pump demand.
11	Ground Floor	Circuit title/name
12		Circuit panes available (if more than 1 installed).
13		Circuit user set value.
14		Current circuit work mode. Tap to quick access the circuit work mode screen. Refer to 7.3.1.2 & 7.3.2.2.
15	21.7°C	Current circuit temperature. Tap to access Circuit settings. Refer to 7.3.1.1 & 7.3.2.1.
16		Tap to move between multiple circuits (if installed) - The touchscreen can also be swiped to change circuits.

7.2 SMART CONTROLLER OPERATION

7.2.1 MAIN HEAT SOURCE

The Smart controller manages the operation of the heat pump by activating or deactivating it according to demand for DHW or the space heating circuits.

7.2.2 HEAT CIRCUITS

The Smart controller can manage the operation of one non-adjustable and up to two adjustable heat circuits. Water temperature in circuits can set as a fixed flow temperature or by weather, i.e., water temperature in the circuit is calculated in accordance with a temperature from the external temperature sensor. Despite varying outdoor temperature, a room temperature in heated rooms is kept on a set level.

- Dependent circuits – A thermostat assigned for many circuits. For example, temperature readings on a installed panel affect operation of both radiator and underfloor circuits. Commonly one Thermostat in a central location.
- Independent circuit – Connecting thermostats to measure room temperature independently and affecting assigned circuits. It is the way to obtain independency of the circuits, e.g., in case when one part of the building is used for the whole year and the second part is used periodically, e.g., for rent.

If multiple circuits are being controlled you can navigate between them with a swipe of the screen either to the left or the right.

7.2.3 DOMESTIC HOT WATER

The Smart Controller manages the operation of the Heat Pump and heating of a DHW cylinder up to a user set temperature. DHW operation can be programmed in time intervals with a minimum operation for disinfection mandatory. While the Smart Controller can also control a DHW secondary circulating pump, their use is not recommended to minimise wasted energy and running costs.

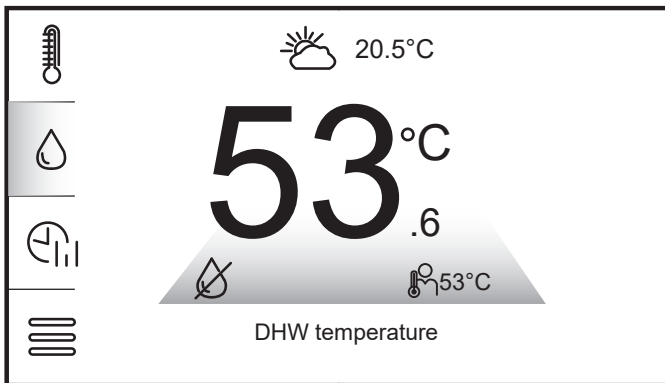

Figure 7-2: DHW temperature display example

! NOTE !

The change of the colour under the current value of the temperature of the circulation and DHW cylinder indicates whether the temperature is below (blue), above (red) or the same (green) as the target temperature. Grey indicates the DHW function is Off.

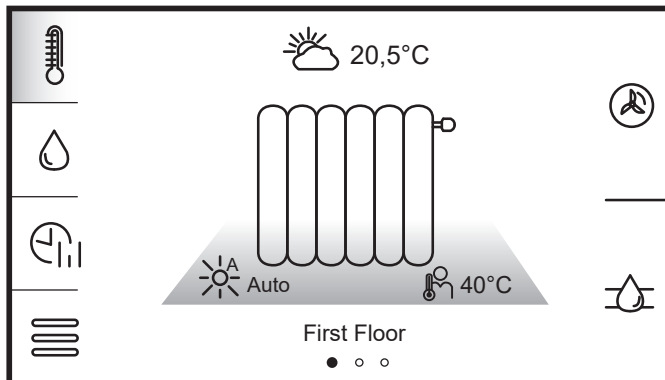

Figure 7-3: Thermostatically uncontrolled circuit display

! NOTE !

The circuit is not controlled by a thermostat if a heat emitter icon is displayed on the circuit temperature display screen.

7.3 CIRCUIT SETTINGS

Tapping the screen on the displayed information of the DHW or a heating circuit you are viewing (if more than 1 heat circuit installed) will open the circuit settings panel. This will display various options that can be edited. Refer to Figure 7-4.

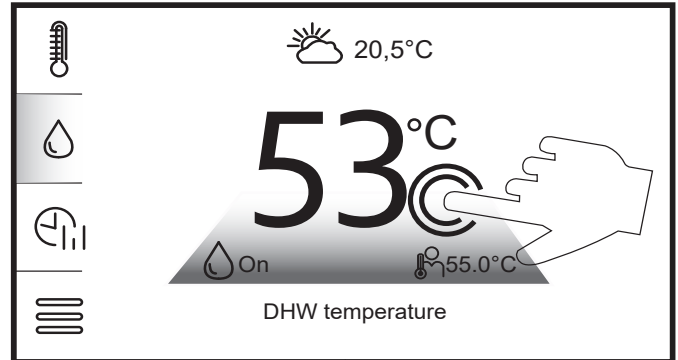

Figure 7-4: Circuit settings access on touch-screen

7.3.1.1 HEAT CIRCUIT SETTINGS

Entering Heat circuit settings will display options the user can edit for the heating circuit. Refer to Figure 7-5.

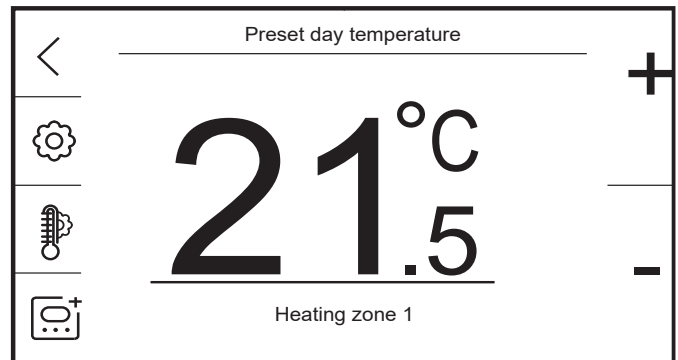

Figure 7-5: Heating circuit settings example





Table 7-2: Heating circuit settings

Button	Function description
<	Navigate back to previous screen.
⚙️	Tap to amend Circuit work mode
🌡️	Tap to view & amend circuit details
📄+	Tap to amend circuit thermostat choice
+	Increase required circuit temperature
-	Decrease required circuit temperature

7.3.1.2 CIRCUIT WORK MODE

The Circuit work mode sets the circuit to operate as per the consumer preference. Tap the work mode icon (Refer to Figure 7-1 Item 14) to view work mode options.

Table 7-3: Heating circuit work modes

Button	Function description
	Auto - Day/Night temperatures based on user schedule
	Off - Circuit will not be heated
	Day Mode - Circuit set to preset day temperature
	Night Mode - Circuit set to preset night temperature
	Boost - Circuit set to day Day mode for 60, 120 or 180 minutes

Tapping 'BOOST' will create a 60 minute space heating period. The icon colour will change and display a counter for the demands remaining time.

The counter can be increased to 120 or 180 minutes with additional taps. If tapped again, the counter will stop and boost will stop.

During boost, the controller will override the circuit schedule to "day mode" to provide heat for the circuit based on the circuit target temperature.

To disable boost, Tap the icon until the icon changes colour to indicate it is off and the counter will disappear.

7.3.1.3 HEATING CIRCUIT DETAILS

The heating circuit details panel will display settings of the circuit which you are viewing/editing. Refer to Figure 7-5.

- 'CIRCUIT NAME' – Name of the circuit, e.g., "Ground Floor".
- 'HYSTERESIS' – The value between when a thermostat switches off and back on. The parameter is only available when a thermostat is assigned to the circuit.
- 'PRESET DAY TEMPERATURE' – The target air temperature for when the circuit is set to/scheduled to be in day mode (occupied). The parameter is available for editing only when a thermostat is assigned to the circuit.
- 'PRESET NIGHT TEMPERATURE' (**Setback temperature**) – The target air temperature for when the circuit is set to/scheduled to be in night mode (overnight/unoccupied). The parameter is available for editing only when a thermostat is assigned to the circuit. The setback temperature should be configured to the ideal comfort level minus the temperature value shown in Table 7.4 below (based on heat emitters configured).

Table 7.4: Recommended setback air temperatures

Heat Emitter	Setback value(°C)
Fan-Coil	3
Radiators	3
Underfloor Heating	1

- Heating curve – Adjust the heating curve and shift. Refer to Section 6.3.

7.3.1.4 HEATING CIRCUIT THERMOSTAT CHOICE





Circuit thermostat choice will allow a circuit thermostat to be configured to the specific circuit.

- None: No Thermostat assigned
- Control Panel: Thermostat within Touchscreen display.
- Wired Thermostat
- Wireless Thermostat
- Contact: External Volt Free Contact (Terminal T1 for Circuit 1 and T2 for Circuit 2 or 3).

7.3.2.1 DHW SETTINGS

As per Figure 7-4 when on the DHW (if installed) you will navigate to the DHW settings.







Table 7-5: DHW settings panel

Button	Function description
	Navigate back to previous screen.
	Tap to amend DHW work mode
	Tap to access DHW additional settings
	Increase required circuit temperature
	Decrease required circuit temperature

7.3.2.2 DHW WORK MODE

DHW work modes give selectable modes as per the consumer preference but also have a optional boost function should the consumer wish (in the event of an expected increase in system demand).

Table 7-6: DHW work modes

Button	Function description
	Navigate back to previous screen.
	Boost - Tap to create a temporary 60 minute DHW demand.
	DHW Immersion Boost - Tap to create 60, 120 or 180 minute Immersion boost
	On - DHW demand on temperature fall by hysteresis (Refer to Section 7.3.2.3)
	Off - Cylinder will not be heated
	Schedule - On/Off based on User schedule

Tapping 'BOOST' will create a 60 minute DHW "ON" period. The icon colour will change (light blue) and display a counter for the demands remaining time. To disable boost, Tap the icon again. The icon will change to grey to indicate it is off and the counter will disappear.

Tapping 'DHW IMMERSION BOOST' will create a 60, 120 or 180 minute DHW "ON" period (depending on number of times the icon is tapped. a 4th time will disable the Immersion boost function, setting it to 0 minutes).

DHW Immersion boost will require both an cylinder immersion element connected to the Smart Controller via a Smart immersion relay (Refer to Appendix D) and the 'DHW HEATER' (Refer to Section 7.4.1 and Section 8) to be configured and when activated, the heat pump will start as per boost but in addition it will ignore 'DHW DELAY' parameters and immediately enable the Immersion heater to assist.

During both boost functions, the controller will provide heat to the cylinder to target temperature. Once reached, DHW priority will cease and the controller will switch to space heating, if scheduled. The work mode icon will also change (as per the Icons shown in Table 7-6) during both boost functions to both show it is in boost and display the countdown showing remaining time.

If the temperature in the cylinder falls by the hysteresis value, the controller will enable DHW priority and begin to heat the cylinder again.

7.3.2.3 DHW ADDITIONAL SETTINGS

DHW additional settings provides a sub menu for the 'DHW CYLINDER HYSTERESIS' parameters & 'DISINFECTION' (If additional heater is configured - Refer to Section 7.4).

'DHW HYSTERESIS' is the amount of temperature drop from the user set temperature in the cylinder before the system will demand more heat in a scheduled ON time period.

If the hysteresis setting is too low this can cause potential cycling of the heat demand in an scheduled ON period. Too high can cause the cylinder to not reach desired temperature and higher energy usage.

7.3.3 CONTROLLER WORK MODE

The Smart Controller work mode of the controller is selected by tapping the currently displayed symbol on the main screen in the place where the value of the outdoor temperature is displayed. (Refer to Table 7.1).

Table 7-7: Controller work mode

Mode	Description
AUTO	Automatically switches on or off the heating-cooling mode (Cooling not available with AERONA ³ or 290 heat pump range), depending on the external temperature.
SUMMER	Adjustable circuit performs the cooling function. (Cooling not available with AERONA ³ or 290 heat pump range)
WINTER	Adjustable circuit performs the heating function.

7.4 LEGIONELLA PROTECTION

The Smart controller has the function to provide protection against legionella by executing a scheduled temperature increase. This is executed on a weekly basis from within the Smart controller settings using the R290 heat pump only. Alternatively, if a cylinder immersion heater is also wired through the Smart Controller, then the R290 & R32 heat pump and the immersion heater will work together to achieve the 60°C for legionella protection.

For protection against legionella the DHW cylinder needs to be periodically raised to a minimum of 60°C to ensure it is sterilised of any present legionella bacteria.

Care must be given to vulnerable people who may be exposed to potentially life-threatening legionella. This group of people include the elderly, pregnant women, young children and those with breathing difficulties. Where legionella disinfection is required more frequently than once a week, this must be provided by other means.

It is important that this decision is based on the welfare of the occupants and not on energy saving measures.

! WARNING !

If the hot water stored in the cylinder has not been used for a prolonged period of time (e.g., a few days) and has not been stored at 60°C, then it is important that the temperature is raised to at least 60°C for a period of one hour before using the hot water.

7.4.1 ENABLING DHW HEATER SUPPORT

'DHW heater' support must be enabled within the system settings menu of the controller for 'disinfection' to be available.

1. Tap the Settings Menu button.
2. Tap 'SERVICE SETTINGS' and input the password: '0000'. Tap 'ENTER' to confirm.
3. Tap 'Installation controller'.
4. Swipe the touchscreen to move down and tap 'HEATERS'.
5. Tap the button next to 'DHW HEATER' to enable heater support.
6. Tap and set 'DHW DELAY' to '15mins' and confirm. (The 15 min delay can be adjusted. The purpose of this 15 minutes is a delay if in central heating mode at the time the legionella protection is due to come on).
7. Tap '<' to navigate back.

7.4.2 CONFIGURING LEGIONELLA SETTINGS

Once DHW heater support has been enabled:

1. Navigate to the DHW circuit screen.
2. Tap the displayed temperature for the cylinder to enter the DHW circuit settings.
3. Tap 'DHW ADDITIONAL SETTINGS' (Refer to Table 7-5).
4. Tap the button next to 'disinfection'. This will expand the display for the individual settings for Legionella protection for configuration.
 - 'Day' - Day to execute Legionella protection.
 - 'Start Hour' - Time to start.
 - 'Preset temp' - Temperature for DHW cylinder to heat to. (Should not exceed 60°C).

The flow temperature from the R290 heat pump will be automatically set at 5°C **higher than the preset temperature**. Once the preset temperature is achieved the legionella disinfection function will be stopped. The heat pump will resume normal operation.

! NOTE !

Legionella protection works independently of the DHW cylinder schedule and will start even if DHW cylinder is scheduled off.

7.4.3 LEGIONELLA DISINFECTION SCHEDULING

Legionella disinfection should be scheduled in a window that is ideally after a DHW demand and in a setback heating demand period e.g. Overnight. This is to avoid the least amount of loss in the heating circuits.

The Legionella protection cannot be run twice in a week should the schedule be changed within the settings.

7.5 TIME SCHEDULES

The Smart Controller allows for programmable time schedules for the Heating Circuit(s), DHW, DHW secondary circulation and the Heat pump itself.

In the situation when the consumer is not at home or at night, the controller can decrease the amount of supplied heat which affects electric consumption.

Time schedules can be set separately for each day of the week or copied across multiple days. If the space is unoccupied Monday to Friday for the same time periods the user could set the hours for Monday and then apply to multiple days.

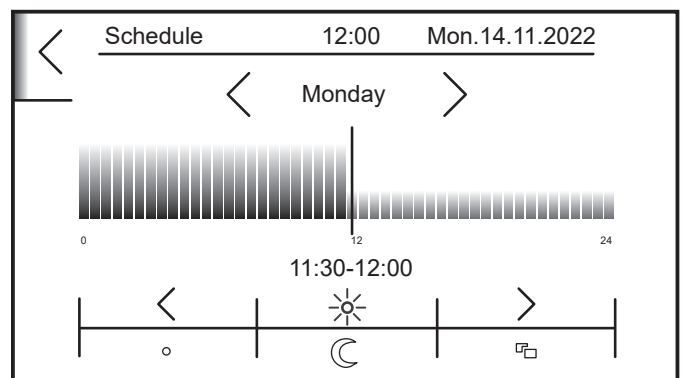

Figure 7-6: Heating time schedule interface

! NOTE !

The ON/OFF time schedule is defined separately for the heat pump and DHW cylinder.

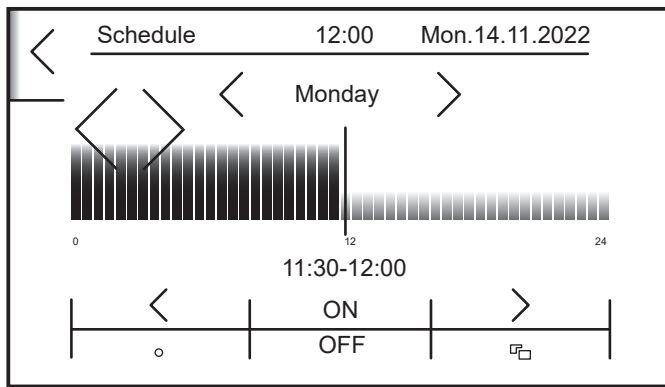

Figure 7-7: DHW/Heat pump time schedule interface

Table 7-8: Time schedule controls

Button	Function description
	Navigation Arrows - Weekday selection and time period selection. Navigate the required day or move selected time period in the specified direction.
	Copy to - Copy the currently set schedule to one or multiple days
	Preset Night mode (Setback Temperature) - Target night temperature for circuits will be applied if a thermostat is assigned to the circuit. If not, the decrease will be set to the value of the Water temperature decrease.
	Preset Day mode - Target day temperature setting for circuits will be applied, if a thermostat is assigned to the circuit.
ON	Option is Configured 'ON'
OFF	Option is Configured 'OFF'

7.5.1 HEATING CIRCUIT SCHEDULE

The schedule for the heating circuit(s) controls the specific time periods at which the target day and night temperatures are applied.

To amend a heating schedule:

1. Tap the time schedule menu (Refer to Figure and Table 7-1). The schedule icon is available regardless of which circuit or device you are currently viewing.
2. Tap the heating circuit you wish to amend from the options.
3. Modify the day if different to current by tapping navigation arrow. Refer to Figure 7-6.
4. Tap the night mode function and use the navigation buttons to move to the first time period you wish to change (if more than one).
5. Tap day mode and use the right navigational button to alter the time periods. Switch between day and night mode for unoccupied portions of the day.
6. After defining the required time schedule it can be applied to multiple days. Tap 'COPY TO' and tap the days required. Refer to Table 7-8. Confirm with ✓.

7.5.2 DHW SCHEDULE

The schedule for the DHW cylinder will turn the cylinder heating function from the heat pump on or off on the selected time periods. If the cylinder temperature falls below hysteresis value in an off time period the heat pump will **not** activate.

To amend the DHW schedule:

1. Tap the time schedule menu (Refer to Figure and Table 7-1). The schedule icon is available regardless of which circuit or device you are currently viewing.
2. Tap 'DHW'.
3. Modify the day if different to current by tapping navigation arrow. Refer to Figure 7-7.

4. Tap the 'OFF' function and use the navigation button to move to the first time period you wish to change. (if more than one).
5. Tap 'ON' and use the right navigational button to alter the time periods. Switch between 'ON' and 'OFF' to create multiple intervals based on end-user requirements
6. After defining the required time schedule it can be applied to multiple days. Tap 'COPY TO' and tap the days required. Confirm with ✓. Refer to Table 7-8.

We recommend to schedule up to 4 x 1 hour on periods in a day with a minimum gap of 1 hour between each.

7.5.3 HEAT PUMP SCHEDULE

The schedule for the heat pump will disable the heat pump from activating in the off periods

To amend the Heat pump schedule:

1. Tap the time schedule menu (Refer to Figure and Table 7-1). The schedule icon is available regardless of which circuit or device you are currently viewing.
2. Tap 'HEAT SOURCE'.
3. Modify the day if different to current by tapping navigation arrow. Refer to Figure 7-7.
4. Tap the 'OFF' function and use the navigation button to move to the first time period you wish to change. (if more than one).
5. Tap 'ON' and use the right navigational button to alter the time periods. Switch between 'ON' and 'OFF' to create multiple intervals based on end-user requirements
6. After defining the required time schedule it can be applied to multiple days. Tap 'COPY TO' and tap the days required. Confirm with ✓. Refer to Table 7-8.

We recommend you leave the Heat pump enabled 'ON' at all times. This does not mean the heat pump will be running continually.

! NOTE !

The heat pump schedule will override all other schedules and could cause unwanted heat loss within the space heating or DHW circuits.

7.5.4 DHW SECONDARY CIRCULATION SCHEDULE

The schedule for DHW secondary circulation controls the specific time period(s) at which DHW secondary circulation will be enabled. In addition to scheduling your ON/OFF time periods, you will need to set your secondary circulation cycling parameters. Refer to Section 7.12 and Section 8.

To amend a heating schedule:

1. Tap the time schedule menu (Refer to Figure and Table 7-1). The schedule icon is available regardless of which circuit or device you are currently viewing.
2. Tap 'SECONDARY CIRCULATION'.
3. Modify the day if different to current by tapping navigation arrow. Refer to Figure 7-7.
4. Tap the 'OFF' function and use the navigation button to move to the first time period you wish to change. (if more than one).
5. Tap 'ON' and use the right navigational button to alter the time periods. Switch between 'ON' and 'OFF' to create multiple intervals based on end-user requirements
6. After defining the required time schedule it can be applied to multiple days. Tap 'COPY TO' and tap the days required. Confirm with ✓. Refer to Table 7-8.

! NOTE !

Secondary circulation should be carefully planned to ensure both a satisfactory supply of hot water reaches the specific outlets and there is not too much heat being taken from the DHW Cylinder unnecessarily.

7.5.5 SILENT MODE SCHEDULE (AERONA 290 ONLY)

The schedule for silent mode will enable the feature based on the level configured in the menu screen. Refer to Section 7.6 for more information on accessing silent mode parameters.

To amend the Heat pump schedule:

1. Tap the time schedule menu (Refer to Figure and Table 7-1). The schedule icon is available regardless of which circuit or device you are currently viewing.
2. Tap 'SILENT MODE'.
3. Modify the day if different to current by tapping navigation arrow. Refer to Figure 7-7.
4. Tap the 'OFF' function and use the navigation button to move to the first time period you wish to change. (if more than one).
5. Tap 'ON' and use the right navigational button to alter the time periods. Switch between 'ON and 'OFF' to create multiple intervals based on end-user requirements
6. After defining the required time schedule it can be applied to multiple days. Tap 'COPY TO' and tap the days required. Confirm with ✓. Refer to Table 7-8.

The use of Silent mode is at the discretion of the installer/homeowner and as such Grant UK accept no liability for faults or issues with the unit if used in this manner.

7.6 HEAT PUMP SCHEMATIC

The heat pump schematic gives a visual preview of the basic operating functions of the heat pump such as working status, Flow/return temperatures as well as being able to configure the operating mode of the heat pump in relation to the system installed.

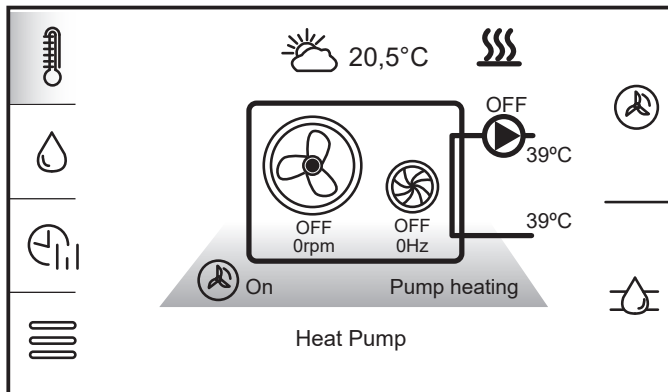

Figure 7-8: Heat pump scheme interface

The heat pump operating modes are accessed by tapping the heat pump scheme icon. Refer to Table 7-9 and Figure 7-8.

Table 7-9: Heat Pump Status

	ON	The heat pump is turned on.
	OFF	The heat pump is turned off regardless of the conditions in the system.
	SCHEDULE	The heat pump is turned on and off according to the set time schedule for the heat pump.

Tapping on the heat pump schematic will open a sub-menu screen that contains some heat pump specific options.

7.6.1 OVERRIDE MODE

'Override Mode' is available when 'additional heat source' (AHS) has been enabled and will cause the AHS to become the primary supply for space heating and DHW demands through the Aerona Smart Controller. Refer to Appendix J

Tap the toggle icon to enable/disable.

7.6.2 SILENT MODE (AERONA 290 ONLY)

Silent mode for the Aerona 290 limits the speed of both the compressor and fan(s) during any space heating or DHW demand to reduce the noise of the heat pump.

The 2 options available for silent mode are:

- Silent mode: This enables silent mode based on the level configured and the schedule set (Refer to Section 7.5.5).
- Silent mode level: This configures the level of silent mode required. Level 2 is a greater limit than level 1.

! CAUTION !

Silent mode limits the speed of the compressor and fan(s) and will in turn affect the overall output capacity of the heat pump.

7.7 SYSTEM SCHEMATIC

The system scheme display shows the scheme of the installed and configured system. Icons will change from white to green to indicate they are active such as a motorised valve or the Heat pump. Refer to Figure 7-9 for system schematic example.

Installed diverter valves will indicate via the symbol which direction it is causing the heat to travel. Mixer valves will display a % figure to show their open status.

The system schematic also displays water temperatures from installed sensors (DHW Cylinder, Volumiser Low-Loss Header, Water temperature sensors on adjustable circuits).

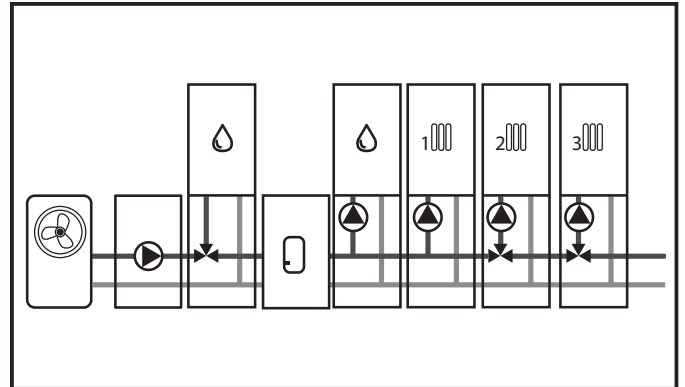

Figure 7-9: System schematic display

! NOTE !

The view of the system schematic depends on the enabled support for the individual circuits, DHW cylinder or volumiser installed.

7.8 CIRCUIT CONTROL

The 3 available heating circuits in the Smart controller are connected and controlled via the following terminals within the wiring centre (Refer to section 5).

Table 7-10: Circuit terminals

Heating circuit	230V Pump/Valve Terminals
1	13(L) & 14(N)
2	15(L) & 16(N)
3	17(L) & 18(N)

Each heating circuit can either have a circulation pump or motorised valve connected to it.

In a conventional system the thermostat (or sensor) will stop the pump or close valve when the actual circuit air temp reaches the target circuit air temp.

7.8.1 THERMOSTATIC PUMP BLOCKADE

Thermostatic pump blockade is a hydraulic control feature within the heating circuit setting that enables the Grant Aerona Smart controller to either switch a circuit pump/valve **OFF** (Thermostatic Pump blockade **ON**) or keep the circuit active (Thermostatic Pump blockade **OFF**) based on the status of an installed thermostat monitoring the circuit.

This function can be used to control both mixing and non-mixing circuits. Refer to Section 7.8.1.1 for further details on how to activate and use this function.

Refer to Figure 7-10 and 7-14 for hydraulic control application for Circuit 1 (non-Mixing) and Circuits 2 and 3 (Mixing) utilising 'Thermostatic pump blockade'.

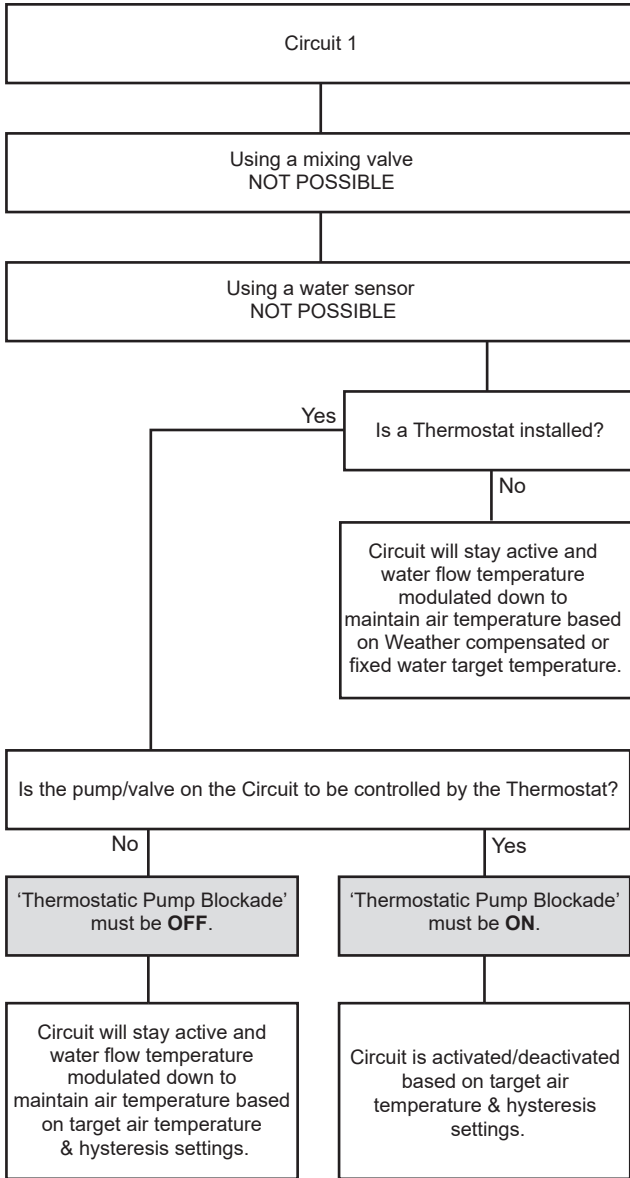

Figure 7-10: Circuit 1 Hydraulic controls

If a thermostat has been installed on any heating circuit, you have the following choices in how to control that circuit:

- With pump blockade 'ON'** - Each heating circuit thermostat will control the circulating pump or motorised valve (whichever is installed) for that circuit based on the air temperature the sensor/thermostat is monitoring.
- With pump blockade 'OFF'** - The heating circuit will continue to have circulating pump or motorised valve enabled (whichever is installed) but the smart controller will drive down the flow temperature to the minimum value to maintain the target air temperature within the circuit i.e the circuit remains active. This option would be best suited for open loop room optimisation.

7.8.1.1 ENABLE THERMOSTATIC PUMP BLOCKADE

To enable Thermostatic pump blockade for a circuit:

- Tap the Settings menu and then 'SERVICE SETTINGS'. Enter the password: 0000 on the keypad provided and tap 'Enter'. Refer to Table 7-1 and Section 8 for full Service settings parameters listing.

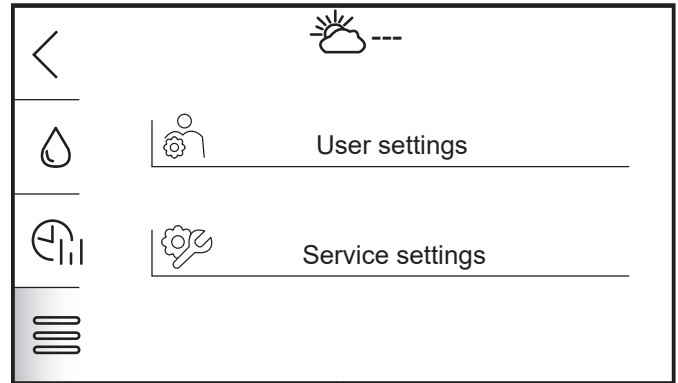

Figure 7-11: Service Settings menu

- Tap 'Installation controller'
- Swiping the Touchscreen display scroll down to the desired circuit and select by tapping. (Refer to Figure 7-12).

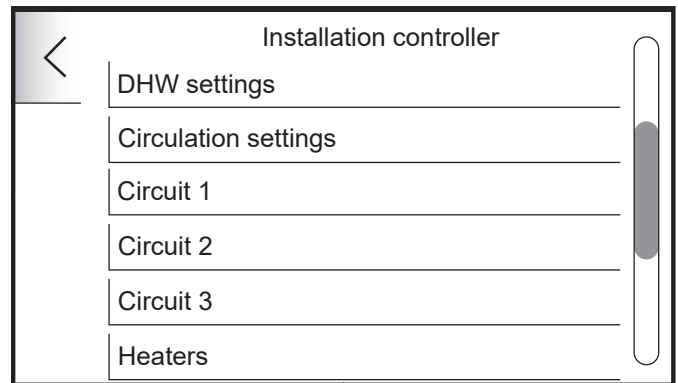

Figure 7-12: Installation controller menu

- Swiping the touchscreen display scroll down to 'Thermostatic pump blockade'. Tap the icon to switch on. (Refer to Figure 7-13)

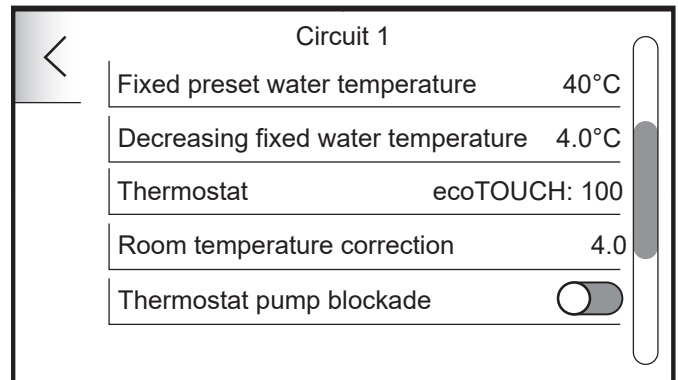

Figure 7-13: Edit Circuit 1 settings

- Tap the < button to navigate backwards to the home screen.

7.8.2 PUMP ONLY/MIXING

Circuits 2 and 3 can function as either a mixing or non-mixing space heating circuit. Using the System configuration creator (Refer to Section 6), you are prompted to confirm if the circuit is controlled with or without a mixer, which in turn will create the circuit and apply the required settings.

If a mixer is not specified, 'PUMP ONLY' will be automatically set to **ON** within the circuit control settings. This will also display the 'CIRCUIT STOP FROM PRESET TEMP' control within the circuit settings. Refer to Figure 7-15.

If a mixer is specified, 'PUMP ONLY' will be automatically set to **OFF** within the Circuit control settings. The menu will not display 'CIRCUIT STOP FROM PRESET TEMP', but will have the option for the mixing valve including the 'VALVE OPENING TIME' which will be used by the Smart Controller to open and close the mixing valve for the desired circuit.

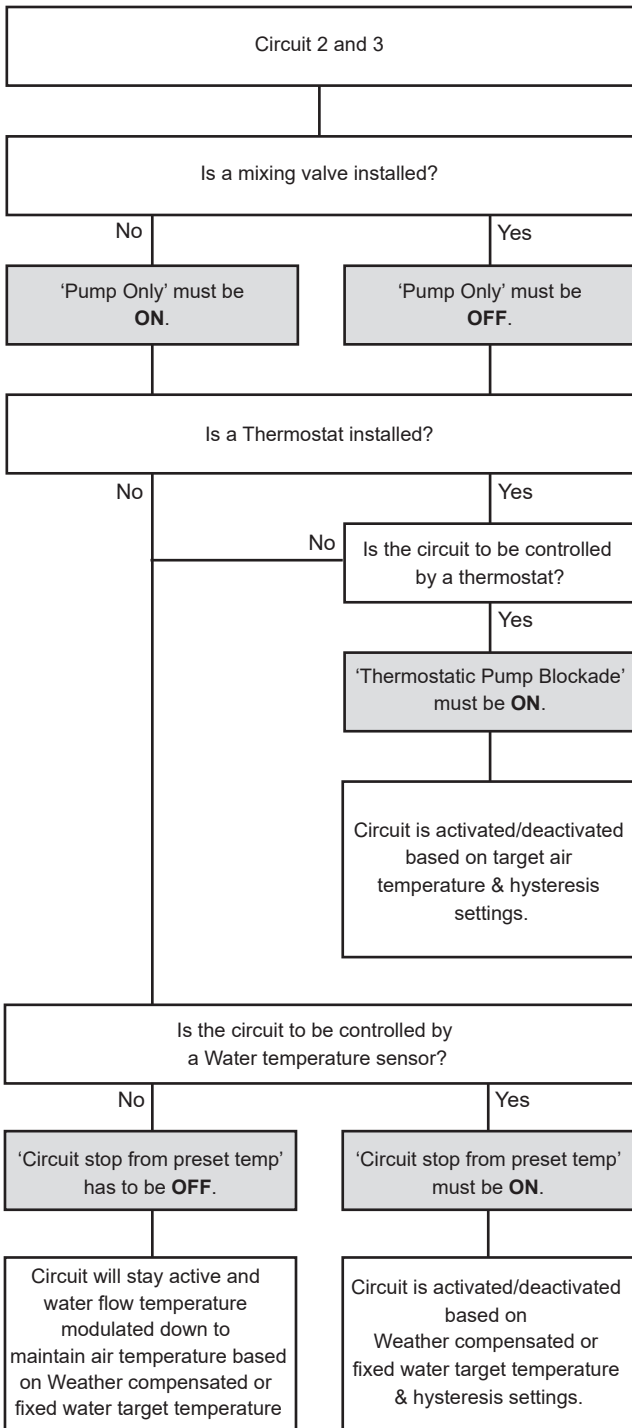

Figure 7-14: Circuit 2&3 Hydraulic controls

7.8.2.1 CIRCUIT STOP FROM PRESET TEMP

'CIRCUIT STOP FROM PRESET TEMP' is a hydraulic control feature within a mixing heating circuit setting that enables the Grant Aerona Smart controller to either switch a circuit pump/valve **OFF** (Circuit stop on Preset temp **ON**) or keep the circuit active (Circuit stop on Preset temp **OFF**) based on the status of an installed water temperature sensor on the flow in the circuit.

This function can only be used on Circuits 2 and 3 when used as a non-mixing circuit.

Refer to Figure 7-14 for hydraulic control application for Circuit Circuits 2 and 3 (Mixing) utilising 'PUMP ONLY', 'CIRCUIT STOP FROM PRESET TEMP' and 'THERMOSTATIC PUMP BLOCKADE'.

1. **With Circuit stop from preset Temp 'ON'** - The water temperature sensor will monitor the water temperature of the flow into the circuit from the heat pump and directly control the circulating pump or motorised valve closed when the target water temperature is achieved.
2. **With Circuit stop from preset Temp 'OFF'** - The heating circuit will continue to have circulating pump or motorised valve enabled (whichever is installed) but the smart controller will drive down the flow temperature to the minimum value to maintain the target water temperature within the circuit i.e the circuit remains active. This option would be best suited for open loop room optimization.

! NOTE !

If a mixer is installed on circuit 2 or 3, 'Circuit stop from preset temp' will not be available.

7.8.2.2 ENABLE CIRCUIT STOP FROM PRESET TEMP

To enable Circuit stop from preset temp for a circuit:

1. Tap the Settings menu and then 'SERVICE SETTINGS'. Enter the password: 0000 on the keypad provided and tap 'ENTER'. Refer to Table 7-1 and Section 8 for full Service settings parameters listing.
2. Tap 'INSTALLATION CONTROLLER'
3. Swiping the Touchscreen display scroll down to the desired circuit and select by tapping. (Refer to Figure 7-12).
4. Swiping the touchscreen display scroll down to 'CIRCUIT STOP FROM PRESET TEMP'. Tap the icon to switch on. (Refer to Figure 7-15).

! NOTE !

'PUMP ONLY' must be enabled. Refer to Figure 7-15.

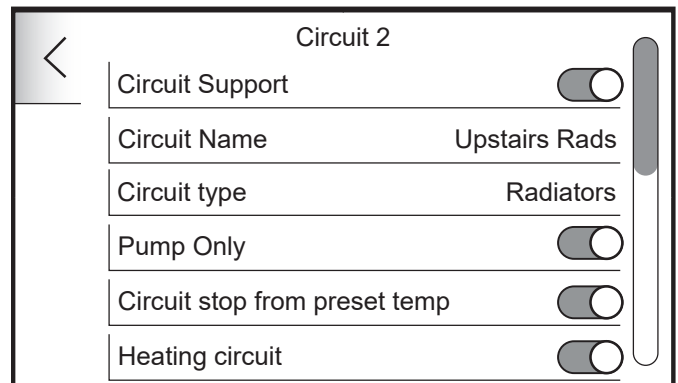

Figure 7-15: Edit Circuit 2 settings

5. Tap the '<' button to navigate backwards to the home screen. Irrespective of whether pipe sensors are used or not, the space heating performance can be adjusted based on user comfort levels using either the Smart controller or via ecoNET24. (Refer to Section 7.13 for Heating curve adjustment guidance)

7.9 USER SETTINGS MENU

User settings can be accessed via the settings menu from the touchscreen display. (Refer to Figure and Table 7-1 and Figure 7-1).

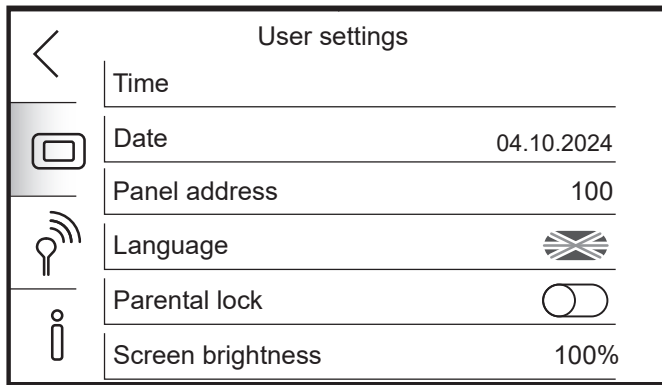

Figure 7-16: User settings menu

- Time - Time will synchronise with paired thermostats.
- Date
- Panel Address
- Language - Menu language selection.
- Parental Lock - The lock will activate after 5 minutes of inactivity. Unlocking the screen is possible after pressing down the screen for 5 seconds.
- Screen Brightness
- Screen saver - Choose screen saver display: None, Empty, Time, Time and Temps.
- Time to screen saver on
- Brightness in screen saver.
- Alarm sound - Enable/Disable Alarm sounds.
- Key sound - Enable/Disable Key sounds.
- Panel temperature correction.

! NOTE !

The temperature in the room should be measured with an additional temperature sensor and the difference between this measurement and the temperature value displayed by the Touchscreen display should be entered into the value of this parameter.

Tapping the radio icon symbol (Refer to Figure 7-16):

- Econet configuration wizard - Start the configuration wizard for connecting to econet with the Wi-Fi Hub.
- Econet status - Displays the connection status of Wi-Fi hub and Econet web services. The presented QR code will generate your UID on the device used to scan. This can then be copied for use.
- Wi-Fi settings - Allows the user to manually configure of connection with Wi-Fi Hub. Connection of Wi-Fi and its configuration is described in this manual. Parameters that should be set by the user: SSID, Security type and network access password.

Refer to Section 10 for Wi-Fi hub connection.

Tapping the **i** symbol (Refer to Figure 7-16) will display a panel of sub menus to access system information based on current installation.

- Diagnostic info - Displays information of the current installed system including Heat pump and circuit information, electric counters, flow rates and average COP/EER.
- Alarm list - view list of current and historical alarms.
- Energy Monitor (if enabled) - will display system counter information for the User. IF SD card is inserted the user will also be able to view historical data. Refer to Section 8 - Data registration.
- Firmware Version - View current software versions along with UID and serial number for the installed controller.
- Firmware update - Tap to begin the software updater (if an appropriate SD card is installed).

7.10 STORED SYSTEM SETTINGS

The Smart controller can store and recall a default system setting scheme within its memory.

Once the system has been installed and commissioned the applied settings (including demand schedules and Legionella protection) can be stored within the Smart controller. This can be recalled if a setting is perhaps inadvertently changed causing issues with the system.

7.10.1 SAVE A SYSTEM DEFAULT

To store the currently set system as a default you will need to:

1. Tap the Settings menu and tap 'SERVICE SETTINGS'. Input the relevant password on the keypad and tap enter. (Password: 0000 - Refer to Section 8).
2. Tap 'INSTALLATION CONTROLLER'.
3. Swipe the screen to scroll down to the bottom and tap 'DEFAULT SETTINGS'.
4. Tap 'SAVE CURRENT SETTINGS AS DEFAULT'.

7.10.2 RESTORE SYSTEM DEFAULT

To restore the currently saved default to the Smart Controller:

1. Tap the Settings menu and tap 'SERVICE SETTINGS'. Input the relevant password on the keypad and tap enter. (Password: 0000 - Refer to Section 8).
2. Tap 'INSTALLATION CONTROLLER'.
3. Swipe the screen to scroll down to the bottom and tap 'DEFAULT SETTINGS'.
4. Tap 'RESTORE DEFAULT'.

! NOTE !

Any paired thermostats will need to be re-paired after a system default has been restored. The memory will clear if unpowered for an extended period of time.

7.11 SECONDARY CIRCULATION

Secondary circulation functions allow for the cyclic pumping of hot water from the DHW cylinder to outlets that may be some distance from the cylinder.

The warmer water will be closer to the outlet, thus wasting less water as it will be warmer sooner whilst hot water from the cylinder is pulled behind it.

7.11.1 SECONDARY CIRCULATION PUMP

The Terminals allocated for secondary circulation are 11 & 12 (Refer to Section 4). As stated this terminal set is a Switched relay and not a Switched Live.

Any connected pump must be appropriately fused external of the wiring centre (maximum 3.15A) with your Neutral returning to any of the neutral sockets of the wiring centre.

If the pump intended needs a different power supply, you will need to link a live as above but connect the outgoing to A1/A2 of the relay to switch your alternate supply to power on the pump.

7.11.2 SECONDARY CIRCULATION SCHEDULING

The smart controller can schedule the periods at which secondary circulation is enabled (Refer to Section 7.5.4). When Secondary circulation is in an ON period, the operation and temperature settings specified will be applied until the OFF period begins.

7.11.3 SECONDARY CIRCULATION SETTINGS

With secondary circulation enabled and in a scheduled ON period, the secondary circulation settings will be applied (Refer to Section 8).

These settings follow a cyclic pattern based of:

- Circulation Operation Time - Time in seconds for the Circulation pump to operate.
- Circulation Pause time - Time in minutes between operation.
- Start from temperature - Temperature threshold for operation time. If the cylinder falls below this temperature, the operation will not start.

7.12 SYSTEM CONTROLS

7.12.1 OFF CIRCUITS DURING CHARGING

'OFF CIRCUITS DURING CHARGING' offers the ability to control all space heating circuits during a DHW demand when a system managed volumiser or low loss header is installed.

If configured ON, 'OFF CIRCUITS DURING CHARGING' will disable all heating circuits outputs from the wiring centre, when a DHW demand is active.

If configured OFF, 'OFF CIRCUITS DURING CHARGING' will not disable all heating circuits outputs from the wiring centre, when a DHW demand is active.

Refer to Section 8 'DHW SETTINGS' to enable or disable.

7.12.2 CIRCUIT TEMP. FROM THE HEAT PUMP RETURN

Should mixing valves not be installed on the adjustable circuits, it is possible to remove the water temperature sensor functionality. This will allow the smart controller to operate Circuits 2 and/or 3 to work without the need for a water temperature sensor to be installed and connected.

When set to 'ON' the circuit temperature reading is replaced by the return temperature value of the heat pump. Refer to Section 8 - main heat source.

If a Low Loss header is installed and configured, this function will not be available and circuit water temperature sensors will need to be installed on any active circuits.

7.13 WEATHER COMPENSATION

7.13.1 HEATING CURVE

Weather compensation can be enabled if an Outdoor Weather sensor is connected. The Outdoor Weather sensor should be enabled and select Regulation method as 'WEATHER'.

The circuit water target temperature is calculated based on the ambient temperature outside the building. The colder it is outside, the higher the water temperature in the circuit will be.

The heating curve is configured per circuit either during system configuration or via the service menu of the controller.

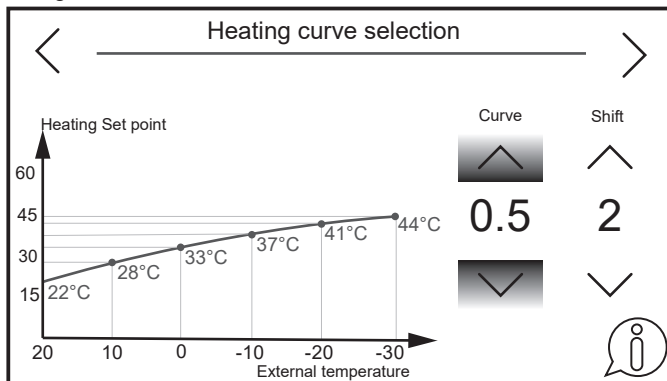

Figure 7-17: Heating curve adjustment

The heating curve selection will provide the line graph representing required target water temperature against outdoor air temperature (Refer to Figure 7-17).

- Tap \wedge or \vee of 'CURVE' to align the curve to set a 45°C at -3°C 'External temperature' as a starting point. Refer to Table 7-11 for recommended heating curve settings.
- To further adjust should the temperature points not be satisfactory, Tap \wedge or \vee of 'Shift' to move the set curve up or down.

Table 7-11: Recommended Heating Curve

Heat Emitter	Initial Curve Setting
Fan-Coil	1.2 - 1.6
Radiators	1.2 - 1.6
Underfloor	0.2 - 0.6

Refer to Section 7.13.2 for advice on how to further alter the heating curve.

The Smart Controller can increase or decrease the Heat pump target flow temperature, calculated in accordance with the heating curve, if it exceeds the temperature range for the given circuit set in controller service menu.

7.13.2 HEATING CURVE ADJUSTMENT

The heating curve is adjustable and should be reviewed to ensure both comfort and economy.

The heating curve can be set as part of the initial system configuration when configuring 'WEATHER' control or be edited after the system configuration has been completed. Refer to Section 7.3.1.3 to access the heating curve setting adjustment, Figure 7-17 and Online resources for a QR code link to a 'how-to' video on adjusting the circuit heating curve.

Guidelines for adjusting a heating curve

- If the outdoor temperature drops, and the room temperature increases, the selected heating curve value is too high.
- If the outdoor temperature drops, and the room temperature drops as well, the selected heating curve value is too low.
- If during frosty weather the room temperature is comfortable, but when it gets warmer the room is too cold, it is recommended to increase the Heating curve shift and to select a lower heating curve.
- If during frosty weather the room temperature is too cold, and when it gets warmer the room is too hot, it is recommended to decrease the Heating curve shift and to select a higher heating curve.

Poorly insulated buildings or the use of traditional steel radiators require setting higher heating curves. Well insulated buildings and/or low temperature heat emitters e.g. Underfloor heating, heating curves will have a lower value.

7.14 CIRCUIT OPERATION

7.14.1 UNCOMPENSATED CIRCUITS

Circuits can be configured with a preset water temperature for the circuit, which can either be managed with or without a thermostat.

Without a thermostat

- The circuit will be supplied with a fixed water flow temperature for the scheduled day/occupied time period of the circuit. The temperature is determined by 'FIXED PRESET WATER TEMPERATURE', set during system setup or in the Circuit settings.
- During a scheduled night/unoccupied time period, the fixed water flow temperature will be reduced by the configured value 'DECREASING FIXED WATER TEMPERATURE' set during system setup or in the circuit settings.
- If a water temperature sensor is installed on circuits 2 or 3, you have the ability to stop the circuit demand by enabling 'CIRCUIT STOP FROM PRESET TEMP'. Once the water temperature reaches the desired temperature the circuit demand will stop.

With a thermostat

- Target air temperature is set on the assigned thermostat and the 'FIXED PRESET WATER TEMPERATURE' is supplied to the heating circuit and will operate in a similar fashion to without a thermostat
- If 'THERMOSTATIC PUMP BLOCKADE' is enabled, the circuit demand will be stopped once the target air temperature set on the thermostat is reached.
- If 'THERMOSTATIC PUMP BLOCKADE' is not enabled, once the target air temperature is achieved the smart controller will decrease the flow temperature target by the 'DECREASING FIXED WATER TEMPERATURE' value, which is set correctly will maintain the target air temperature. Refer to 7.3.1.3 for recommended setback values based on heat emitters for the circuit.

7.14.2 WEATHER COMPENSATED CIRCUITS

The Outdoor weather sensor must be installed and configured to be able to use weather compensation control. Refer to Table 7-11 for recommended weather compensation curve settings based on heat emitters.

'SHIFT' is used to further target a room temperature value. The target preset room temperature should be achieved with a base value of 20°C plus the heating curve shift value.

Without a thermostat

- Target flow temperature is calculated based on current ambient air temperature, from the heating curve & shift set for a scheduled day/occupied period.
- If a water temperature sensor is installed, once the target flow temperature is achieved the smart controller will decrease the flow temperature target by the 'DECREASE WATER TEMPERATURE' value, which if set correctly will maintain the target design temperature for the circuit.
- During a scheduled night/unoccupied time period, the water flow temperature will be reduced by the configured value 'DECREASE WATER TEMPERATURE' set during system setup or in the circuit settings.
- If a water temperature sensor is installed on circuits 2 or 3, you have the ability to stop the circuit demand by enabling 'CIRCUIT STOP FROM PRESET TEMP'. Once the water temperature reaches the desired temperature the circuit demand will stop.

With a thermostat

- When a target air temperature is set on the assigned thermostat, the smart controller calculates flow based on ambient temperature, heating curve and current circuit air temperature.
- If 'THERMOSTATIC PUMP BLOCKADE' is enabled, the circuit demand will be stopped once the target air temperature set on the thermostat is reached.
- If 'THERMOSTATIC PUMP BLOCKADE' is not enabled, once the target air temperature is achieved the smart controller will use decrease the flow temperature target by the 'DECREASE WATER TEMPERATURE' value, which is set correctly will maintain the target air temperature. Refer to 7.3.1.3 for recommended setback values based on heat emitters for the circuit.

7.15 SCREED DRYING

A pre-programmed 30 day screed drying function is available within the Grant Aeron Smart Controller. The flow temperature from the heat pump is slowly increased to aid the drying of laid screed whilst avoiding cracks and shrinkage.

When screed drying has been enabled, the controller will open all configured heating circuits and follow the pre-programmed schedule. Refer to Table 7-12 for the screed drying schedule and temperatures applied.

Table 7-12: Screed drying

Days	Flow temperature (°C)
1 - 7	25
8 - 14	30
15 - 21	35
22 - 30	30

! NOTE !

During screed drying, Both circuit schedules and temperatures can not be adjusted.

The circuit work mode icon will change to indicate the screed drying function is active. Refer to Figure 7-18.

7.15.1 ACTIVATING SCREED DRYING

Screed drying can be enabled either by:

- Enabling in the System configuration process Refer to Figure 6-1 for System configuration wizard map. When prompted, Tap the Tick will enable the Screed drying function.
- or
- Enabling via the System settings menu.
 1. Tap the Settings menu and tap 'SERVICE SETTINGS'. Input the relevant password on the keypad and tap enter. (Password: 0000 - Refer to Section 8).
 2. Tap 'INSTALLATION CONTROLLER'.
 3. Swipe the screen to scroll down and tap 'SCREED DRYING'.
 4. Tap 'ON'.

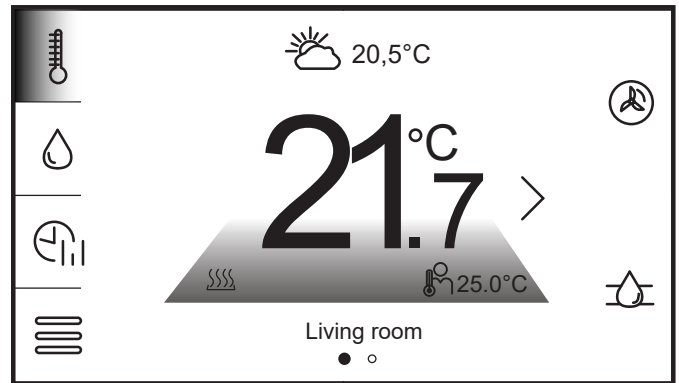

Figure 7-18: Screed drying active

7.15.2 DISABLE SCREED DRYING

To disable screed drying :

1. Tap the Settings menu and tap 'SERVICE SETTINGS'. Input the relevant password on the keypad and tap enter. (Password: 0000 - Refer to Section 8).
2. Tap 'INSTALLATION CONTROLLER'.
3. Swipe the screen to scroll down and tap 'SCREED DRYING'.
4. Tap 'OFF'.

7.15.3 SCREED DRYING PROGRESS

A counter for the progress for the screed drying can be located within the diagnostics menu of the Aeron Smart Controller.

This is displayed as part of the configured circuit(s) information.

To the diagnostics menu:

1. Tap the Settings menu icon and tap 'USER SETTINGS'.
2. Tap the 'i' symbol. Refer to Figure 7-16.
3. Either Tap the '^' or 'v' arrows or swipe the screen to scroll down to the heating circuit diagnostic information screen. Refer to Figure 7-19.

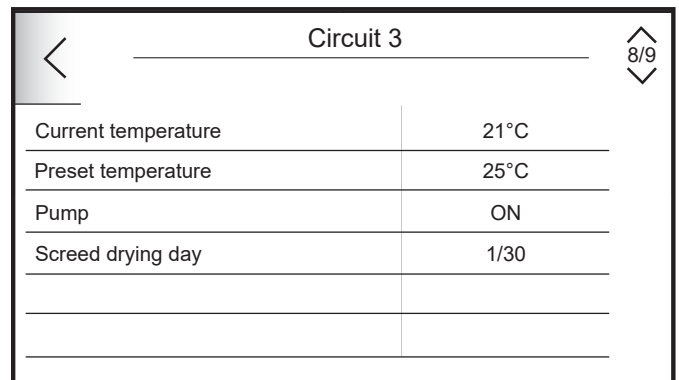
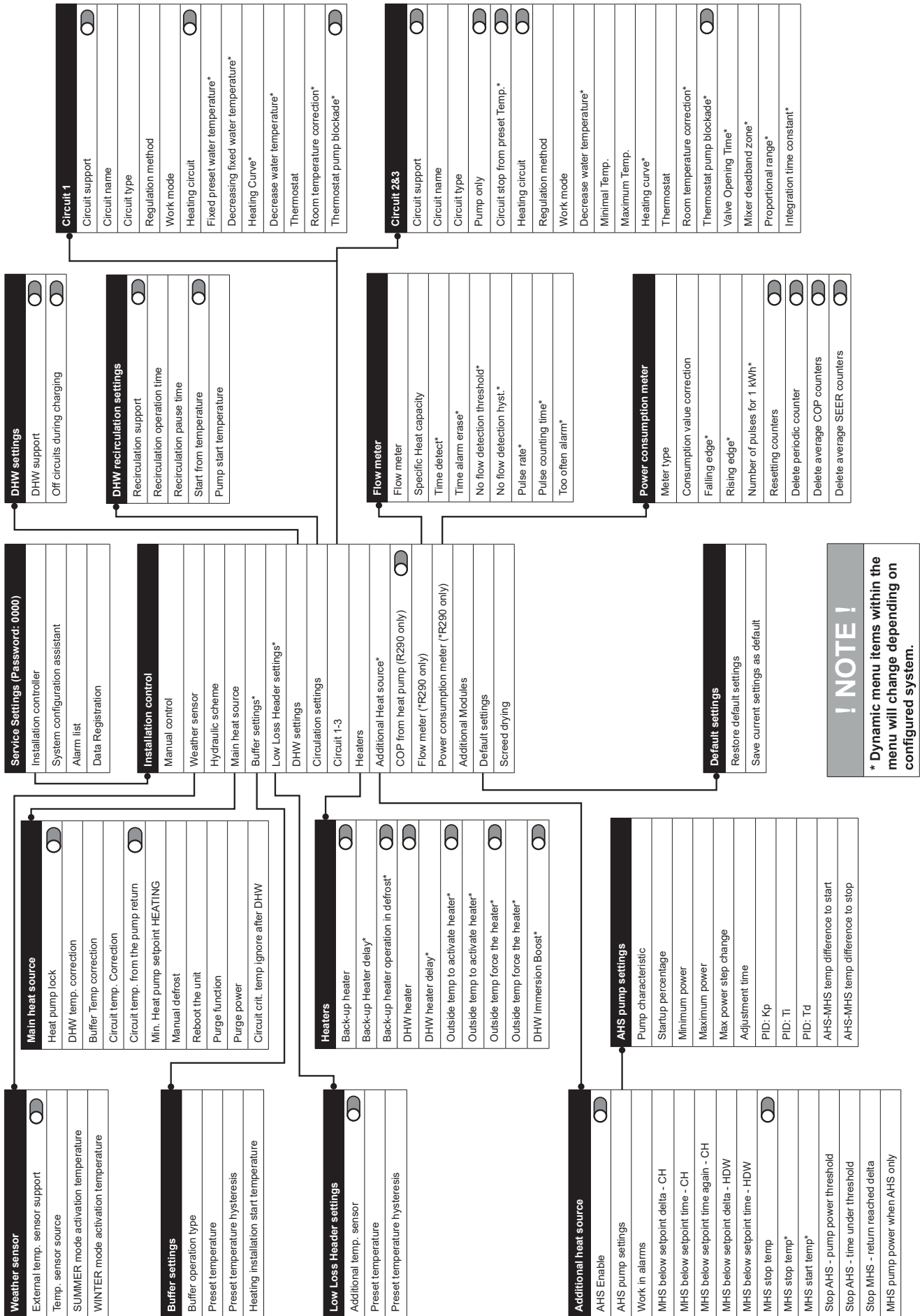

Figure 7-19: Screed drying counter

8 Service Settings



! NOTE !
 * Dynamic menu items within the menu will change depending on configured system.

Figure 8-1: System settings menu map

Prerequisites	Parameter	Description
Service Menu - Top Level		
	Installation controller	Tap the enter System settings list.
	System configuration creator	Tap to begin System configuration creator. Refer to Section 6.
	Alarm List	Tap to view alarm list history.
	Data Registration	Tap to configure Data recording and save to SD card slot.

Installation controller - Manual Control

Manual Control	<p>Tap to enter manual control menu.</p> <ul style="list-style-type: none"> It is possible to activate individual heating system components to conduct operation tests. Turning on or off a particular selected device is done by tapping the symbol on the screen. Note: the controller does not check protection logic, so this menu should be used with awareness of starting outputs in order to avoid damaging the controller and devices connected to its terminals. Long and uncontrolled operation of devices (e.g., pumps) may result in damage.
----------------	--

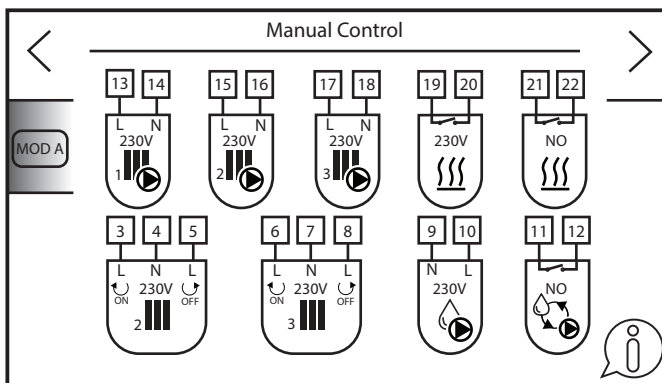

Figure 8-2: Manual Control

Installation controller - Weather Sensor

	External temp sensor support	Tap the toggle icon to activate or deactivate External temp sensor support. (Outdoor Weather sensor). This will be ON if it was configured during System configuration creator.
External temp sensor support: ON	Temp. sensor source	Tap to configure or amend the sensor responsible for monitoring outdoor air temperature. <ul style="list-style-type: none"> Smart Controller - The outdoor weather sensor supplied with the Grant Aerona Smart controller kit. Heat pump - The air temperature sensor installed on the Grant Aerona Heat pump.
External temp sensor support: ON	Summer mode activation temperature	Tap to configure the ambient temperature at which summer mode is activated.
External temp sensor support: ON	Winter mode activation temperature	Tap to configure the ambient temperature at which summer mode is deactivated.

Installation controller - Hydraulic Scheme

		Entering this option will display available options to select. Choose and confirm with ✓. <ul style="list-style-type: none"> Direct - No Hydraulic Separation present. Buffer Low Loss Header
--	--	--

Installation controller - Main Heat Source

	Heat Pump Lock	Tap to toggle Heat pump lock On/Off. Enabling this will open the Volt Free switch in Terminals 23 & 24 to disable heat pump demands.
	DHW Temp correction	Tap to adjust the increase of the target flow for DHW temperature in DHW mode.
Hydraulic Scheme: Buffer/ Low Loss Header	Buffer Temp correction	Tap to adjust the increase of the target flow for the Buffer/Low Loss header temperature when enabled.
	Circuit temp correction	Tap to adjust the increase of the target flow for space heating circuit temperature value in heating mode.
	Circuit temp. from pump return	Tap to toggle for all circuits temperatures to be measured via the heat pump return temperature. Enabling this will negate the need for water temperature sensors for circuit 2 and 3 if not using the mixing functions.
	Min. Heat Pump setpoint HEATING	Tap to configure minimum heat pump flow temperature for heating circuits.
	Manual defrost	Tap to trigger a manual defrost cycle on the unit. (R290 only)
	Reboot the unit	Tap to trigger a power cycle of the unit. (R290 only)
	Purge function	Tap to enable the circulating pump in the unit. (R290 only)
	Purge power	Tap to configure pump speed in the purge function from 0 to 100% (R290 only)
	Circuit crit. temp ignore after DHW	Tap to configure time delay for disabling circuit output if water temperature is above 45°C when underfloor heating is configured (Applicable to Circuits 2 and 3 only)-

Prerequisites	Parameter	Description
Installation controller - Buffer settings		
Hydraulic scheme: Buffer	Buffer operation type	Tap to configure the number of sensors with which the buffer will work. <ul style="list-style-type: none"> One sensor - Water temperature sensor connected to BB terminal. Two sensors. - Water temperature sensors connected to BB & BT terminals.
Hydraulic scheme: Buffer	Preset temperature	Tap to configure target buffer temperature value.
Hydraulic scheme: Buffer	Preset temperature hysteresis	Tap to configure the temperature value drop from preset temperature at which the buffer is heated.
Hydraulic scheme: Buffer	Heating installation start temp	Tap to configure the temperature value at which the circuit pumps will be turned on.
Installation controller - Low Loss Header		
Hydraulic scheme: Low Loss Header	Additional temp. sensor	Tap to enable or disable the water temperature sensor for the Low Loss Header. (Connected to terminal: BB). <i>If disabled, the temperature value is measured from the return temperature on the heat pump.</i>
Hydraulic scheme: Low Loss Header	Preset temperature	Tap to configure the target temperature of the water in the Low Loss Header. <i>If 'ADDITIONAL TEMP SENSOR' is ON, this is measured from terminals 'BB Sensor'</i> <i>If 'ADDITIONAL TEMP SENSOR' is OFF, this is measured from Heat pump return.</i>
Hydraulic scheme: Low Loss Header	Preset water hysteresis	Tap to configure the temperature value drop from 'preset temperature' at which the Low Loss Header is heated.
Installation controller - DHW settings		
	DHW cylinder	Tap the toggle to enable or disable DHW cylinder support.
	Off circuits during charging	Tap to toggle DHW priority On or Off when volumiser/low loss header installed. If set 'OFF', heating circuits remain active in a DHW demand.
Installation controller - Circulation settings We do not recommend the use of Secondary DHW circulation in domestic installations.		
	Circulation support	Tap the toggle icon to activate or deactivate secondary circulation support.
Circulation support: ON	Circulation operation time	Tap to configure the DHW circulation pump operation time. It determines the working time after a break in the circulation pump operation. The DHW circulation pump operates periodically.
Circulation support: ON	Circulation pause time	Tap to configure the DHW circulation pump pause time. Defines the time interval between activations of the circulation pump. The DHW circulation pump operates periodically.
	Start from temperature	Tap the toggle to enable or disable 'PUMP START TEMPERATURE'.
Start from temperature: ON	Pump start temperature	Tap to configure target cylinder temperature threshold to activate the circulation pump. <i>It will be turned off if the temperature of the DHW cylinder is lower than the Pump start temp.</i>
Installation controller - Circuit 1 - (Non-mixing Circuit)		
	Circuit support	Tap the toggle icon to activate or deactivate the circuit support.
	Circuit name	Name of the circuit set by user. Tap to open and adjust.
	Circuit type	Configure the type of heat emitters for the circuit. Tap to open and amend. Circuit 1 is a non-mixing circuit. Radiators or Fan-Coil only.
External temp sensor support: ON	Regulation Method	Tap to configure circuit flow regulation method. <ul style="list-style-type: none"> Fixed - constant set temperature of water in the circuit is maintained. Weather - water temperature is related to Outdoor weather sensor. Outdoor weather sensor required. <i>If "EXTERNAL TEMP SENSOR SUPPORT" is not ON, the Smart controller will only allow fixed circuit flow.</i>
	Work Mode	Tap to amend Heating Circuit work mode. <ul style="list-style-type: none"> OFF Day – Circuit will use higher target circuit temperature. Night – Circuit will use lower target circuit temperature. <i>"DECREASING FIXED WATER TEMPERATURE" or "DECREASE WATER TEMPERATURE" will be applied when the controller is in night mode.</i> <ul style="list-style-type: none"> Schedule – Day or Night mode is set depending on the time schedule.
	Heating circuit	Tap to adjust the space Heating Circuit On or Off.
Regulation Method: Fixed	Fixed preset water temperature	Tap to adjust the fixed preset water temperature for day mode. The Heat pump heats until the fixed preset water temperature is reached.
Regulation Method: Fixed	Decreasing fixed water temperature	Tap to adjust decreasing fixed water temperature. If Regulation method is fixed, this is the value of flow temperature decrease for night mode.
Regulation Method: Weather	Heating Curve	Tap to view and adjust Heating curve for Circuit 1.
Regulation Method: Weather	Decrease water temperature	Tap to view and adjust value of flow temperature decrease when in night mode.
	Thermostat	Displays name of Thermostat currently monitoring the Circuit. Tap to configure thermostat for circuit. <ul style="list-style-type: none"> None Wired - Refer to Appendix A Wireless - Refer to Appendix B Control Panel - Thermostat within the touchscreen display. Contact - External Volt Free contact connection. T1 for circuit 1, T2 for Circuit or 3. Refer to Section 5 for Terminal connections.

Prerequisites	Parameter	Description
Thermostat configured	Room temperature correction	Tap to view and adjust value of automatic correction of room temperature. This is carried out in accordance with the following formula: <ul style="list-style-type: none"> Target temperature with correction = Target air temperature of the thermostat assigned to the circuit minus Current temperature of the thermostat assigned to the circuit x Room temperature correction. By default, the Room temperature correction value is 0, and the value range is 0 - 10. It is necessary to find appropriate value of the Room temperature correction. The higher the coefficient, the greater the correction of target circuit temperature. If the setting is "0", the target circuit temperature is not corrected. Note: setting a value of the room temperature coefficient too high may cause cyclical fluctuations of the room temperature.
Thermostat configured	Thermostatic pump blockade	Tap to toggle circuit pump control status when a thermostat is active for the circuit. Refer to Section 7.8. <ul style="list-style-type: none"> ON - when the target room temperature is met, the circuit pump/valve is disabled. OFF - when the target room temperature is met, the circuit pump/valve is not disabled.
Installation controller - Circuit 2 & 3 - (Mixing Circuit) All options from Circuit 1 are applicable with the below additions.		
	Circuit type	Tap to adjust the circuit heat emitters. <ul style="list-style-type: none"> Radiators Fan-coil Underfloor heating
	Pump Only	Tap the toggle icon to configure Pump only On or Off. <ul style="list-style-type: none"> ON - Mixing Disabled OFF - Mixing Enabled
Pump Only: ON	Circuit stop from Preset Temp	Tap to toggle icon to configure circuit pump control status using Water Temperature sensor on circuit flow. <ul style="list-style-type: none"> ON - when target flow temperature is met, the circuit pump/valve is disabled. OFF - when target flow temperature is met, the circuit pump/valve is not disabled.
	Minimal Temp	Tap to adjust minimum target water temperature into the circuit. Minimum value is determined by 'MIN. HEAT PUMP SETPOINT HEATING'.
	Maximum Temp	Tap to adjust the maximum target water temperature permitted into the circuit. <i>Maximum value is determined by the Heat pump and the circuit type.</i>
Pump only: OFF	Valve Opening Time	Tap to adjust the opening time for connected motorised mixing valve. (Fully closed to fully open)
Pump only: OFF	Mixer deadband zone	Tap to adjust the temperature insensitivity of mixer adjustment.
Pump only: OFF	Proportional Range	Tap to adjust the mixer actuator proportional movement.
Pump only: OFF	Integration time constant	Tap to adjust the time for actuator reaction for temperature deviation.
Installation controller - Heaters (Refer to Appendix D)		
	Back-up heater	Tap the toggle icon to enable or disable the Back-up immersion heater support. <i>Back-up heater support will activate with a Buffer or Low Loss Header configured.</i>
Back-up heater: ON	Back-up heater (delay)	Tap to adjust the delay time for activating the Back-up immersion heater after a heat pump space heating demand starts. A Low Loss Header must be configured for supplementary heating.
Back-up heater: ON	Back-up heater operation in defrost	Tap the toggle icon to enable or disable Defrost support via the Aerona Smart Controller. <i>This will trigger H1 (Terminals 19 & 20) when the heat pump enters a defrost state in any installed systems.</i>
	DHW heater	Tap the toggle icon to enable or disable the DHW Immersion heater support. <i>DHW heater support is required for Legionella protection. Refer to Section 7.4.</i>
DHW heater: ON	DHW heater (delay)	Tap to adjust the delay time for switching on the DHW immersion heater after a DHW demand starts.
Back-up heater: ON and/or DHW heater: ON	Outside temp to activate heater	Tap the toggle icon to enable or disable Outside temp to activate heater. <i>Enabling will create a new selectable box for configuration. (See below)</i>
Outside temp to activate heater: ON	Outside temp to activate heater	Tap to adjust the external temperature value beyond which the DHW heater will be activated.
Back-up heater: ON and/or DHW heater: ON	Outside temp force the heater	Tap the toggle icon to enable or disable Outside temp force the heater. <i>Enabling will create a new selectable box for configuration. (See below)</i>
Outside temp force the heater: ON	Outside temp force the heater	Tap to adjust the external temperature value at which the heater support will be permanently turned on during heat pump operation.
DHW heater: ON	DHW Immersion Boost	Tap to enable DHW Immersion boost for DHW demands. This enables button functionality within DHW work mode settings panel. Refer to Section 7.3.2.2 for further information.

Prerequisites	Parameter	Description
Installation controller - Additional heat source (R290 only - Refer to Appendix J)		
	AHS Enable	Toggle icon to activate or deactivate Additional heat source support. This will be ON if it was configured during System configuration creator.
AHS Enable: ON	AHS Pump settings	Sub menu for PWM pump control. (Refer to Table J-2)
Sub menu - AHS pump settings		
	Pump characteristic	Configure pump type for operation H:Heating S: Solar
	Startup percentage	PWM startup power.
	Minimum power	Minimum power setting of PWM pump
	Maximum power	Maximum power setting of PWM pump
	Max power step change	PWM power adjustment for temperature adjustments
	Adjustment time	Time for PWM power step to be adjusted
	PID: Kp	PID Controller settings
	PID: Ti	
	PID: Td	
	AHS-MHS temp difference to start	Temperature delta between Boiler flow and system flow for PWM pump to start.
	AHS-MHS temp difference to stop	Temperature delta between Boiler flow and system flow for PWM pump to stop.
AHS Enable: ON	Work in alarms	Allow EvoLink Smart to operate when MHS in Alarm state.
AHS Enable: ON	MHS below setpoint delta - CH	Temperature below setpoint MHS needs to achieve in setpoint time for space heating demands
AHS Enable: ON	MHS below setpoint time - CH	Time value in which MHS should reach setpoint delta value for space heating demands
AHS Enable: ON	MHS below setpoint time again - CH	Time value counter from first setpoint in which MHS should reach setpoint delta
AHS Enable: ON	MHS below setpoint delta - HDW	Temperature below setpoint MHS needs to achieve in setpoint time for DHW demands
AHS Enable: ON	MHS below setpoint time - HDW	Time value in which MHS should reach setpoint delta value for DHW demands
AHS Enable: ON	MHS stop temp	Toggle icon to enable MHS shut off at configured temperatures
AHS Enable: ON	MHS stop temp	Temperature value at which the MHS is deactivated for demands
AHS Enable: ON	MHS start temp	Temperature value at which the MHS is activated for demands
AHS Enable: ON	Stop AHS - pump power threshold	PWM pump speed to start under threshold counter to turn of AHS during a demand for space heating
AHS Enable: ON	Stop AHS - time under threshold	Time counter for pump power threshold to be under value to turn off AHS during a demand for space heating
AHS Enable: ON	Stop MHS - return reached delta	Temperature value of delta between return flow temperature to MHS and maximum Flow temperature to stop MHS compressor
AHS Enable: ON	MHS pump power when AHS only	MHS PWM pump speed when AHS only.
Installation controller - Power Consumption meter		
	Meter type	Entering this option will display available options to select. Choose and confirm with ✓. <ul style="list-style-type: none"> • None • Pulse • Heat Pump
Meter type: pulse or heat pump	Consumption value correction	Value correction of energy reading in watts.
Meter type: pulse	Falling edge	Tap to configure counting pulses on the falling edge of the signal.
Meter type: pulse	Rising edge	Tap to configure counting pulses on the rising edge of the signal.
Meter type: pulse	Number of pulses for 1kW/h	Tap to configure the number of pulses as per 1kW/h of electricity consumed.
Meter type: pulse or heat pump	Resetting counters	Toggle to reset of counters for COP and EER.
Meter type: pulse or heat pump	Delete periodic counter	Toggle to reset the pulse counter that counts the periodic consumed electric energy.
Meter type: pulse or heat pump	Delete average COP counters	Toggle to reset the counters for the coefficient of performance in heating mode.
Meter type: pulse or heat pump	Delete average SEER counters	Toggle to reset the counters for the electricity consumption efficiency in heating mode.

Prerequisites	Parameter	Description
Installation controller - Flow meter (Refer to Appendix E)		
	Flow meter	Tap to select the flow meter required. <i>Choose from available options and confirm with ✓.</i> <ul style="list-style-type: none"> • Default • Pulse
Flow meter: Default	Default flow meter	Tap to configure the default flow in the circuit. When exceeded, a no-flow alarm will be reported.
	Specific Heat capacity	Tap to configure the coefficient of liquid used to transfer heat in the heating circuits.
	Time detect	Tap to configure the time after which the no-flow alarm will be reported.
	Time alarm erase	Tap to configure the time after which the no-flow alarm will be reset. <i>The controller will not report an alarm.</i>
	No flow detection threshold	Tap to configure the flow value below which the alarm "Flow error" will be reported.
	No flow detection hysteresis	Tap to configure the No Flow detection hysteresis value at which the alarm will be turned off. <i>If the actual flow rises above the value of No flow detection threshold plus No flow detection hysteresis.</i>
Flow Meter: Pulse	Pulse rate	Tap to configure the Flow sensor pulse rate to calculate flow.
Flow Meter: Pulse	Pulse counting time	Tap to configure the Flow sensor pulse count time duration.
	Too often alarm	Tap to configure the too frequent no-flow alarm detection threshold to limit the frequent reporting of the no-flow alarm.
Installation controller - COP from heat pump (R290 only)		
	COP from heat pump	Tap to toggle COP to be calculated from heat pump readings ON or OFF. If this is enabled it will remove 'Flow sensor' and Power consumption meter' menus from the list. Readings can be viewed from the diagnostic menu in user settings.
Installation controller - Default Settings (Refer to Section 7.10)		
	Restore default settings	Tap to recall and apply previously saved default settings.
	Save current settings as default	Tap to save current settings as default. This will save the current setup of the Grant Aerona Smart controller to memory.
Installation controller - Screed drying (Refer to Section 7.15)		
	Screed drying	Tap to trigger the pre-programmed screed drying function.

! NOTE !

During the initial setup the smart controller disables support for all heating circuits, DHW cylinder, volumiser, and circulation pumps. Depending on the hydraulic system used, these circuits must be turned on.

! NOTE !

We do not recommend the use of Secondary DHW circulation in domestic installations.

! NOTE !

Only microSD HC memory card (max. 32 GB, FAT32 file format) can be used with the Aerona Smart controller.

9 Heat Pump Parameters

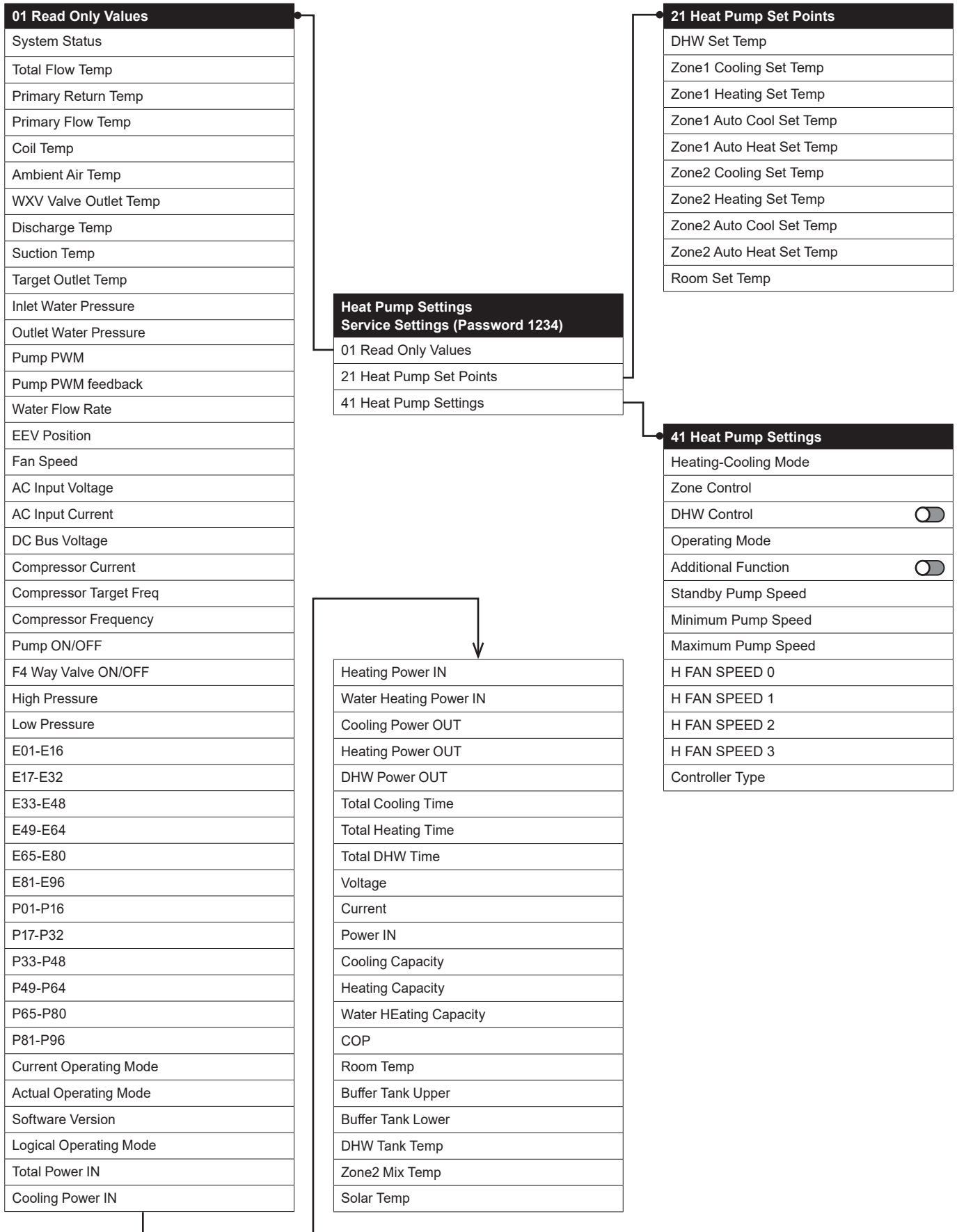

Figure 9-1: Heat pump parameters menu

10 Wi-Fi Hub

10.1 GENERAL

The Wi-Fi hub enables the Grant Aeron Smart Controller to be accessed and operated remotely via the Internet or app. Users can monitor the operation of the Grant Aeron Smart controller and modify some operation parameters with the use of a computer, Tablet or mobile phone. Essential features of the module include:

- Communication with econet24.com external server provides access to Smart Controller via Internet.
- Support Wi-Fi wireless network access.
- Preview of the current operation parameters of the Smart Controller in readable and clear “tiles”.
- Visual diagrams indicating current operation of the installed hydraulic system.
- Preview and edit options of most user and service parameters of the controller.
- Registration of operation parameters and alarm conditions of the controller.
- E-mail notifications of alarm conditions of the main controller.

The mobile app is available from Google play or IOS store and can be downloaded using the QR codes below.



ecoNET.apk (Android)



ecoNET.app (IOS)

10.2 CONNECTION TO WIRING CENTRE

The hub has to be connected with G3 socket on the wiring centre with the use of ecoLINK interface cable. The ecoLINK interface cable and adapter are a part of the Wi-Fi hub set within your Grant Aeron Smart controller kit.

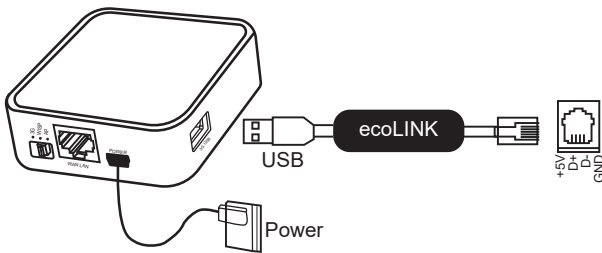

Figure 10-1: ecoLINK Cable connection

Connect the power adapter plug to the mini USB Port socket and 3G USB Port to the ecoLINK interface. A Ethernet cable will be required between the RJ45 Ethernet Port and ADSL router, switch and modem. The ethernet cable does not have to be used if connected via Wi-Fi wireless network access.

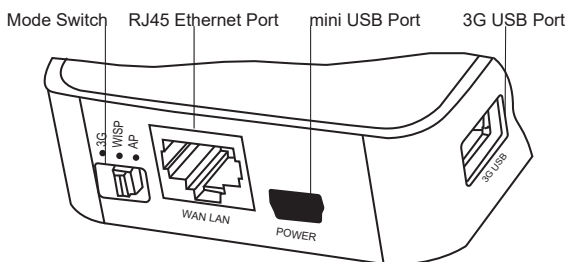

Figure 10-2: Connection ports

The Mode Switch can be set in any position.

After the power is on, hub requires approx. 1 minute in order to load the operational system. The module will then indicate its condition via the LED. In a connection between hub with a main controller is active, a “connection with controller” indicator lights up.

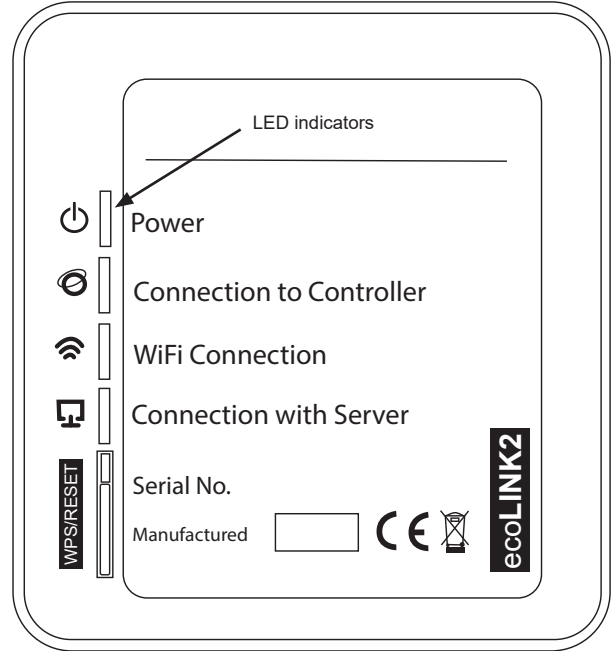

Figure 10-3: Web Module

Table 10-1: LED description

LED	ON/OFF Condition
	Status of Power.
	Active connection to the Aeron Smart Controller.
	Connection to Wireless Network
	Connection to econet24 external server

! NOTE !

The Wi-Fi hub requires active DHCP server connection (as is standard with most household routers). Manual IP assignment for the hub is not supported.

If you should experience any issues during setup or the user forgets their details for logging in the Wi-Fi hub, it is possible to restore default data with the use of the WPS/Reset button on the hub housing.

- Push and hold 'WPS/RESET' for at least 10 seconds.
- Release the 'WPS/RESET' button. LED indicator above should flash several times.
- Wait for approx. 2 minutes.
- The hub will automatically start up and connect with the Internet using default username (**admin**) and password (**admin**).

Wi-Fi access parameters will need to be entered into the touchscreen display via the User settings menu for the hub to be able to make a wireless connection. (Refer to Section 7.9 and 10.3)

10.3 CONNECTION TO INTERNET

The supplied Wi-Fi hub will need to be connected to the internet via either an Ethernet cable between a router and the hub or via Wi-Fi.

10.3.1 USE THE ECONET CONFIGURATION WIZARD

The ecoNET configuration wizard is either accessed via the System configuration creator (on first power on) or from the user settings menu (Refer to Section 7.9).

After you have begun the configuration wizard:

1. Tap '>' to confirm to proceed.
2. Follow the steps displayed to connect the Wi-Fi hub to the wiring centre (if this has not already been done) and tap '>' to confirm.
3. The touchscreen display will confirm if the Wi-Fi hub has been successfully connected. Tap '>' to proceed.
4. Select your preferred connection method:
 - Ethernet - Ethernet cable connection between router and Wi-Fi hub.
 - Wi-Fi - Wireless connection between router and Wi-Fi hub.

If ethernet selected:

5. Follow the steps displayed to connect the ethernet cable to the Wi-Fi hub (if this has not already been done) and tap '>' to confirm connection.
6. The smart controller will automatically perform a test for connection status to the ecoNET external server. The touchscreen will display confirmation connection once this has been made.

If Wi-Fi selected:

5. Fill in required information by tapping boxes to open on-screen keyboard to input.
 - SSID - Name for the Wi-Fi network the hub is required to connect to.
 - Password - Password to access the Wi-Fi network.
 - Type of Security - Wi-Fi security protocol the router uses. WPA 2 is the most commonly utilised.

! NOTE !

Take care to tap '<' to confirm input parameters via the on-screen keyboard. To go back tap 'v'

6. Tap 'PERFORM A CONNECTION TEST' to test for connection status to the ecoNET external server. The touchscreen will display confirmation connection once this has been made.

! NOTE !

It may take time to authenticate a Wi-Fi connection. Allow time for IP address synchronisation with the router (Up to 5 minutes if first attempt to connect fails).

10.3.1.2 WI-FI MANUAL CONFIGURATION

To configure Wi-Fi access manually, navigate to the user settings menu and select the Radio Icon (Refer to Section 7.9).

1. Tap 'Wi-Fi setting'.
2. Enter the required information by tapping each box to display the on-screen keyboard to input.
 - SSID - Name for the Wi-Fi network the hub is required to connect to.
 - Password - Password to access the Wi-Fi.
 - Type of Security - Wi-Fi security protocol the router uses. WPA 2 is the most commonly utilised.

! NOTE !

The wireless router is only compatible with a 2.4GHz wireless signal.

10.3.2 HOW TO CHECK CONNECTION STATUS

Follow the steps to check the connection status with ecoNET24 services on the touchscreen display.

1. When the heating circuit control interface is shown (see Figure 7-1), tap settings menu. Refer to Table 7-1 and Figure 10-4.

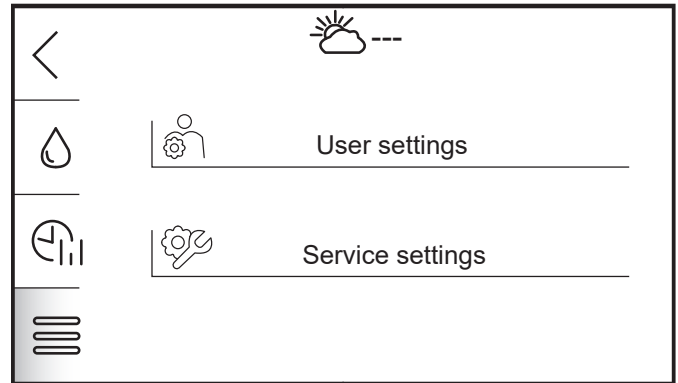

Figure 10-4: Settings selection

2. Tap 'USER SETTINGS'. Refer to Figure 10-5.

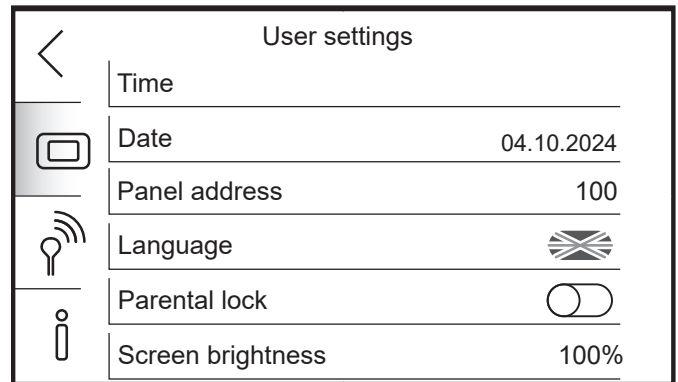

Figure 10-5: User settings menu

3. Tap the Wi-Fi icon on the left. Refer to Figure 10-6.

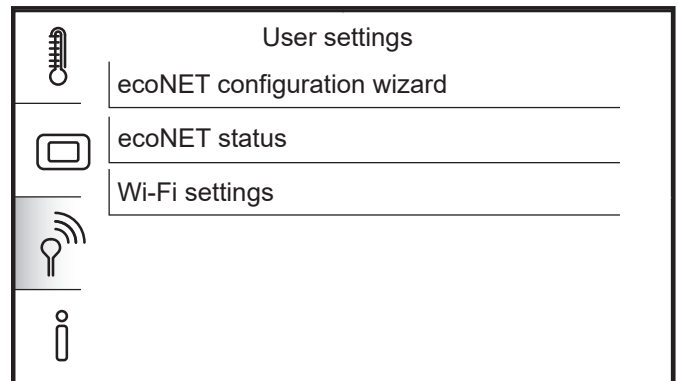

Figure 10-6: ecoNET connection options.

4. Tap 'ECONET STATUS'. Refer to Figure 10-7 for connection status display.

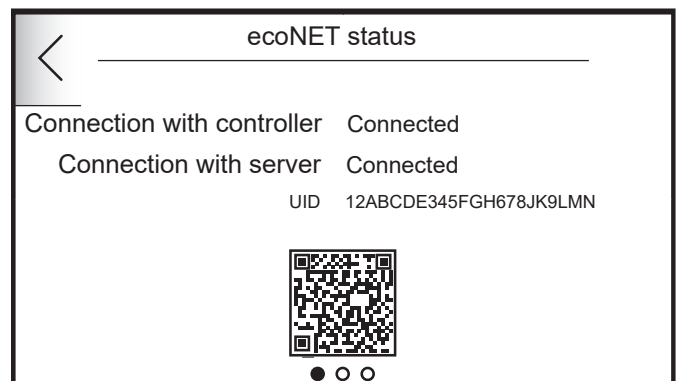

Figure 10-7: ecoNET connection status

11 Servicing

11.1 COMPONENT REPLACEMENT

11.1.1 MAIN FUSE

The main fuse is located under the wiring centre cover, next to the terminals on the high-voltage side. This is a 250V 5 x 20mm 6.3A 'T' type AC fuse. A spare fuse is located under the cover of the wiring centre on the low-voltage terminals side.

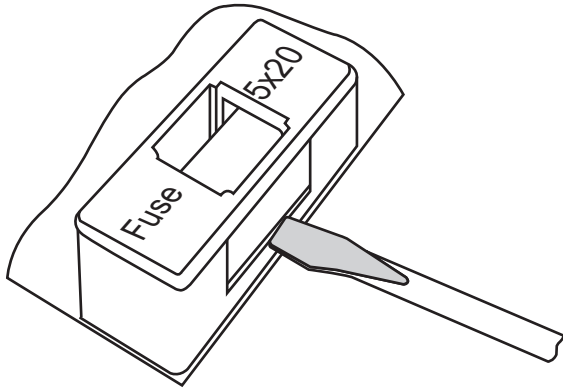

Figure 11-1 Mains fuse replacement

In order to remove fuse lift fuse holder with flat-blade screwdriver and pull out the fuse. Refer to Figure 11-1.

11.1.2 TOUCHSCREEN DISPLAY REPLACEMENT

When replacing the touchscreen display make sure that its software is compatible with software in the wiring centre. The compatibility is kept if the first number of software in the touchscreen display and wiring centre are the same.

11.1.3 WIRING CENTRE REPLACEMENT

Requirements are analogous to the control panel.

11.2 ACCESSORIES & SPARE PARTS

Grant UK offer the individual components to the Smart Controller system should the need arise.

Table 11-1: Accessories & Spare Parts List

Item	Part Code
Wireless thermostat (with receiver)	HPIDSMARTWRTR
Wireless thermostat (no receiver)	HPIDSMARTWRT
Wireless thermostat receiver	HPIDSMARTRECEIVER
Wired thermostat	HPIDSMARTHRT
Water temperature sensor with 2m cable*	HPIDSMARTSEN2
Water temperature sensor with 4m cable*	HPIDSMARTSEN4
Outdoor Weather Sensor*	HPIDSMARTWSEN
Smart Flow sensor* (Aerona ³ only)	HPIDSMARTFLO
Immersion Heater Relay	HPIDSMARTIMM
Smart Controller Wi-Fi Hub*	HPIDSMARTHUB
3-Port Diverter valve**	HPID120
3-Port Valve body**	HPID122
Motorised valve actuator**	HPID123X

* - supplied as part of Aerona Smart controller kit

** - supplied as part of a Aerona Smart controller installation pack

11.3 UPDATING CONTROLLER SOFTWARE

Software updates can be performed using only microSD HC memory card (max. 32 GB, FAT32 file format).

The memory card should contain new software in *.pfc format for the control panel and *.pfi format for the controller module. New software should be placed directly on memory card with no folders or sub-folders.

! NOTE !

Before starting software updates, all peripheral devices operating with the Smart Controller must be disconnected from electric power supply.

In order to update software:

1. Insert memory card into the SD card socket on the touchscreen display. Refer to Figure 11-2.

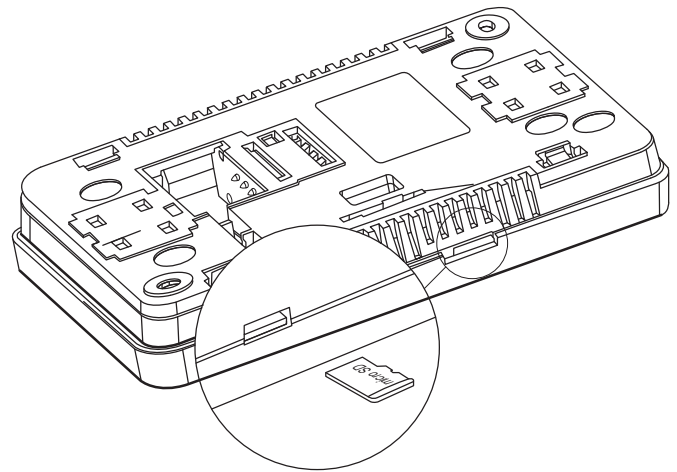

Figure 11-2 Memory card slot

! CAUTION !

Incompatibility of software between the touchscreen display and wiring centre may cause unexpected errors. The manufacturer is not responsible for malfunctions caused as a result of using incompatible software by the end-user.

2. Reconnect the electric power supply to the controller and turn on.
3. Tap settings menu. Refer to Table 7-1 and Figure 11-3.

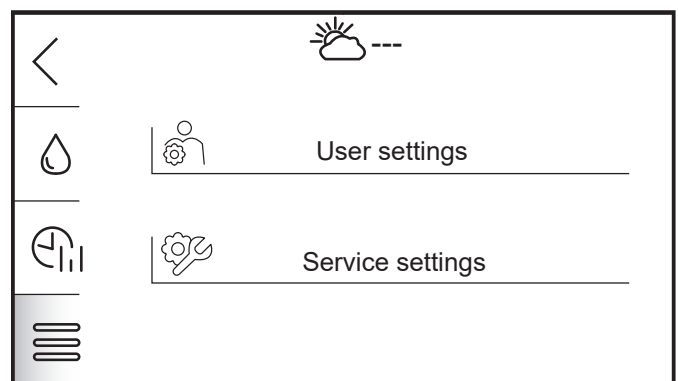

Figure 11.3: Settings selection

4. Then tap the User settings. Refer to Figure 11-4.

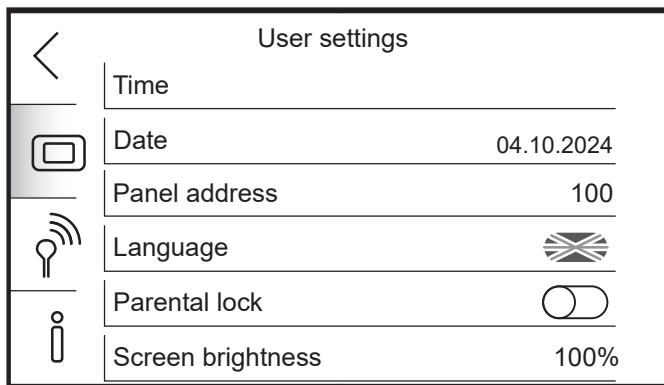

Figure 11-4: User settings menu

5. Tap the information icon at the bottom. Refer to Figure 11-5.

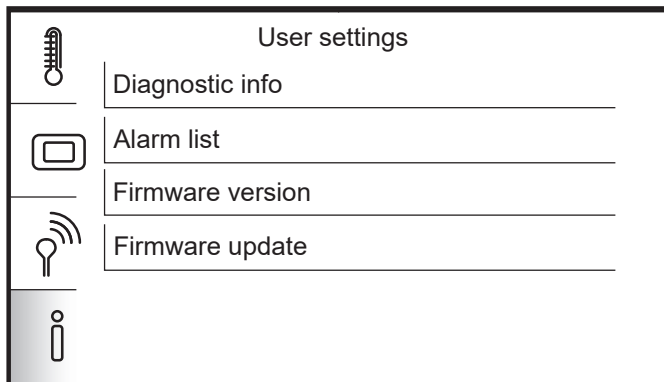

Figure 11-5: Controller information options.

6. Tap 'FIRMWARE UPDATE'.
7. Tap 'CONTROLLER'.



8. The screen will display the versions of software that are both installed (Current) and on the SD card (New) with a prompt at the bottom to 'INSTALL NEW PROGRAM'. Tap the Green '✓' to install.
9. Once the controller software is updated a prompt is displayed. Confirm by tapping '✓' and the controller will restart.
10. Follow steps 3-6 and then tap 'PANEL'. Step 8 will be repeated and once confirmed the controller will update and automatically restart.
11. On completion, the touchscreen display will confirm the update is complete and to remove the SD card. Once removed tap '✓' and the Smart Controller will start.
12. After any software update, we advise the controller be factory reset.
13. Tap settings menu. Refer to Table 7-1 and Figure 11-3.
14. Tap 'SERVICE SETTINGS' and enter the password "7586" and then enter to confirm.
15. Tap "RESTORE DEFAULT SETTINGS' and confirm by tapping '✓'
16. When confirmation message is displayed, power off the wiring centre with the rocker switch on the side.
17. Wait apx. 10 seconds and then power the wiring centre on.

12 Fault Finding

Should there be a fault with the smart controller, the heat pump or some of its connected components, the alarm icon will be displayed on the smart controller touchscreen display when viewing a heating or DHW circuit.

Tapping the icon will display a list of the current and historical alerts. Refer to Table 7-1 for more information.

If a wired or wireless thermostat is configured, this will also display an alarm code. Refer to Appendix A & B for thermostat alarm code lists.

12.1 ALARMS

12.1.1 TEMPERATURE SENSOR ERRORS

If the alarm is an error for Circuit (Circuit 2 or 3), outdoor temperature, upper/lower buffer water or DHW cylinder temperature sensor, you should:

- check the temperature sensors are connected correctly to the wiring centre. These will be connected between terminals 38 and 50 of the wiring centre (15V DC). Refer to Section 5.4
- check for loose connections on the sensors and wiring centre terminals.
- check the sensors have been installed correctly and are not damaged.
- check the sensors have been installed as per the system scheme. (e.g., Outdoor temperature sensor has been configured but not installed as the heat pump was intended to be used).

12.1.2 NO CONNECTION TO HEAT PUMP

If the alarm is 'No communication with the heat pump module', you should:

- check the heat pump had power and the isolator is set to ON.
- check that both the connection and polarity of the wires for the Modbus connection between the wiring centre and the heat pump are correct.

Refer to Section 3.12 for Modbus connection between the heat pump and wiring centre.

12.1.3 NO FLOW DETECTED

If the alarm is 'No Flow detected', you should:

- check the Smart flow sensor is connected to the Smart controller wiring centre correctly.
- check the Smart flow sensor is configured correctly on the Smart controller. Refer to Appendix E.
- check the heat pump is working correctly.

12.2 THERMOSTATS

For issues when attempting to pair or use additional thermostats on the smart controller, you should:

- check that the wired thermostat or wireless receiver has been connected correctly to the G1 socket.

- check the wireless thermostat has been paired. Refer to Appendix B.3.2 and A.1 for thermostat status information from the display.
- check the thermostats are paired to the space heating circuit.
- ensure thermostat addresses are different if multiple wireless thermostats are being used, and you have the correct thermostat for the circuit. Refer to Appendix B.3.2 and B4.

12.3 ECONET

The smart controller will give an indication on the touchscreen display of the status of connection with the Econet24 external services via the Econet cloud icon. Refer to Figure and Table 7-1 If the symbol is 'green', the smart controller has an active connection to the ecoNET24 server.

If the symbol is red, the smart controller does not have an active connection to the ecoNET24 server.

The first step will be to check the Wi-Fi hub. The LED indicators on the front will aid in deciphering the issue.

Refer to Table 12-1 for information on LED indicators and how to resolve faults.

Refer to Section 10 for further information on the Wi-Fi hub and connection to the wiring centre.

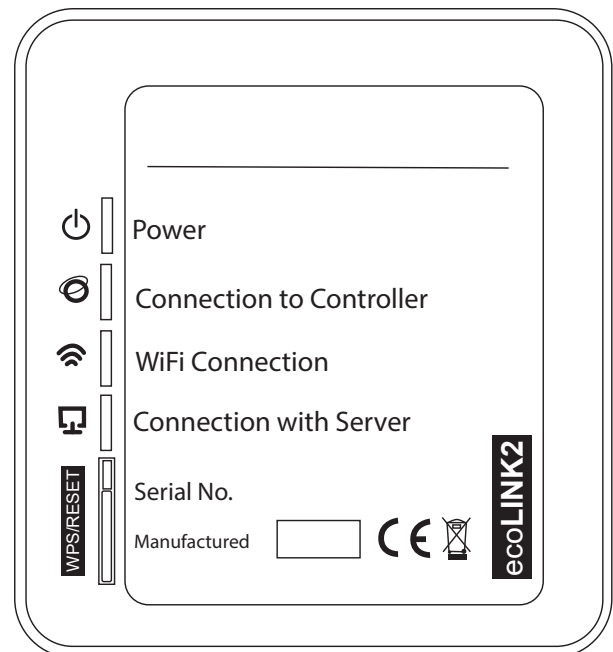

Figure 14-1: Web Module

Table 12-1: LED description

LED Label	Indicator name	Resolution
	Status of Power.	Check Power supply cable is connected to source correctly. Check power supply cable is secure in the Wi-Fi Hub. Check power supply cable is not damaged.
	Active connection to the Aeron Smart Controller.	Check the ecoLINK cable is connected securely in the Wi-Fi hub. Check the ecoLINK cable is connected to the wiring centre correctly. Check the ecoLINK cable is not damaged.
	Connection to Wireless Network	Check the Wi-Fi router is on. Check the Wi-Fi settings on the Smart controller are correct.
	Connection to ecoNET24 external server	Ensure the UID is registered to a ecoNET24 user account. Visit www.econet24.com to register. Refer to Appendix H for more information on ecoNET24.

13 EC Declarations of Conformity



UKCA - Safety Declaration of Conformity

This declaration is made under the sole responsibility of the following Manufacturer. The Manufacturer declares that the following product conforms to the requirements of the UK Legislation and Regulations as detailed below.

The Technical Construction Files are retained at the Manufacturer's location.

Product: Grant Smart Controls

Model: GRANTSMARTCONKIT

In accordance with the following directive(s) or Regulation(s), provided that the products are installed and used in accordance with our instructions:

S.I. 2016/1101: Electrical Equipment (Safety) Regulations 2016

S.I. 2016/1091: Electromagnetic Compatibility Regulations 2016

S.I. 2012/3032: The Restriction of the Use of Certain Hazardous Substances in Electrical and Electronic Equipment Regulations 2012

following the provisions of:

BS EN 60730-2-9:2010

BS EN 660730-1:2016-A1:2019 BS EN 50581: 2012

Directive 2012/19/EU WEEE Directive

Directive 2014/53/EU Radio Equipment Directive

Place of Issue
Date of issue

United Kingdom
13 December 2023

Technical File Compiler
and Authorised Signatory

A handwritten signature in black ink, appearing to read "Neil Sawers", written over a light blue horizontal line.

Neil Sawers
Commercial Technical Manager

Grant Engineering (UK) Ltd

Frankland Road | Blagrove | Swindon | SN5 8YG

+44(0)1380 736920 | info@grantuk.com | www.grantuk.com

REGISTERED IN ENGLAND No: 3196757. REGISTERED OFFICE: AS ABOVE

GUK13122023 UKCA DoC GSKC

14 Health and Safety Information

14.1 GENERAL

The Health and Safety information given in this Section relates to the Grant Aeronas smart controller only.

For details of the Health and Safety Information for the heat pump, refer to Section 14 of the Aeronas³ installation and servicing instructions supplied.

For details of the Health and Safety Information for any other heating appliances being used, refer to the instructions supplied with the appliance.

Under the Consumer Protection Act 1987 and Section 6 of the Health & Safety at Work Act 1974, we are required to provide information on substances hazardous to health (COSHH Regulations 1988).

15 Disposal and Recycling

15.1 DIRECTIVE WEEE 2012/19/EU

Purchased product is designed and made of materials of the highest quality.

The product meets the requirements of the Directive 2012/19/EU of 4 July 2012 on waste electrical and electronic equipment (WEEE), according to which it is marked by the symbol of crossed-out wheeled bin (like below), meaning that product is subjected to separate collection.

Responsibilities after finishing a period of using product:

- Dispose of the packaging and product at the end of their period of use in an appropriate recycling facility,
- Do not dispose of the product with other unsorted waste,
- Do not burn the product.
- By complying with the above obligations of controlled disposal of waste electrical and electronic equipment, you avoid harmful impact on the natural environment and threats to human health.

16 Guarantee

You are now the proud owner of an Aerona Smart Controller for use with the Grant Aerona Air Source Heat Pump which has been designed to give years of reliable, trouble free operation.

Grant Engineering (UK) Limited guarantees the manufacture of the Aerona Smart Controller including all electrical and mechanical components supplied with it for a period of **twelve months from the date of installation**⁴, provided that the Smart Controller and the air source heat pump with which it is being used have been installed in full accordance with the installation and operating instructions issued.

This will be extended to a total period of **two years** if the Smart Controller is registered with Grant Engineering (UK) Limited **within thirty days of installation**⁴, and it is checked, along with the associated valves, sensors, etc. when the heat pump is serviced at twelve monthly intervals³. See main Terms and Conditions below.

Registering the product with Grant Engineering (UK) Limited

Please register your Smart Controller with Grant Engineering UK Limited **within thirty days of installation**. To do so visit www.grantuk.com and click the 'Register Product' link in the top right-hand corner of the home page, where you can register your Smart Controller for a further **twelve months** guarantee (giving **two years** from the date of installation). This does not affect your statutory rights¹.

If a fault or defect occurs within the manufacturer's guarantee period

If your Smart Controller should fail within the guarantee period, you must contact Grant Engineering (UK) Limited, who will arrange for the repair under the terms of the guarantee, providing that the Smart Controller and the heat pump with which it is being used have been correctly installed, commissioned and serviced (if the appliance has been installed for more than twelve months) by a competent person and the fault is not due to tampering, system water contamination, misuse, trapped air or the failure of any external components not supplied by Grant Engineering (UK) Limited, e.g. pipework, etc.

This two-year guarantee only applies if the Smart Controller is registered with Grant Engineering (UK) Limited within thirty days of installation⁴ and is checked along with the associated valves, sensors, etc. when the heat pump is serviced after twelve months.

In the first instance

Contact your installer or commissioning engineer to ensure that the fault does not lie with the system components, discharged batteries in wireless thermostats, or any incorrect settings of the Smart Controller that falls outside of the manufacturer's guarantee otherwise a service charge could result. Grant Engineering (UK) Limited will not be liable for any charges arising from this process.

If a fault covered by the manufacturer's guarantee is found

Ask your installer to contact Grant Engineering (UK) Limited, Service Department on +44 (0)1380 736920 who will arrange for a competent service engineer to attend to the fault.

Remember - before you contact Grant Engineering (UK) Limited

Ensure the Smart Controller and the air source heat pump with which it is being used have been installed, commissioned and serviced by a competent person in accordance with the installation and operating instructions.

Ensure the problem is not being caused by the heating system, discharged batteries in wireless thermostats, incorrect settings of the controls or any controls not supplied by Grant Engineering (UK) Limited.

Free of charge repairs

During the **two year** guarantee period no charge for parts of labour will be made, provided that the Smart Controller and the air source heat pump with which it is being used have been installed and commissioned correctly in accordance with the manufacturer's installation and operating instructions, it was registered with Grant Engineering (UK) Limited within thirty days of installation⁴ and, for Smart Controllers and air source heat pumps over twelve months old, details of annual service is available³.

The following documents must be made available to Grant Engineering (UK) Limited on request:

- Proof of purchase
- Commissioning Report Form
- Service documents
- System Design Criteria

Chargeable repairs

A charge may be made (if necessary following testing of parts) if the cause of the breakdown is due to any fault(s) caused by the plumbing or heating system, e.g. contamination of parts due to system contamination, sludge, scale, debris or trapped air. See 'Extent of manufacturer's guarantee' below.

Extent of manufacturer's guarantee:

The manufacturer's guarantee does NOT cover the following:

- If the Smart Controller has been installed for over two years.
- If the Smart Controller and/or the air source heat pump with which it is being used have not been installed, commissioning, or serviced by a competent person in accordance with the installation and operating instructions.
- The serial number has been removed or made illegible.
- Fault(s) due to accidental damage, tampering, unauthorized adjustment, neglect, misuse or operating the Smart Controller and/or the air source heat pump contrary to the manufacturer's installation and operating instructions.
- Damage due to external causes such as bad weather conditions (flood, storms, lightning), fire, explosion, accident or theft.
- Fault(s) due to incorrectly sized expansion vessel(s), incorrect vessel charge pressure or inadequate expansion on the system.
- Fault(s) caused by external electrics and external components not supplied by Grant Engineering (UK) Limited.
- Air source heat pump servicing, de-scaling or flushing.
- Checking and replenishing system pressure.
- Electrical cables and plugs, external controls not supplied by Grant Engineering (UK) Limited.
- Heating system components, such as radiators, pipes, fittings, pumps and valves not supplied by Grant Engineering (UK) Limited.
- Instances where the Smart Controller has been un-installed and re-installed in another location.
- Use of spare parts not authorised by Grant Engineering (UK) Limited.
- Consumable items including, but not limited to, batteries, antifreeze and biocide inhibitor.
- The replacement of batteries in wireless thermostat.
- The cost and provision of any specialist access equipment, or any associated costs, required to inspect, repair, service or replace any units not installed in accordance with these installation instructions, irrespective of whether the heat pump is deemed to be at fault or not.

Terms of manufacturer's guarantee

The Company shall mean Grant Engineering (UK) Limited.

The Smart Controller and the heat pump with which it is being used must be installed by a competent installer and in full accordance with the relevant Codes of Practice, Regulations and Legislation in force at the time of installation.

The Smart Controller is guaranteed for two years from the date of installation⁴, providing that after twelve months the annual service has been completed³ and the heat pump registered with the company within thirty days of the installation date⁴. Any work undertaken must be authorised by the Company and carried out by a competent service engineer.

Proof is provided that the system has been flushed or chemically cleaned where appropriate (refer to BS 7593) and that the required quantity of a suitable corrosion inhibitor added.

Proof of annual servicing (including the checking of any expansion vessels and pressure relief valves) must be provided if and when requested by the Company.

IMPORTANT Grant Engineering (UK) Limited **strongly recommends** that a Grant Mag-One in-line magnetic filter/s (or equivalent⁶) is fitted in the heating system pipework. This should be installed and regularly serviced in accordance with the filter manufacturer's instructions.

This guarantee does not cover breakdowns caused by incorrect installation, neglect, misuse, accident or failure to operate the Smart Controller and/or heat pump in accordance with the manufacturer's installation and operating instructions.

The Smart Controller is registered with the Company within thirty days of installation. Failure to do so does not affect your statutory rights¹.

The balance of the guarantee is transferable providing the installation is serviced prior to the dwelling's new owners taking up residence. Grant Engineering (UK) Limited must be informed of the new owners's details.

The company will endeavour to provide prompt service in the unlikely event of a problem occurring but cannot be held responsible for any consequences of delay however caused.

This guarantee applies to Grant Engineering (UK) Limited Smart Controllers purchased and installed on the UK mainland, Isle of Wight, Channel Islands and Scottish Isles only². Provision of in-guarantee cover elsewhere in the UK is subject to agreement with the company.

All claims under this guarantee must be made to the Company prior to any work being undertaken. Invoices for call out/repair work by any third party will not be accepted unless previously authorised by the Company. Proof of purchase and date of installation, commissioning and service documents must be provided on request.

If a replacement Smart Controller is supplied under the guarantee (due to a manufacturing fault) the product guarantee continues from the installation date of the original Smart Controller and not from the installation date of the replacement⁴.

- The replacement of a Smart Controller under this guarantee does not include any consequential costs.

Foot notes

1. Your statutory rights entitle you to a one-year guarantee period only.
2. The UK mainland consists of England, Scotland and Wales only. Please note that for the purposes of this definition, Northern Ireland, Isle of Man and Scilly Isles are not considered part of the UK mainland.
3. We recommend that your Smart Controller and the air source heat pump with which it is installed are serviced every twelve months (even when the guarantee has expired) to prolong the lifespan and ensure it is operating safely and efficiently.
4. The guarantee period will commence from the date of installation, unless the installation date is more than six months from the date of purchase, in which case the guarantee period will commence six months from the date of purchase.
5. As measured by gauss. The Mag One Duo magnetic filter has a Gauss measurement of 12000.

Version 1.0 - December 2023

Appendix A Wired Thermostat

A.1 GENERAL

The Grant Wired thermostat is designed to provide individual circuit control via the Grant Aeronia Smart Controller.

The thermostat is installed in a suitable location to monitor the circuit, e.g., Ground floor hallway, and is designed to maintain a target temperature.

The thermostat on the backlit LCD display shows information about the circuit temperature value, selected operating mode, current time with simultaneous clock synchronization with the main controller.

A.2 INSTALLATION

The thermostat is intended for installation only in a dry, habitable location and should be mounted to the wall. After choosing the place of installation, make sure that:

- The selected location is free of excessive humidity and the ambient temperature of the thermostat should be within the range of 0 to 40°C,
- The chosen location should ensure free air circulation and should be located away from heat-emitting sources, e.g., electronic equipment, fireplace, heater and direct sunlight.
- The thermostat should be mounted at a height enabling convenient operation, typically 1.5m above the floor. (Refer to Figure 3-1)

The thermostat should be screwed to the wall with mounting screws. Access to the screw holes is obtained by opening and removing the back cover of the thermostat. A flat screwdriver can be used to open the cover.

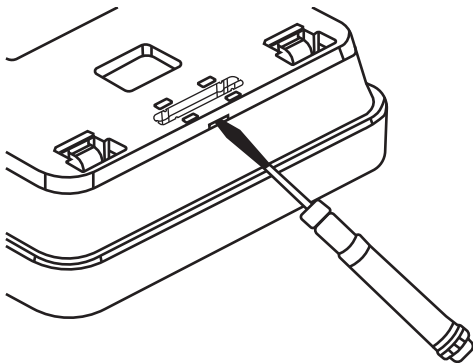

Figure A-1: Wired thermostat back access

The cover is screwed to the selected location of the wall with the appropriate position (UP), as shown in the Figure below. The hole spacing can be determined by attaching the cover to the wall.

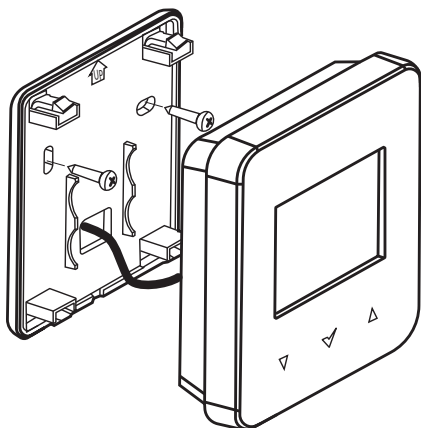

Figure A-2: Wired thermostat wall fixing

Before reattaching the cover, lead the wire connecting the thermostat with the wiring centre through the hole. The cable must be recessed into the wall. The cable can not be routed together with the electrical cables of the building. The cable should not run in the vicinity of devices emitting strong electromagnetic fields. Then attach the thermostat to the mounting frame using the clips.

The VCC, GND, D+, D- terminals of the thermostat should be connected to the G1 socket of the main controller. Refer to Figure A-3.

! NOTE !

A 4-core cable with a cross-Section of min. 0.5 mm².

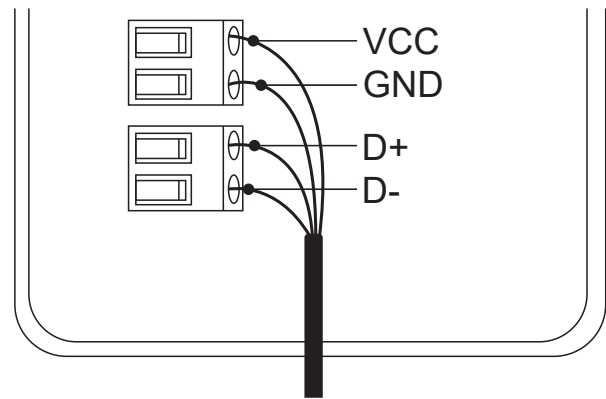

Figure A-3: Wired Thermostat Wiring

! NOTE !

Close attention must be paid to the 4 connections for Voltage, Ground and Polarity. Ensure they match to corresponding wires from touchscreen panel

A.3 THERMOSTAT PANEL

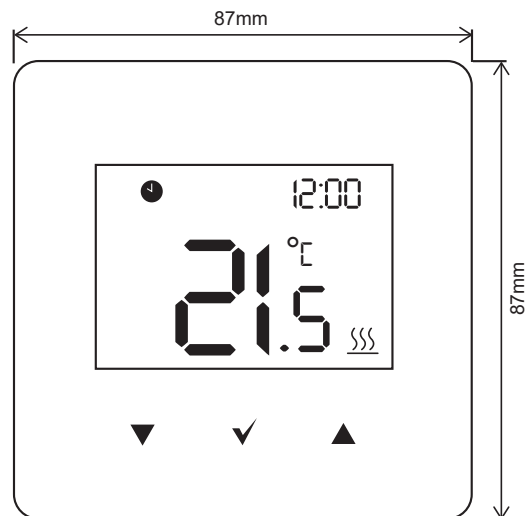











Figure A-4: Wired (& Wireless) thermostat panel LCD

Table A-1: Wired (& Wireless) thermostat LCD symbols

Symbol	Symbol description
	Alarm symbol
	Schedule - Thermostat is schedule managed
	Parameter editing
	Heat demand
	Radio signal (Wireless Thermostat only)
	Low battery indicator (Wireless Thermostat only)
	Decrease parameter
	Confirm
	Increase parameter

A.4 PAIRING

The wired thermostat should be connected as part of the Smart Controller configuration creator for the circuit that the thermostat will measure. To pair again you can follow this within the individual circuit settings to re-pair to the Grant Aeron Smart controller.

- Access the circuit you wish to pair with a wired thermostat panel from the Circuit settings within the System settings menu (Refer to Section 8) and select the Thermostat option from the menu and confirm you wish to overwrite if a thermostat is already present on the circuit.
- The pairing wizard will begin and will instruct you to set put the desired wired thermostat into pairing mode.
- Follow the on-screen prompts. Hold the up and down buttons simultaneously for 2 seconds. The screen will change to display you have entered the user menu where you then select parameter '03' in the user menu of the thermostat. 'PAR' will be displayed on the screen. When confirmed with the '✓' button, the pairing function will start (the word 'PAR' begins to flash).
- Tap '>' on the touchscreen display.
- Confirmation of the pairing will be confirmed by the message 'END' and 'Succ' on the thermostat.
- After pairing a room thermostat holding the '✓' down will return you first to the previous menu and then the back to the main screen in 2 second intervals.

A.5 CHANGING SETPOINT TEMPERATURE

Tapping the up or down arrows will prompt the thermostat into the check/editing of target temperature causing the current target saved temperature to flash.

The first tap of the arrow will trigger the edit temperature function but will not change the value. Tapping the arrow again will then change the value either up or down. Tapping the '✓' will confirm, save and exit.

Not confirming a new target with 5 seconds of inactivity will cause the thermostat to exit the editing mode without changing the target temperature.

! NOTE !

Holding the up or down arrows for more than 2 seconds will cause a fast change to the parameter.

A.6 USER MENU

The user menu is entered by holding simultaneously the and buttons for 2 seconds. Individual parameters of the user menu are visible as consecutive indications displayed on the main screen as described in the table below.

Depending on the controller series, some operating modes and parameters in the user menu may not be visible and some options not applicable to the Aeron Smart Controller as indicated in table below.

The parameters are selected using the up or down buttons and the tick button is confirmed by the selection.

Table A-2: Thermostat menu

Code	Alert description
P01-P02	Not used/Reserved
P03	Pairing
P04-P14	Not used/Reserved
P15	Activate/Deactivate Key sounds.
P16	Activate/Deactivate Alarm sounding. <i>Turning OFF will only display alarm symbol on LCD screen.</i>
P17	Activate/Deactivate Alarm sounding OFF between 22.00 and 06.00.
P18	Adjust Screen contrast. (%)
P19	Adjust LCD screen backlight. (%)
P20	Not used/Reserved
P21	Activate/Deactivate parental lock.
P31	Thermostat program version.
P32	Thermostat temperature correction (°C)
P34	Restore factory settings
P35	Thermostat address.
P40	Activate/Deactivate Fuel level indicator
P41	Activate/Deactivate outdoor temperature indication.
P42	Show/Hide display on clock screen.
P50	Temperature floor sensor

A.7 ERROR CODES

The Smart controller communicates alerts to the thermostat when present in the system. Refer to Table A-3 for determining the fault of a wired thermostat display.

Table A-3: Thermostat alarm codes

Code	Alert description
01	No communication with the controller
02	No compatibility of programs
03	Panel temperature sensor error
04	DHW sensor error
05	Upper buffer temperature sensor error
06	Lower buffer temperature sensor error
07	Circuit 2 temperature sensor error
08	Circuit 3 temperature sensor error
09	Anti-freeze active
11	No communication with the thermostat
12	No communication with thermostat circuit 1
13	No communication with thermostat circuit 2
14	No communication with thermostat circuit 3
15	Alarm from digital input
16	No flow detected
17	Too often no flow detected
19	No communication with heat pump module
20	Circuit 4 temperature sensor error (not used)
21	Circuit 5 temperature sensor error (not used)
22	Circuit 6 temperature sensor error (not used)
23	Circuit 7 temperature sensor error (not used)
24	No communication with thermostat circuit 4 (not used)
25	No communication with thermostat circuit 5 (not used)
26	No communication with thermostat circuit 6 (not used)
27	No communication with thermostat circuit 7 (not used)

A.8 TECHNICAL DATA

Table A-4: Wired Thermostat Technical Data

Technical Data - Wired Thermostat	
Power supply	5 to 12 VDC, 0.2W directly from the main controller socket, power source max. 15W
Degree of protection	IP 20
Relative humidity	5% to 85% without steam condensation
Storage temperature	-10 °C to +60 °C
Working temperature	0 °C - 40 °C
Display	LCD with backlight
Controlling	Capacitive buttons
Dimensions	87 mm x 87 mm x 27.3 mm
Weight	0.2 kg
The thermostat installation method	ON the wall or free-standing
The radio module installation method	On the wall

Appendix B - Wireless Thermostat and Receiver

B.1 GENERAL

The Grant Wireless receiver & thermostat are designed to provide wireless circuit control via the Grant Aerona Smart controller.

The thermostat should be installed in a suitable location to monitor the circuit, e.g., First floor hallway, and is designed to maintain a target temperature. By sending a radio signal to the module connected to the wireless receiver.

The thermostat on the backlit LCD display shows information about the circuit temperature value, selected operating mode, current time with simultaneous clock synchronization with the touchscreen display.

B.2 INSTALLING WIRELESS RECEIVER

The wireless receiver should be mounted on a wall near the installation location of the wiring centre. If the radio connection is poor, try placing the wireless receiver in other places. Moving the wireless receiver even by a few centimetres can affect the quality of the connection.

! NOTE !

Placing a wireless receiver in a metal casing, e.g. a mounting box, a metal boiler casing, etc. will block the radio signal and thus interfere with the operation.

The radio module should be screwed to the wall with the provided fixings. Access to holes for screws is obtained after unscrewing the cover of this module. Refer to Figure B.1.

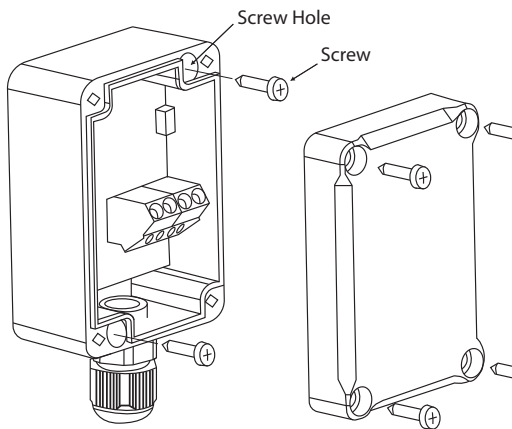

Figure B-1: Wireless receiver wall fixings

Terminals D +, D-, GND, 12VDC of the Wireless receiver should be connected to the G1 socket of the wiring centre.

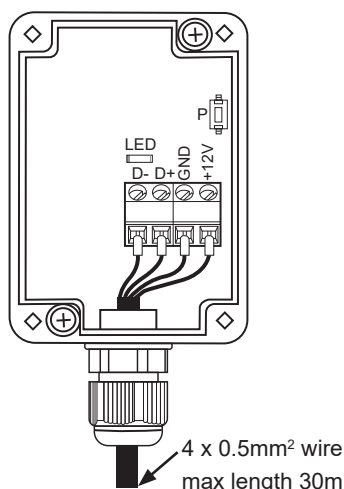

Figure B-2: Wireless receiver wiring

! NOTE !

Ensure the correct polarity of the connection of the D+, D- signals and the GND, +12V power supply between the thermostat and the wiring centre. Incorrect connection may lead to damage to the main controller or errors in its operation.

The maximum cable length depends on the cross-section of the wires. For a 0.5 mm² wire, it should not exceed 30m. The cross-section should not, however be less than 0.5 mm².

B.3 WIRELESS THERMOSTAT

The wireless thermostat is intended for installation only in a dry habitable location and should be placed on a flat surface (as a free-standing device) in a room representative for a given heating circuit. After choosing the place of installation, make sure that:

- The selected location is free of excessive humidity and the ambient temperature of the thermostat should be within the range of 5..35°C.
- The chosen location should ensure free air circulation and should be located away from heat-emitting sources, e.g., electronic equipment, fireplace, heater and direct sunlight.
- The selected place must not cause interference or a lack of radio signal.
- The wireless thermostat panel is operated in the same manner as the wired thermostat. Refer to Section A.5 for details on adjusting temperature setpoint values.

B.3.1 INSERTING OR REPLACING THE BATTERIES

To insert or replace the battery, remove the back cover of the thermostat housing.

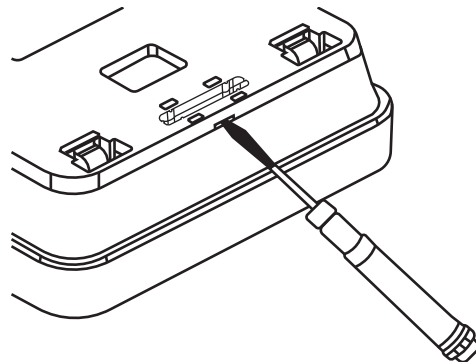

Figure B-3: Wireless Thermostat back access

When inserting the batteries, the battery poles have to be positioned correctly. Check thermostat moulding for guidance.

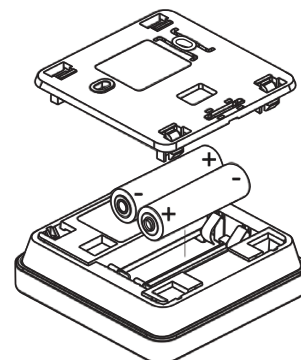

Figure B-4: Battery placement

It is recommended to use alkaline batteries to power the thermostat. The thermostat working time depends on the quality of the batteries used. Refer to Appendix A, Figure A-4 and Table A-1 for low battery indicator symbol.

B.3.2 PAIRING A WIRELESS THERMOSTAT WITH THE WIRELESS RECEIVER

A wireless thermostat will need to be paired with the wireless receiver connected to the wiring centre. Follow the steps to access the individual circuit controls and begin the pairing wizard or follow the steps when using the system configuration creator. Refer to Section A.4.

- If multiple wireless thermostats are required, the radio address for a second or third will need to be changed prior to pairing to avoid pairing conflicts. Refer to Appendix B.4 for multiple thermostat support.
- Pair all required wireless thermostats in the 1st circuit pairing during system configuration or access the circuit settings of an installed circuit after the system configuration has been completed to save the thermostats to the wireless receiver memory. Refer to Section 6 for System configuration creator & Section 7.3 for heating circuit settings.
- The pairing process for the wireless thermostats is similar to the wired thermostat. Refer to Section A.4.
- After all thermostats are paired, return them to their respective home screen by holding the '✓' button down for 4 seconds.
- With multiple wireless thermostats paired, you will be given a choice based on the address of the thermostats saved to the memory of the wireless receiver. Select the thermostat you wish to assign to a specific circuit from the displayed list on the touchscreen display.
- For a second or third circuit, confirm already paired thermostats when prompted to pair to access wireless receiver memory for saved thermostat list.

! NOTE !

Allow up to 1 minute for connection of thermostats and circuit amends to take effect.

! NOTE !

Until the pairing with the wireless receiver is complete, the alarm and radio symbols are permanently displayed on the thermostat screen.

The structural elements of the building, the layout and equipment of rooms, the amount of electronic equipment, the distance between the wireless receiver and the thermostat all affect the quality of the radio signal.

Therefore when choosing a place to install the thermostat, take into account the obtained signal level in the selected location by observing the symbol on thermostat screen. If the symbol:

- is not displayed - Connection has been established
The symbol is shown only briefly during active radio communication with the wireless receiver.
- flashing - There is no connection or there is a weak signal and you should choose a different place to install the thermostat or add a signal repeater.

! NOTE !

The value of the radio signal strength can be read in parameter '30' of the thermostat user menu.

If the radio connection to the thermostat is lost, the Smart Controller will go into an operating mode without a thermostat after a few minutes.

After establishing the radio connection with the thermostat in the touchscreen display Information menu in the Software versions tab, the thermostats will be shown as a Wireless thermostat, with the version of the software displayed.

Connecting the wireless receiver to the wiring centre again does not require pairing if the thermostats have previously been paired.

B.4 MULTIPLE THERMOSTAT SUPPORT

The wireless receiver can manage up to 3 wireless thermostats. Utilising multiple thermostats with the wireless receiver will require setting an individual address for each thermostat to avoid conflicts in the heating circuits they are assigned to and must be done prior to assigning to a circuit.

To amend the address of an individual thermostat:

1. Hold the up and down buttons simultaneously for 2 seconds. The screen will change to display you have entered the user menu where you then select parameter '35'. The screen will display the currently assigned address ("Ad1" is the default assigned address).
2. Press the '✓'. The current address will flash with the parameter editing symbol. Press Up or down to amend the address and confirm with the tick.
3. Holding the '✓' button down will move you back through the user menu to the home screen.

Follow the pairing procedure for a heating circuit as per Section B.3.2 or the on-screen prompts when configuring a circuit. If successful, when you attempt to assign a wireless thermostat to a new circuit, multiple thermostats will be available to choose.

B.5 THERMOSTAT PANEL

Refer to Appendix A.3 for thermostat panel information.

B.6 USER MENU

The user menu is entered by holding simultaneously the up and down arrow buttons for 2 seconds. Individual parameters of the user menu are visible as consecutive indications displayed on the main screen as described in the table below.

Depending on the controller series, some operating modes and parameters in the user menu may not be visible and some options not applicable to the Aerona Smart Controller as indicated in table below.

The parameters are selected using the up or down buttons and the '✓' button is confirmed by the selection.

Table B-1: Thermostat menu

Code	Alert description
P01-P02	Not used/Reserved
P03	Pairing
P04-P13	Not used/Reserved
P15	Activate/Deactivate Key sounds.
P16	Activate/Deactivate Alarm sounding. <i>Turning OFF will only display alarm symbol on LCD screen.</i>
P17	Activate/Deactivate Alarm sounding OFF between 22.00 and 06.00.
P18	Adjust Screen contrast. (%)
P19	Adjust LCD screen backlight. (%)
P20	Not used/Reserved
P21	Activate/Deactivate parental lock.
P30	Display active Radio strength from the receiver. (%)
P31	Thermostat program version.
P32	Thermostat temperature correction (°C)
P34	Restore factory settings
P35	Thermostat address.
P41	Activate/Deactivate outdoor temperature indication.
P42	Show/Hide display on clock screen.

B.7 MEMORY RESET OF THE WIRELESS RECEIVER

To perform a memory reset, hold down the **P** button in the receiver for approximately 8 seconds. The LED will blink after releasing the button confirming the action.

After performing a reset any required thermostats will need to be re-paired.

B.8 ALARMS

The Smart controller communicates alerts to the thermostat when present in the system. Refer to Table B-2 for determining the fault of a wireless thermostat display.

Table B-2: Thermostat alarm codes

Code	Alert description
01	Outside Temperature sensor error
02	No communication with the controller
03	No compatibility of programs
04	Panel temperature sensor error
05	DHW sensor error
06	Upper buffer temperature sensor error
07	Lower buffer temperature sensor error
08	Circuit 2 temperature sensor error
09	Circuit 3 temperature sensor error
11	Anti-freeze active
12	No communication with the thermostat
13	No communication with thermostat circuit 1
14	No communication with thermostat circuit 2
15	No communication with thermostat circuit 3
16	Alarm from digital input
17	No flow detected
19	Too often no flow detected
20	No communication with heat pump module
21	Circuit 4 temperature sensor error (not used)
22	Circuit 5 temperature sensor error (not used)
23	Circuit 6 temperature sensor error (not used)
24	Circuit 7 temperature sensor error (not used)
25	No communication with thermostat circuit 4 (not used)
26	No communication with thermostat circuit 5 (not used)
27	No communication with thermostat circuit 6 (not used)
28	No communication with thermostat circuit 7 (not used)

B.9 TECHNICAL DATA

Table B-3: Wireless Thermostat Technical Data

Grant Aeron Smart Controller - Wiring Centre	
Power supply	2 x AA (LR6) 1.5V - alkaline batteries
Radio module power supply	5 to 12 VDC - directly from the main controller socket
Degree of protection for the thermostat/radio module	IP 20/IP 40
Relative humidity	5 to 85%, without steam condensation
Storage temperature of the thermostat and radio module	-10 °C to 60 °C
Working temperature of the thermostat and radio module	5 °C to 35 °C
Communication	Bi-directional ISM radio communication
The band of radio transmission	ISM 868 MHz, (the band 865 to 868 MHz)
Transmission power of the thermostat and radio module	20 mW (+13dBm)
Radio network topology	One radio module and up to 3 subordinate thermostats
Display	LCD with backlight
Controlling	Capacitive buttons
Dimensions	Thermostat: 87 mm x 97 mm x 27.3 mm Radio module: 70 mm x 50 mm 7.7 mm
Thermostat/radio module weight	0.2 kg/0.16 kg
The thermostat installation method	On the wall or free-standing
The radio module installation method	On the wall

Appendix C - 3-Port Mixer Valve

C.1 GENERAL

If two distinct weather compensation curves are required, the Grant Aerona Smart Controller can control the curve of the lower temperature circuit with the use of a motorised 3-port mixing valve in conjunction with a water temperature sensor.

This 3-port mixing valve consists of two items

- 3-port valve body – refer to section C.2
- 230 V Electric actuator – refer to section C.3

When configuring the system, if a mixing valve is to be used you need to ensure the correct valve opening time. This is the time the actuator will take to move fully from one end of its movement to the other and is used to achieve the required amount of valve movement for mixing. The actuator (HPID123X) has an opening time of 140 seconds.

The mixing valve can be used in any one of FOUR different orientations, depending on the pipework layout being used, as indicated in the four system diagrams below.

Clockwise rotation - Option 1

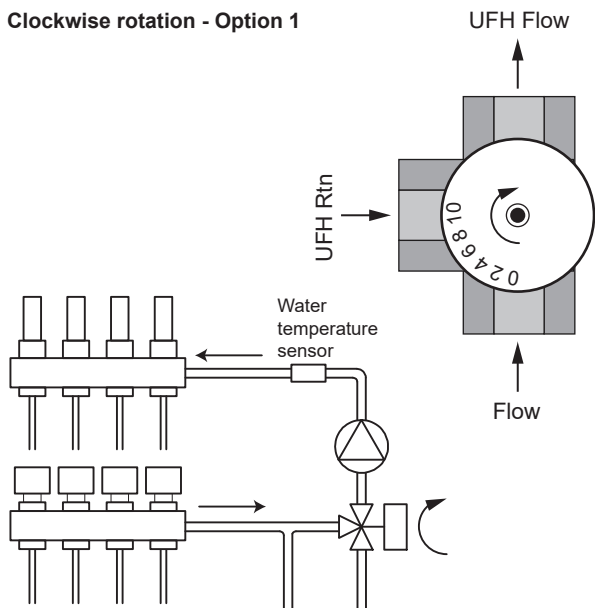

Clockwise rotation - Option 2

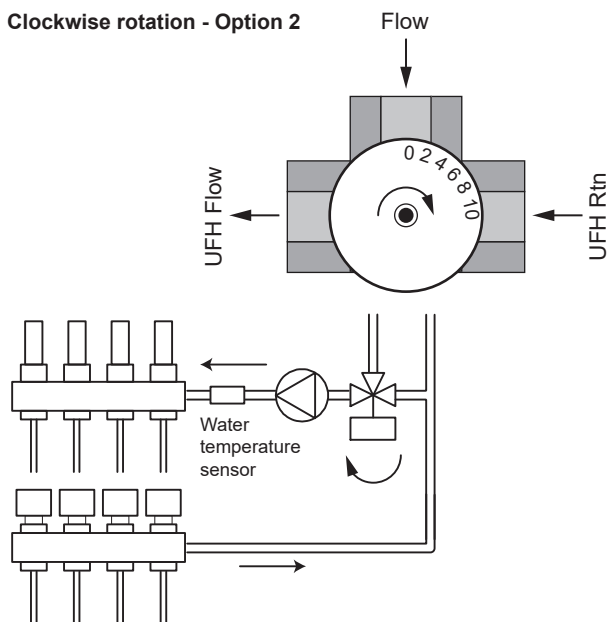
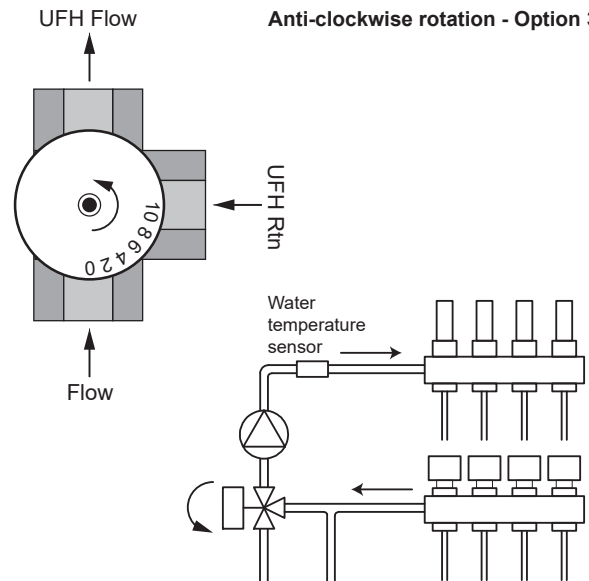

Figure C-1: Clockwise operation valve options

Anti-clockwise rotation - Option 3



Anti-clockwise rotation - Option 4

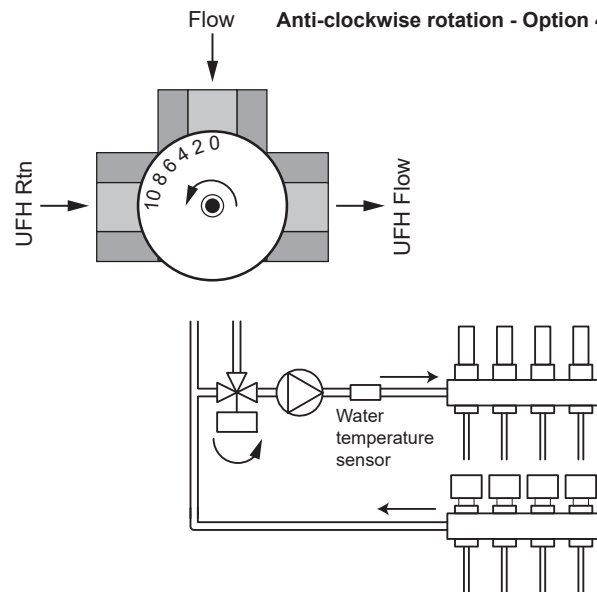

Figure C-2: Anti-clockwise operation valve options

C.2 3-PORT VALVE BODY

C.2.1 VALVE SCALE PLATE

The valve is fitted with a scale plate to identify the position of the valve using either the pointer of the blue handle (supplied fitted to the valve) or the valve drive adapter pointer (marked on the top).

As the valve can be used in any one of FOUR different orientations, depending on the pipework layout being used, the valve scale plate should be correctly positioned for the selected orientation. See Figure C-1 (Clockwise operation) & C-2 (Anti-clockwise operation) for the four different orientations and the required position of the scale plate for each option.

If the position of the scale plate needs to be changed from the factory set position, proceed as follows:

- Unscrew, remove and discard the fixing screw and blue handle supplied attached to the shaft of the 3-port valve.
- Carefully prise the circlip from the valve shaft.

- Lift the scale plate off, and set it in the required position, remembering to flip it over when changing the valve rotation
- Ensure the two cut-outs on the scale plate are fitted on the corresponding lugs on the valve body and then refit the circlip to the valve shaft.

C.2.2 VALVE DRIVE ADAPTER

To fit the valve drive adapter:

- With the blue valve handle already removed, Fit the actuator drive adapter onto the 3-port valve shaft and secure with the countersink screw supplied with the actuator.
- Turn the shaft until the pointer on the valve drive adapter is facing the '0' position on the valve body scale

! NOTE !

Due to the flat on the valve shaft, the drive adapter can only be fitted in one position on the shaft.

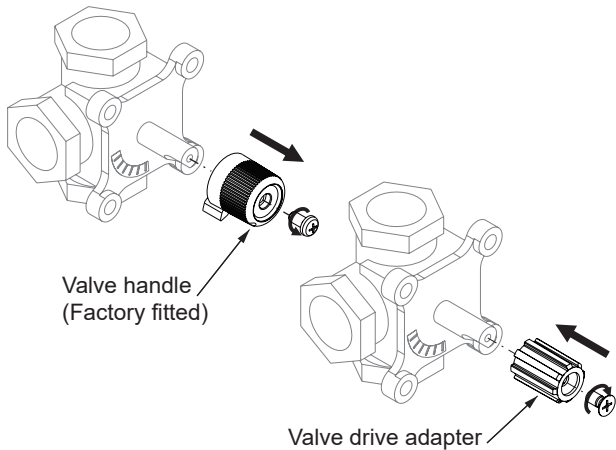

Figure C-3: Fitting the valve drive adapter

C.3 MOTORISED ACTUATOR

C.3.1 INTRODUCTION

The motorised actuator for the 3-port mixing valve is easy to install and provides an indicator for various operational instances, in addition to a easy to use clutch and actuator release buttons.

Refer to Figure C-4 & Table C-1 for key features.

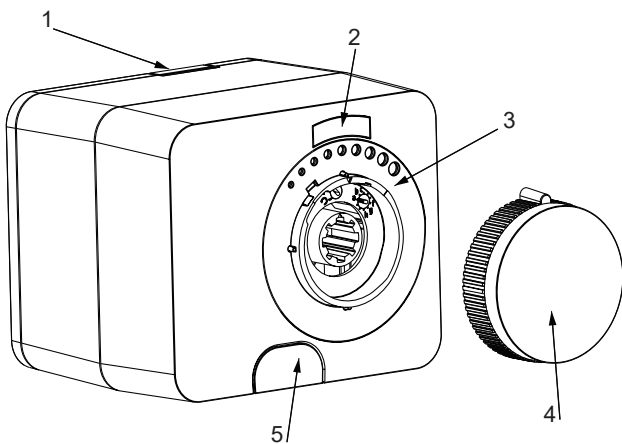

Figure C-4: Motorised actuator

Table C-1: Motorised actuator

Number	Description
1	Mounting release button
2	Operation status indicator
3	Scale plate
4	Manual valve positioning handle
5	Actuator clutch control

C.3.2 OPERATION INDICATOR

The operation status panel provides basic information on motorised actuator when powered. Refer to Table C-2.

Table C-2: Operation status

Symbol	Description
	Rotating Anti-clockwise
	Rotating clockwise
	Actuator clutch released (Manual control)

C.3.3 ACTUATOR SCALE PLATE

The actuator scale plate gives a quick indication of the valve position when it is in operation.

As with the scale plate on the valve body, this must be correctly positioned depending on which of the four different valve orientations is being used, so that the holes increase in size from low to high temperature in the direction of the travel.

If the position of the scale plate on the actuator needs to be changed from the factory set position, proceed as follows:

- Pull off the circular handle from the actuator.
- Place a small flat head screwdriver into the square notch on the inner edge of the scale plate, carefully prise it up and lift away from the actuator housing. Refer to Figure C-5.
- Re-position the scale plate to suit the selected orientation of the valve, remembering to flip it over when changing the valve rotation. Ensure the scale plate is correctly located using the 4 small nibs on the actuator body. Refer to Figure C-5.
- Replace the previously removed handle.

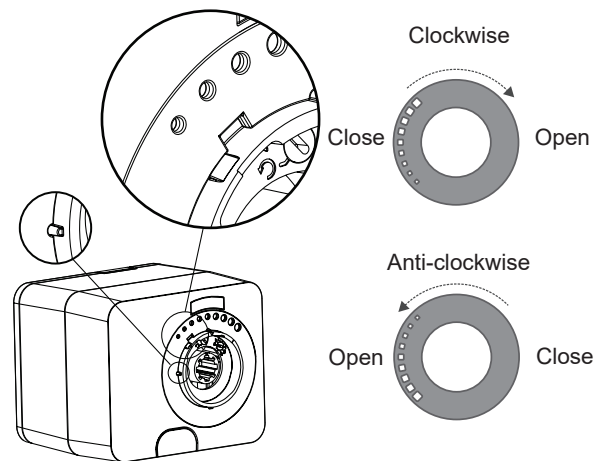

Figure C-5: Actuator scale plate

C.4 ASSEMBLY

To correctly assemble the 3-Port Mixing valve you will need to:

- Ensure the clutch of the motorised actuator is disengaged allowing for free movement with the rotary handle. To disengage, press down on the Actuator clutch control button down until it locks. Refer to Figure C-4 and Table C-1.
- Ensure the actuator scale plate is correctly positioned for the required valve orientation and rotation. Refer to Section C.3.3.

3. Rotate the actuator handle to point to '0' position (smallest hole) on the actuator scale plate.
4. Ensure the valve scale plate is correctly positioned for the required valve orientation and rotation. Refer to Section C.2.1.
5. Fit the drive adapter onto the 3-port valve shaft (refer to Section C.2.2) and ensure the pointer is facing the 0 position on the valve body scale plate.
6. Screw the Anti-rotation peg in place. This can be in any of 3 positions that do not interfere with the power supply cable.

! NOTE !

If the Anti-rotation peg is not fitted the motorised actuator will spin in place and not turn the valve as required.

7. Place the motorised actuator onto the valve aligning the splines on the drive adapter with those in the actuator drive socket. Press and hold the mounting release button and ensure the Anti-rotation peg slots is located into the actuator body. Let go of the mounting release button and the actuator will click into place when correctly attached.
8. Reset the clutch by pressing the Actuator clutch control button allowing it to return to its original position.

C.5 MIXING VALVE WIRING

The motorised actuator is connected via the 2 lives and 1 neutral to the Aerona Smart controller wiring centre, on either H2-M (Circuit 2) or H3-M (Circuit 3). The live connections power the motor in either direction to open or close the valve as required.

Refer to Table C-3 for terminal connections for the Aerona Smart controller wiring centre for Clockwise operation.

Refer to Table C-4 for terminal connections for the Aerona Smart controller wiring centre for Anti-clockwise operation.

Refer to Section 5 Figure 5-3 for wiring centre schematic.

C.5.1 CLOCKWISE OPERATION

The electrical cable supplied with the actuator is connected as follows:

Table C-3: Electrical cable wiring

Description	Wire Colour	Circuit 2 Terminals (H2-M)	Circuit 3 Terminals (H3-M)
230V drive to open the valve	Brown	3	6
230V drive to close the valve	Black	5	8
230V neutral	Blue	4	7

C.5.2 ANTI-CLOCKWISE OPERATION

The electrical cable supplied with the actuator is connected as follows:

Table C-4: Electrical cable wiring

Description	Wire Colour	Circuit 2 Terminals (H2-M)	Circuit 3 Terminals (H3-M)
230V drive to open the valve	Black	3	6
230V drive to close the valve	Brown	5	8
230V neutral	Blue	4	7

C.6 WATER TEMPERATURE SENSOR

The water temperature sensor will measure the mixed flow temperature from the mixing valve and either open or close the valve depending on the required flow temperature for the circuit.

Refer to Section 3.5 for further details on the water temperature sensor and Table C-5 for terminal labels for circuits

Table C-5: Circuit component connections

Heating Circuit	Mixer (Terminals)	Water temperature sensor (Terminals)
2	H2-M (3,4 & 5)	H2-S (39 & 40)
3	H3-M (6, 7 & 8)	H3-S (41 & 42)

! NOTE !

A water temperature sensor must be installed when using the mixing valve to ensure accurate flow into the circuit.

Appendix D - Heating Assistance

D.1 GENERAL

The Anti-Legionella, Supplementary heating and Defrost Assistance functions provide control for an externally connected immersion heater element via the Grant Smart Immersion relay, should they be required.

The Grant Internal 50L volumiser would also require a Grant Smart Immersion Relay to be connected to the Aerona Smart Controller to enable the above functionality.

The Grant External volumiser (Aerona³ only) and Grant Combined volumiser/Low-Loss header have a factory-fitted relay and only need a 230V input to switch the relay. Refer to relevant installation documentation for further information.

D.2 WIRING

Supplementary heater relays are connected to H1 (Terminals 19 and 20) or H2 (Terminals 21 and 22). H1 (Back-up heater) is for use with an immersion heater installed in a volumiser or Low Loss header, while H2 (DHW) is dedicated for the cylinder immersion heater for Anti-Legionella protection. (Refer to Section 5 for electrical schematics).

A power source independent of the Aerona Smart cylinder must be provided for each externally connected immersion element.

D.2.1 DHW CYLINDER IMMERSION HEATER

Connecting the Grant Smart Immersion relay to a DHW immersion heater will provide a legionella protection regime. Refer to Section D.3 for further guidance.

A switch (MCB) is provided to manually override the relay (only to be activated by a competent person). This will allow the cylinder to be heated by the immersion heater only should there be a failure of the heat pump and/or Grant Aerona Smart controller. Refer to Figure D-1 for Dual voltage example with external switch.

D.2.2 SUPPLEMENTARY IMMERSION HEATER

Connecting the Smart controller to a Grant volumiser (Internal or External) or Low Loss header can provide supplementary heating to assist in meeting a space heating demand or provide defrost assistance during a heat pump defrost cycle. Refer to Figure D-1 for additional wiring requirements when connected in conjunction with the factory-fitted cylinder immersion.

D.3 LEGIONELLA PROTECTION

Legionella disinfection should be scheduled in a window that is ideally after a DHW demand and in a setback heating demand period e.g. Overnight. This is to avoid the least amount of loss in the heating circuits.

The Legionella protection cannot be run twice in a week should the schedule be changed within the settings.

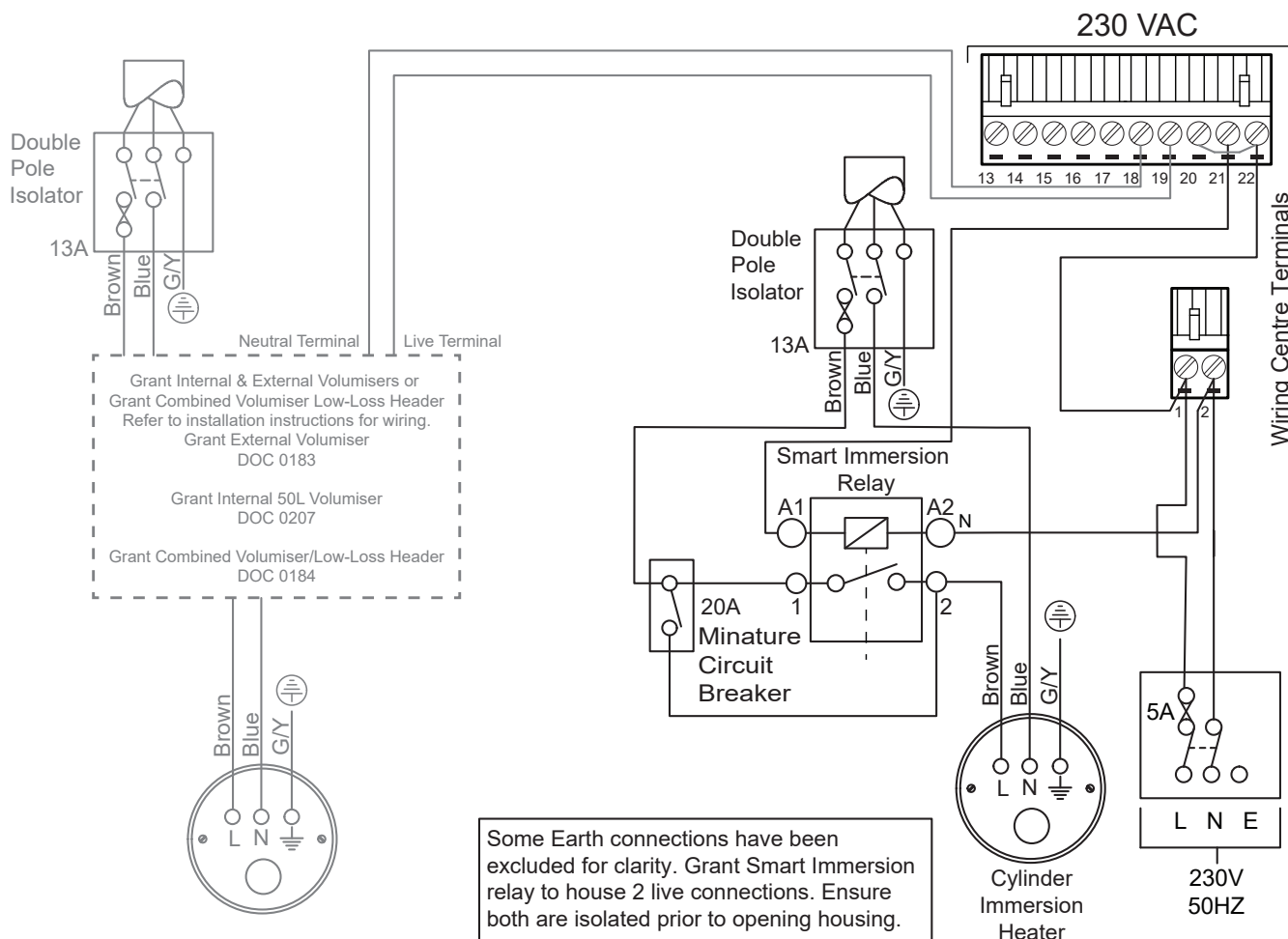

Figure D-1: Supplementary heating examples

D.4 SUPPLEMENTARY HEATING

The controller can be enabled to provide supplementary heating using an immersion heater in a Internal volumiser, External volumiser or Low Loss Header.

The Smart Controller enables the user to configure the time delay for the immersion heater to switch on after a specific demand has begun. Refer to Section 8 - Heaters for the settings of the time delay as well as temperature activation set points should they be required.

D.5 DEFROST ASSISTANCE

The Aeronia Smart controller can aid Grant Aeronia 290 and Grant Aeronia³ heat pumps when the heat pump enters a defrost cycle to provide additional heat into the water side of the plate heat exchanger in the heat pump from a volumiser installed on the return flow to the heat pump.

When entering a defrost cycle, the heat pump will:

- Reverse the refrigerant flow.
- Activate the circulating pump.
- Signal the Aeronia Smart controller that a defrost cycle is active.

The Smart controller will then:

- Activate all configured heating circuits to 'ON' (If not already)
- (If configured) energise H1 (Back-up Heater) to provide assistance to the volumiser.
- (If configured) energise Terminal 46 (Electric Heater) on the Aeronia³ to provide assistance to the volumiser.

The heat from the volumiser as well as the space heating circuits will enter the plate heat exchanger and be transferred to the refrigerant, which is passed into the evaporator coil to thaw any formed ice.

Refer to Section 8 - Heaters for the settings for a Back-up Heater.

For further information on the Grant Internal 50L volumiser and Defrost assistance, Refer to DOC 0207 - Grant UK Internal 50L volumiser.

Appendix E - Smart Flow Sensor

E.1 GENERAL

The Grant Smart Flow sensor is designed to measure the flow rate within the installed system to determine the power output and the coefficient of performance (COP). Over time the function will also show the running SCOP.

E.2 INSTALLATION

Grant UK recommend the Grant Smart Flow sensor should be installed internally on the return to the heat pump after the Grant MagOne magnetic filter.

If an external installation is required, the flow sensor should be protected to prevent exposure to the elements or other external interference.

In order to limit interference to the measurements given to the Aerona Smart controller, we recommend the minimum system pressure to be 1.4 bar to avoid damage from bubble formation and cavitation. You must take all due care to avoid water hammers during both installation and normal operation.

! CAUTION !

The sensor in the measuring tube of the Grant Flow sensor should not be exposed to mechanical loads.

For the optimum measurement accuracy, Smart Flow sensor should be installed as per A in Figure E-1. Vertically with increasing flow allows for the discharge of bubbles upwards and no danger of dirt or sediment deposits within a completely filled pipeline.

Interference from vortices created by bends can occur, so ensure correct distances from elbows are adhered to for calming sections when positioning the smart flow sensor. Refer to Table E-1.

Ensure isolation valves are set in a fully open position and not used control flow.

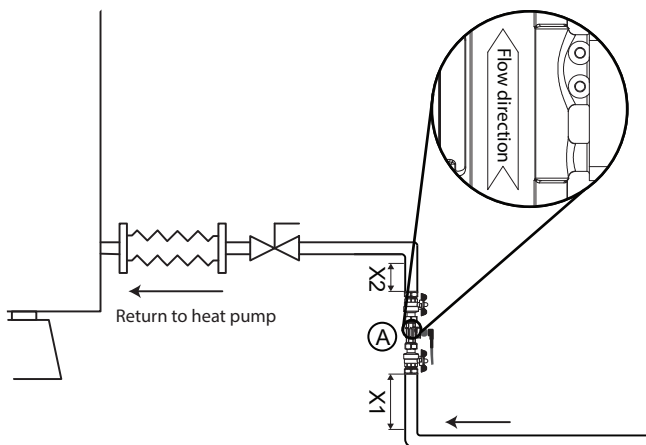

Figure E-1: Smart Flow sensor position A

! NOTE !

Changes in pipe diameter should be treated the same as bends and have suitable calming sections.

Position B (Refer to Figure E-2) would be suitable when installing horizontally. Ensure adequate calming sections before and after the flow sensor to avoid vortices and measurement disturbances. Refer to Table E-1.

Ensure isolation valves are set in a fully open position and not used control flow.

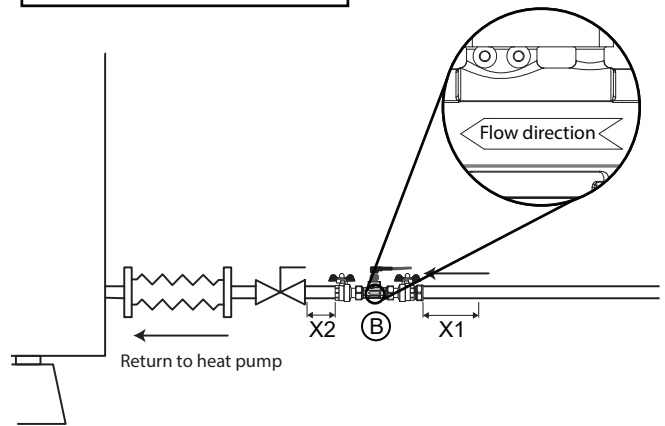

Figure E-2: Smart Flow sensor position B

Position C is unsuitable due to being prior to a point of decreasing flow, misreadings from bubbles formation and possible run empty. Position D would be unsuitable again from being a point of decreasing flow, possible run empty and bubble discharge moving back through the flow sensor.

Refer to Figure E-3 for position C & D.

Ensure isolation valves are set in a fully open position and not used control flow.

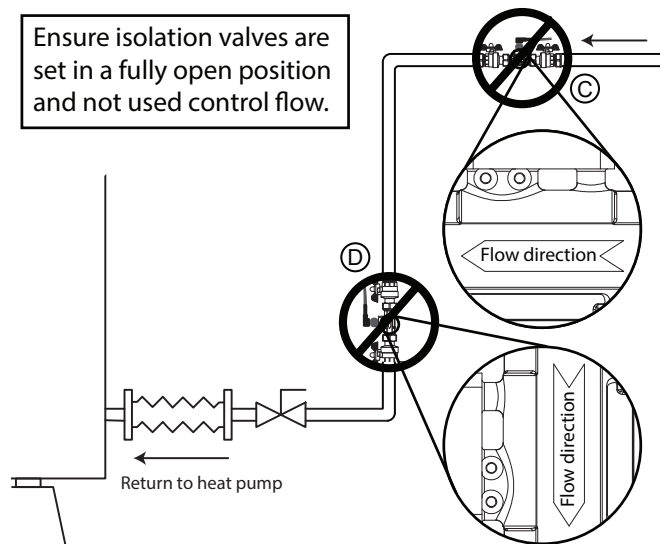

Figure E-3: Smart Flow sensor position C & D

Table E-1: Calming Section measurements

Inlet Section (X1)	Outlet Section (X2)
Minimum 10x DN	Minimum 5 DN

For example, for a pipe diameter of 28mm:

10 x 28mm = 280mm straight pipe before inlet to flow sensor before any bend or fitting

5 x 28mm = 140mm straight pipe after outlet of flow sensor before any bend or fitting.

When a suitable location has been determined:

1. Install suitable pipe fittings.
2. Ensure the flow sensor is correctly positioned as shown by the flow indicator on the outer body.
3. Insert the flow sensor with the O-rings as supplied.
4. Ensure the O-rings are correctly positioned on each end of the flow sensor before fitting the valve union nuts.

! CAUTION !

Avoid over tightening the union nuts and ensure to apply an equal counter force the union nut by using the hexagon of the Smart Flow sensor (Maximum torque of 15Nm). Ensure the electrical connection is pointing upwards or outwards.

E.3 ELECTRICAL

The Grant Smart Flow sensor is supplied with a pre-wired 5 core cable and connector.

- Align the connector with the flow sensor, taking note of the key.
- Insert and secure with the nut. Do not force or overtighten beyond hand tight.

Refer to Table E-2 and Section 5 pack schematics for wiring connections.

Table E-2: Smart Flow sensor wire connections

Wire Colour	Terminal Connection
Brown (Voltage)	+12V (G1 or G4)
White (Not connected)	-
Blue (Ground)	Terminal 32
Black (Signal)	Terminal 31
Grey (Not connected)	-

E.4 SENSOR CONFIGURATION

Once installed, the Aeron Smart controller will need to be configured to use the Smart Flow sensor. You will need to access the flow sensor settings. This is found in service settings (Refer to Section 8).

Table E-3: Smart Flow Sensor configuration settings

Parameter	Value
Flow Meter	Pulse
Specific Heat Capacity	4.180
Time detect(seconds)	120
Time alarm erase(seconds)	30
No flow detection threshold (m ³ /h)	0.1
No flow detection hysteresis (m ³ /h)	0.1
Pulse rate	200
Pulse counting time(seconds)	1
Too often alarm	3

Feature	Function Description	Manual Reference	Set Value
Installer only - Settings for Volumiser's			
Supplementary heating - No defrost support	<p>Low Loss Header</p> <ul style="list-style-type: none"> Check/Configure 'HYDRAULIC SCHEME'. Configure 'ADDITIONAL TEMP SENSOR'. <i>Water Temperature sensor will be required in BB - Refer to Section 4 and 5. If set to 'OFF' the temperature will be measured on the Heat pump return*.</i> Configure 'PRESET WATER TEMP' for the Low Loss Header. Configure 'PRESET WATER HYSTERESIS' for Low Loss Header. Configure 'OFF CIRCUITS DURING CHARGING'. <p>If Immersion supplementary heat is required for the Low Loss Header.</p> <ul style="list-style-type: none"> Configure 'BACK-UP HEATER'. Configure 'BACK-UP HEATER DELAY'. Configure 'BACK-UP HEATER OPERATION IN DEFROST'. Configure 'OUTSIDE TEMP TO ACTIVATE THE HEATER'. Configure 'OUTSIDE TEMP FORCE THE HEATER'. <p><i>* The controller will create a demand to the heat pump separate to any space heating demands until the return temperature is as per 'PRESET WATER TEMP' (used as the target flow temperature with no correction).</i></p>	<p>Section 8</p> <p>Section 8 Section 5</p> <p>Section 8 Section 8 Section 7.12.1</p> <p>Section 8 Section 8 Section 8 Section 8 Section 8</p>	<p>Low Loss Header</p> <p>ON</p> <p>ON</p> <p>ON</p> <p>OFF</p>
Defrost Support - No Supplementary heating	<p>50 Litre Internal Volumiser</p> <ul style="list-style-type: none"> Configure 'BACK-UP HEATER'. Configure 'BACK-UP HEATER OPERATION IN DEFROST'. <p><i>* Defrost support will trigger H1 terminals when the heat pump enters Defrost in all hydraulic schemes. If Defrost support is enabled, you can not utilise supplementary heating for space heating demands.</i></p>	<p>Section 8 Section 8</p>	<p>ON ON</p>
Installer only - Settings for all Grant Smart controller installations.			
Flow sensor	Configure the Grant flow sensor. (Aerona ³ R32 only)	Appendix E	
Aerona ³ Frost Protection	Check and adjust Frost protection parameters (Aerona ³ R32 only)	Appendix G	
Heat Pump Schedule	Configure Heat Pump work mode.	Section 7.6	ON
Smart Controller Work mode	Configure the Grant Aerona Smart controller for heating only.	Section 7.3.3	Work Mode: Winter
DHW Heater Support	<p>Configure DHW Heater for Legionella Protection</p> <ul style="list-style-type: none"> DHW Heater DHW Heater (delay)* <p><i>* This DHW Heater (delay) setting is based on central heating demand active at that time.</i></p>	<p>Section 7.4 Section 8</p>	<p>ON 75mins</p>
Installer & end-user - Settings for Grant Smart controller installations.			
Wi-Fi Hub	<p>Connect the Wi-Fi Hub to end user internet connection. (Ethernet/Wi-Fi)</p> <p>End user to register UID with www.econet24.com. <i>(UID to be recorded for remote access & Grant UK registration.)</i></p>	<p>Section 10 Appendix H</p>	
Heating circuit Day Mode temperature	Demonstrate and configure target air temperature for the heating circuit(s) for Day/Occupied times.	<p>Section 7.3.1.2 Section 7.3.1.3</p>	
Heating Circuit Night mode temperature (Setback)	<p>Demonstrate and configure target air temperature for the heating circuit(s) for Night/Unoccupied times.</p> <p><i>Refer to Table 7-4 for suggested subtractive values based on circuit emitters.</i></p>	<p>Section 7.3.1.2 Section 7.3.1.3</p>	
DHW Cylinder temperature	Demonstrate and configure target DHW cylinder temperature.	Section 7.3.2.1	
DHW Secondary Circulation schedule	Demonstrate and configure DHW Secondary Circulation schedule (if installed)	Section 7.5.4	
Heating Circuit schedules	Demonstrate and configure Heating Circuit(s) schedule for Day/Night modes.	Section 7.5	Work mode: Auto
DHW Cylinder schedules	Demonstrate and configure DHW cylinder Schedules as well as 'BOOST'.	Section 7.3.2.2	Work Mode: Auto
Legionella protection	<p>Check/Enable 'DHW HEATER' support.</p> <p>Enable and demonstrate & configure 'DISINFECTION'.</p>	<p>Section 7.4.1 Section 7.4.2</p>	<p>ON Temp: 60°C</p>
Thermostats (If installed)	<p>Demonstrate use to Thermostat panels to amend circuit target temperatures.</p> <p>Demonstrate how to assign/pair Thermostats to individual circuits.</p> <p><i>End user will need to be informed if thermostats are being used as circuit controls and the issues related to removing them.</i></p>	<p>Appendix A & B Section 7.3.1.1</p>	
System Default	<p>Save System default to Grant Smart Controller memory.</p> <p>Demonstrate how to recall a saved system default.</p>	Section 7.10	

Appendix G - Aerona³ (R32)

G.1 GENERAL

The Grant Aerona Smart controller is compatible with both the Grant Aerona 290 and Grant Aerona³ heat pump ranges.

Should it be required, it is also possible to retrofit the Grant Aerona Smart controller to an existing installed Grant Aerona³ air source heat pump, following the guidance provided in Section G.3 and beyond.

G.2 SERIAL NUMBER

Grant Aerona³ R32 heat pumps manufactured on or after the date/serial number given in Table G-1 for that specific model can be retrofitted with the Grant Smart controller, provided the previously supplied Aerona Remote controller remains connected to the heat pump.

The Aerona Remote controller can be removed only if the heat pump control PCB is replaced with the current version. The control PCB is not supplied as part of the Grant Smart controller kit but is available to purchase from Grant Engineering UK Ltd. (Part Code: HPID885765)

All Grant Aerona³ R32 and R410 heat pumps manufactured before the date/serial number given in Table G-1 for that specific model must have the heat pump control PCB replaced with the current version to enable it to be retrofitted with the Grant Aerona Smart controller. In this case, it is not necessary for the Grant Aerona remote controller to remain connected to the heat pump.

Table G-1: Pre February 2024 Serial numbers

Aerona ³ model	Date of manufacture	Serial number
HPID6R32	05/02/2021	6002007
HPID10R32	21/01/2021	6002249
HPID613R32	19/11/2020	6001193
HPID617R32	19/11/2020	6001401

This serial number for the heat pump can be found on the heat pump data label.

The data label is located on the outside of the heat pump casing:

- on the rear of the HPID6 models.
- on the right-hand end of the HPID10, HPID13 and HPID17 models.

G.3 EXISTING CONTROLS

The existing controls will need to be disconnected from terminals 18, 19 and 20 on heat pump terminal PCB and removed as they will no longer be required. Existing space heating and hot water controls (room thermostats, cylinder thermostats, etc.) are also no longer required as these will be replaced during a Smart Controller installation. Refer to Section 3 for required components and Section 5 for Wiring.

All system & heat pump control functions including accessing and setting the heat pump operating parameters, fault codes and real time information, will be provided by the Grant Aerona Smart controller that will be connected to the heat pump via the Modbus connection (terminals 15 and 16) on the heat pump terminal PCB. Refer to Section 3 and 5 of the Smart Controller installation Instructions for further details.

If the previously installed Aerona Remote controller remains connected to the heat pump it effectively acts as an on/off switch for the heat pump and must be set to **ON** (Green LED is illuminated – Refer to figure G-1) for it to operate.

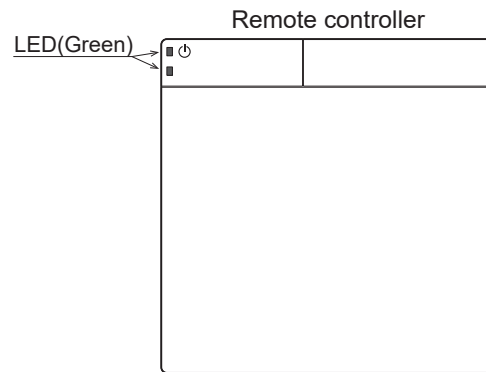

Figure G-1: Aerona Remote controller ON status

G.4 UNDERFLOOR HEATING CONTROLS

If the heating system includes underfloor heating, the underfloor heating controls (room sensors, wiring centres, etc.) will need to be retained if it is intended that they will be used with the controller.

These can be connected to the Smart Controller wiring centre, as required. Refer to the Sections 4 and 5 for further details.

G.5 CONNECTING THE MODBUS

The wiring centre must be connected to the Grant Aerona³ R32 heat pump via the Modbus terminal socket (G2) of the wiring centre to Terminals 15(+) & 16(-) of the Grant Aerona³ R32 heat pump. The shielding should be connected to the RS485 ground (Terminal 32) on the terminal PCB of the heat pump only. Refer to Figure G-2.

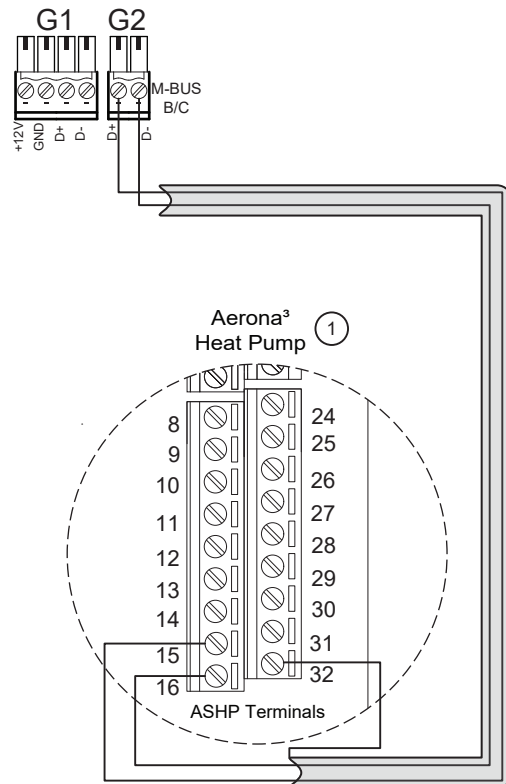

Figure G-2: Modbus Connection

! NOTE !

Shielded, twisted pair cable **MUST** be used for the modbus connection between the wiring centre and Grant Aerona³. Shielded Cat 5/6 is suitable for use.

G.6 AERONA³ FROST PROTECTION

After the system has been configured, check and if needed activate the frost protection within the Heat pump parameters menu via the touchscreen display (Refer to Table G-2).

To access the Heat pump parameters menu:

1. Tap the Settings menu and select 'Service settings' and enter the password: **1234**. Refer to Table 7-1 and Section G.11 for full Aerona³ R32 Heat pump parameters listing.

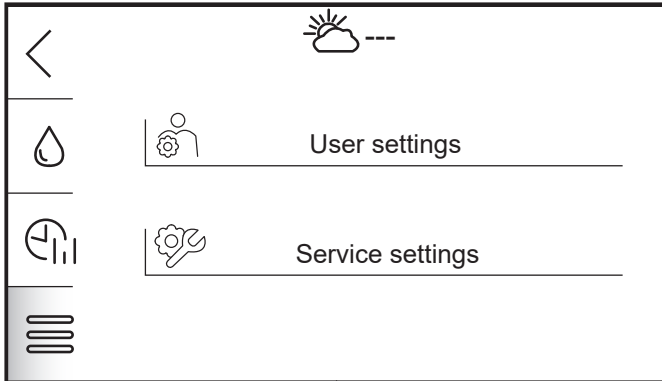

Figure G-3: Settings menu

Table G-2: Frost protection parameters

Parameter No.	Parameter Title	Setting Value
Frost protection		
43 00	Frost Room Temp	ON
43 10	Frost Ambient Temp	ON
43 20	Frost Flow Temp	ON

By default, these should be set as ON on the heat pump. For further information on the frost protect functionality of the Aerona³ heat pump range, refer to your supplied user manual for the Grant Aerona³ heat pump (DOC 0136).

G.7 SERVICE ALARM

In the event of an active 'Service Alarm' being displayed via the Smart controller, refer to Section 11 of the supplied user manual for the Grant Aerona³ heat pump (DOC 0136) for details on how to view the specific error codes via the terminal PCB display and associated other fault finding information.

G.8 SMART IMMERSION RELAY

Grant Aerona³ R32 heat pumps can raise the DHW cylinder to around 50 to 55°C during standard operation.

Using the Smart Immersion relay, the Grant Aerona Smart Controller can enable an installed immersion element to work in tandem with the heat pump to raise the water temperature in a DHW cylinder to a preset temperature.

The Legionella protection function will set a temporary DHW cylinder temperature and then activate the heat pump and immersion element to raise to the water temperature. When the cylinder has reached this temperature, it will stop.

By default, the temperature is 70°C which is sufficient to kill any legionella present.

For more information on the setup of Legionella protection, refer to Section 7.4.

For schematics refer to:

- Section G.9 - System Schematics
- Section G.10 - Wiring Schematics

***For Section G9 continue to page 67.**

G.9 AERONA³ SCHEMATIC - PACK P (SYSTEM)
 Grant UK Drawing Number: HPCS-P001SR32

Item	Description
1	Aerona ³ ASHP
2	Flexible hoses & Isolation Valves ¹
3	Isolation valve
4	Grant Volumiser ^{***} (optional)
5	Anti-Vibration Mounts ²
6	Flow sensor ¹
7	Grant Mag. One magnetic filter kit ²
8	Wiring Centre ¹
9	Touchscreen display ¹
10	Room thermostat
11	Motorized 2-Port valve (DHW)
12	Automatic air vent
13	Cylinder immersion heater
14	Grant QR2 DHW cylinder
15	Immersion heater relay - Optional
16	Drain point
17	Removable filling loop ²
18	Double check valve ²
19	Pressure gauge ²
20	Expansion vessel ¹
21	Tundish
22	Pressure relief valve ²
23	Automatic bypass - Optional ^{**}
24	Thermostatic Radiator valve
25	Motorized 2-Port valve (Radiator circuit)
26	Motorized 2-Port valve (UFH circuit)
27	Thermostatic mixing valve
28	UFH pump
29	UFH manifold
30	Water temperature sensor ¹
31	Outdoor weather sensor ¹

¹ Supplied with the HPIDR32SMART* Smart Controller Kit
² Outputs available: 6, 10, 13 & 17 kW
³ Supplied with the HPIDPACKP
^{**} Refer to installation manuals for further details.

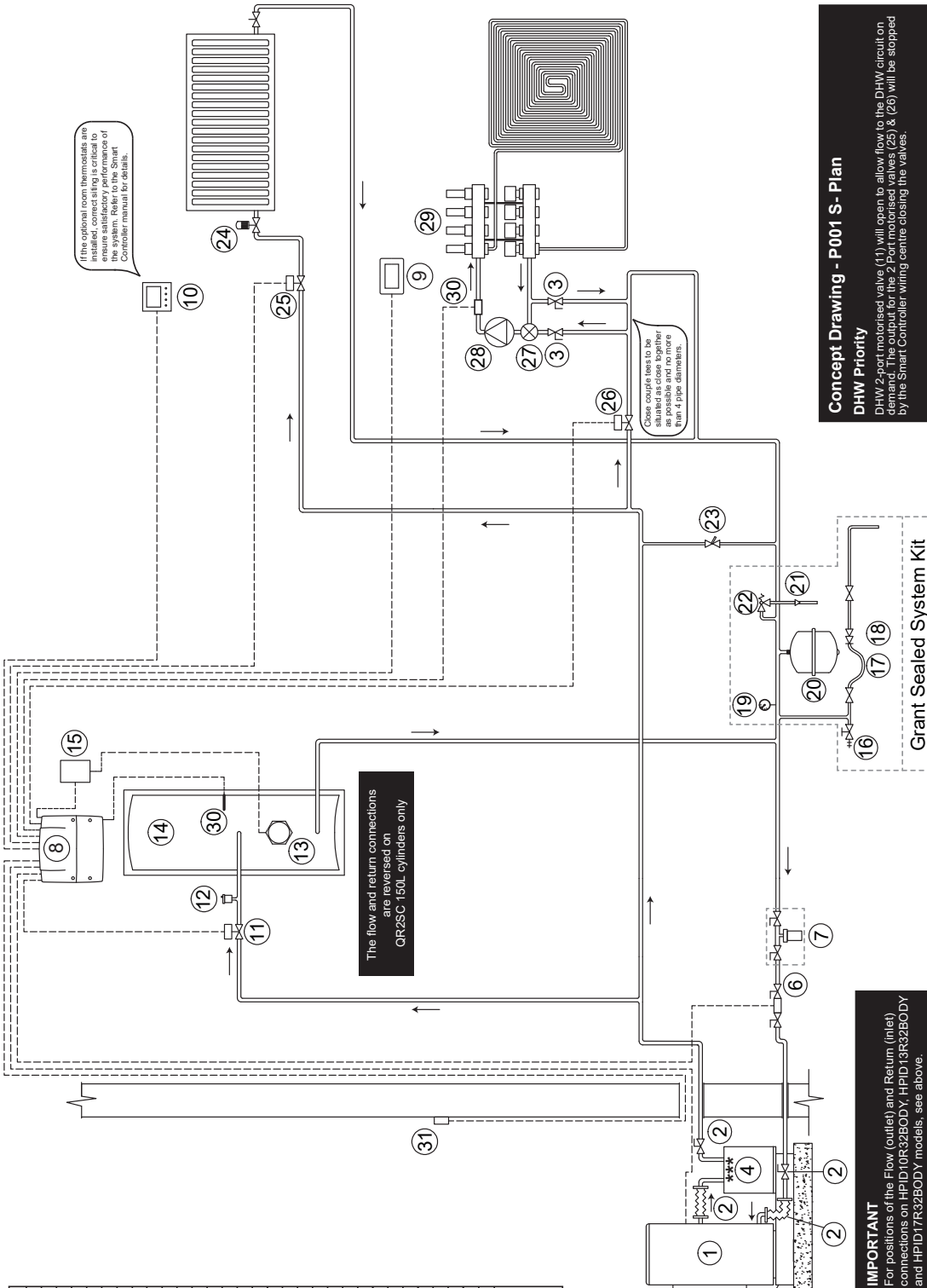

If the optional room thermostat are installed, correct siting is critical to ensure satisfactory performance of the system. Refer to the Smart Controller manual for details.

The flow and return connections are reversed on QR2SC 150L cylinders only

Close couple tees to be used for all connections as far as possible and no more than 4 pipe diameters.

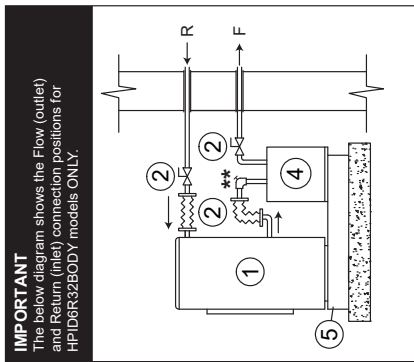

IMPORTANT
 For positions of the Flow (outlet) and Return (inlet) connections on HPID10R32BODY, HPID13R32BODY and HPID17R32BODY models, see above.

! NOTE !
 ***30L external volumiser is available as an optional component where there is insufficient system volume (HPIDVOLEXT30).

! NOTE !
 Please refer to the Aerona³ ASHP installation instructions for details of the flow and return connections at the heat pump.

Concept Drawing - P001 S- Plan
DHW Priority
 DHW 2-port motorised valve (11) will open to allow flow to the DHW circuit on demand. The output for the 2 Port motorised valves (25) & (26) will be stopped by the Smart Controller wiring centre closing the valves.

Circuit 1 - Radiators
 Circuit demand controlled via thermostat (touchscreen or optional wired/wireless). Circuit 2 port motorised valve (25) operation is managed by the Smart controller using 'THERMOSTATIC PUMP/BLOCKADE' function.

Circuit 2 - UFH
 Circuit demand controlled via thermostat (touchscreen or optional wired/wireless). 2 port motorised valve (26) and circulating pump (28) operation is managed by the Smart controller using 'THERMOSTATIC PUMP/BLOCKADE' function. Flow temperature into UFH manifold (29) is managed via the thermostatic mixing valve (27) in case Circuit 1 flow temperature is too high for UFH. No actuators fitted on UFH manifold.

! NOTE !
 For additional heater support from Grant External Volumiser, Refer to Grant/Aerona Smart Controller installation manual and schematics HPCS-BUHS and HPCS-BUHE.

! NOTE !
 This system schematic should be read in conjunction with the Grant Aerona Smart Controller installation instructions and wiring diagram HPCS-P001ER32.

G.10 AERONA³ SCHEMATIC - PACK P (ELECTRICAL)

Grant UK Drawing Number: HPCS-P001ER32

Notes: Some Neutral and Earth connections have been excluded for clarity.

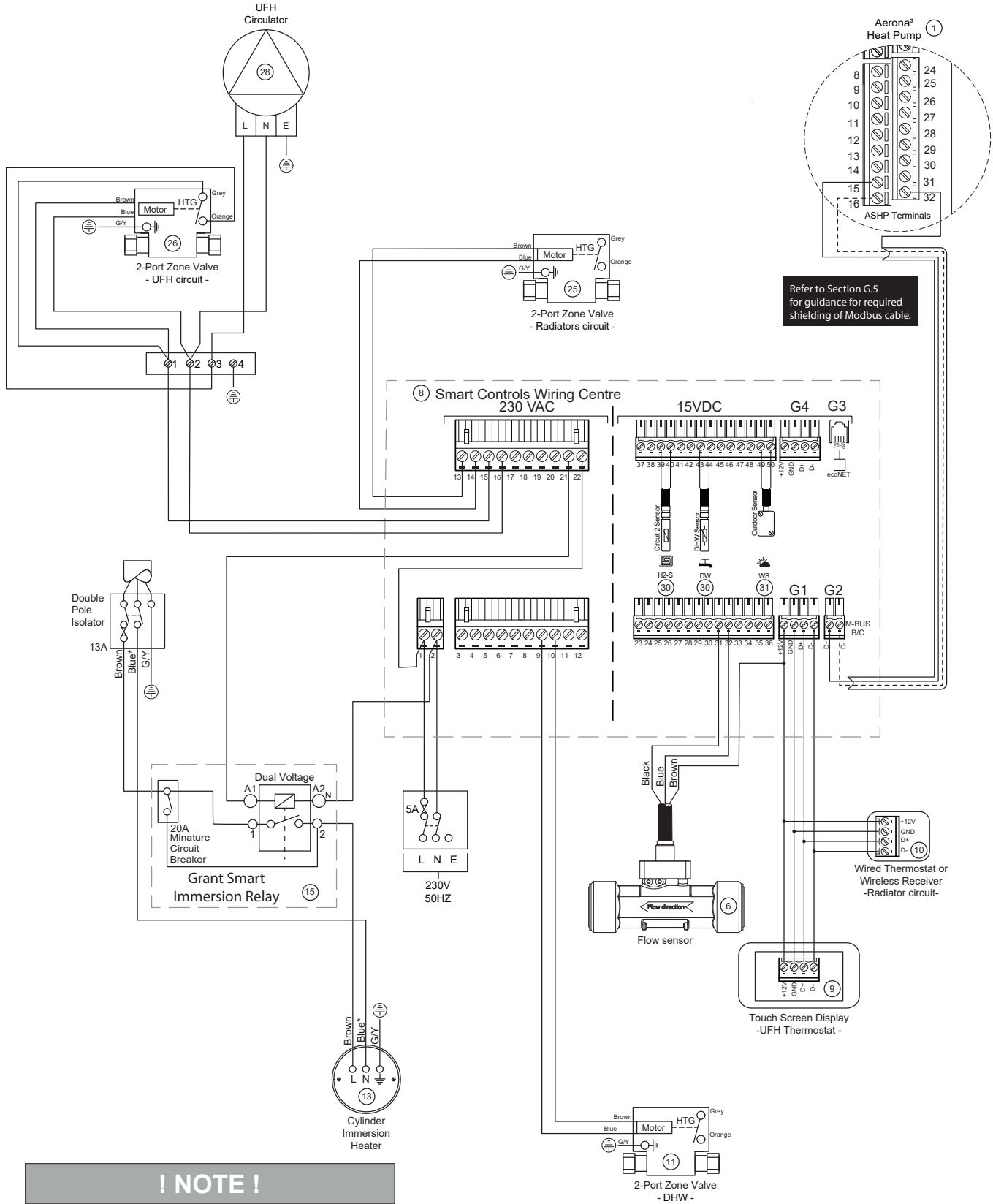

! NOTE !
Cable shielding must be connected to the ground at the heat pump only when connecting the modbus cable.

! NOTE !
*Please ensure that neutrals are derived from the same supply to prevent spurious MCB/RCD trips.

! NOTE !
This wiring diagram should be read in conjunction with the Grant AERONA Smart Controls installation instructions and system schematic HPCS-P001SR32.

G.11 AERONA³ R32 HEAT PUMP PARAMETERS

With the R32 software installed to access the heat pump parameters menu, Tap the Settings menu (Refer to Figure 7-1) and tap 'SERVICE SETTINGS'. Input the relevant password **1234** on the keypad and tap enter.

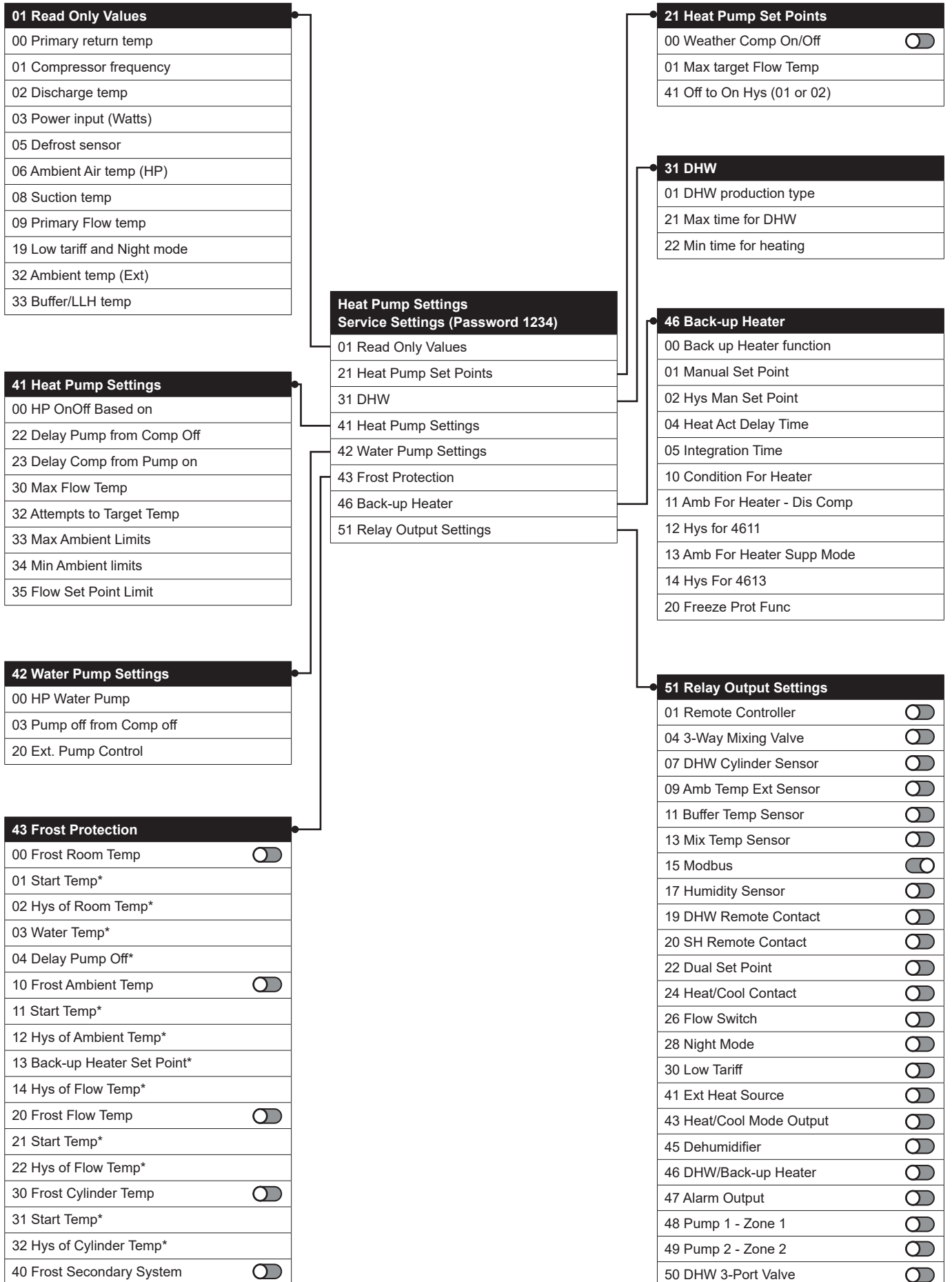

Parameter	Description
01 Read only Values	Heat Pump operating conditions - Displayed information directly from the Heat pump.
21 Heat Pump Set Points	21 00 - Enable/Disable Weather Compensation on Heat Pump (Do not enable) 21 01 - Setting for the Maximum Target Flow temperature (Smart controller adjusts automatically) 21 41 - Hysteresis set point to enable the Heat pump
31 DHW	31 01 - Heat pump priority on DHW demand 31 21 - Max time the Heat pump can run for a DHW demand 31 22 - Minimum time for a Space heating demand
41 Heat Pump Settings	41 00 - Heat Pump control based on selected set point 41 22 - Delay time for Pump off after compressor off 41 23 - Delay time for Compressor on after Pump on 41 30 - Maximum Flow temperature set point for Heating and DHW 41 32 - Set the max number of attempts for Heat pump to reach target temperature 41 33 - Maximum ambient temperature at which the Heat pump will operate 41 34 - Minimum Ambient temperature at which the Heat pump will operate 41 35 - Flow set point limits
42 Water Pump Settings	42 00 - Operation settings of Water pump 42 03 - Delay time of Water pump OFF from Compressor OFF 42 20 - Operation settings for an external secondary Water pump
43 Frost Protection	43 00 - Frost Detection based on room temperature 43 01 - Start Temperature set point for frost protection based on room temperature 43 02 - Hysteresis of room temperature to activate frost protection based on room temperature 43 03 - Temperature set point of circulated water 43 04 - Time delay for water pump to be deactivated on frost protection end 43 10 - Frost detection based on ambient temperature 43 11 - Start temperature for Frost protection on Ambient Temperature 43 12 - Hysteresis of Ambient temperature 43 13 - Temperature Set point for Back-Up Heater 43 14 - Flow Temperature Hysteresis 43 20 - Enable/Disable Frost protection on Outgoing flow temperature 43 21 - Start Temperature for 43 20 43 22 - Hysteresis of 43 20 43 30 - Enable/Disable Frost protection on DHW Cylinder temperature 43 31 - Start temperature for 43 30 43 32 - Hysteresis for 43 30 43 40 - Frost Secondary System - Frost Protection for a slave heat pump connected in cascade.
46 Backup Heater	46 00 - Enable/Disable Back-up Heater 46 01 - Back-up Heater Temperature Set point 46 02 - Hysteresis for 46 01 46 04 - Delay time for Back-up Heater activation 46 05 - Integration time for starting the heater 46 10 - Power condition of Back-up Heater 46 11 - Ambient temperature for enabling Heater & Disable compressor 46 12 - Hysteresis for 46 11 46 13 - Ambient temperature to activate Heater Supplementary mode 46 14 - Hysteresis for 46-13 46 20 - Enable/Disable Freeze Protection Function
51 Relay Output settings	Enable/Disable Heat Pump terminal PCB relays as listed - Refer to Figure 9-1

! NOTE !

*** Dynamic menu items within the menu will change depending on configured system.**

Appendix H - ecoNET

H.1 ECONET24

The ecoNET24 platform provides remote access to the Aerona Smart controller for monitoring and management.

There are two levels of account access:

- **Homeowner** – ability to monitor and control a single installation. A customer's personal data is only visible at this level.
- **Installer** (Service engineer) – ability to monitor and control multiple installations. Each controller UID must be added independently to be visible on this account. Remote monitoring and access is possible if homeowner has set their system to 'PREVIEW' or 'MODIFICATION' mode. Remote monitoring and access will not be possible if homeowner has 'FORBIDDEN' access.

H.1.1 HOMEOWNER ACCOUNT REGISTRATION

The Homeowner account is designed to only monitor a single Aerona Heat Pump installation with a smart controller.

- This account should be set up under the homeowner's email address and can be accessed from either the ecoNET app or web-based portal.
- The homeowner will need to agree to the Terms of Use.

! NOTE !

To use the app you will need to first register via the website at www.econet24.com.

If you are creating a homeowner account for the first time:

- You will need to enter the UID as part of the registration process.
- The ecoNET web-portal will verify the UID is both correct and available to be assigned to an account before the homeowner can enter any further details. Refer to Section H.1.2 on how to obtain the UID from your Grant Aerona Smart controller.

A homeowner with an existing ecoNET account can assign their controller UID to their ecoNET account within the web based ecoNET portal.

- Navigating to the top right corner, selecting the person icon and then 'MY ACCOUNT' from the drop down menu.
- In the left hand menu, select 'MANAGE DEVICES'.
- Enter the UID into the 'ADD CONTROLLER' field and click Submit.

When the account is registered, the Wi-Fi hub will display it is connected with the external server ('Server connection' LED indicator will be active).

H.1.2 HOW TO OBTAIN THE UID

Follow the steps to obtain the UID.

1. When the heating circuit control interface is shown (see Figure 7-1), tap settings menu. Refer to Table 7-1 and Figure H-1.

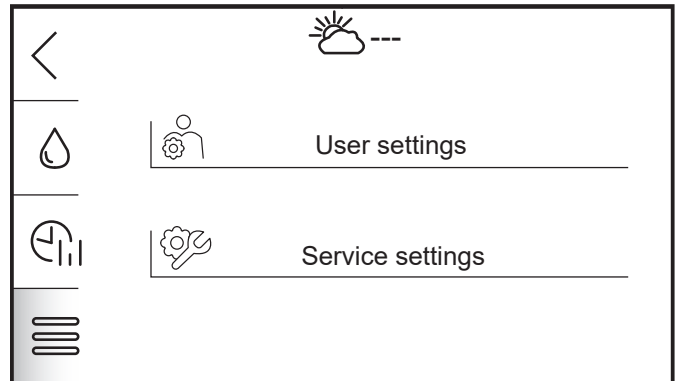

Figure H-1: Settings selection

2. Then tap the User settings. Refer to Figure H-2.

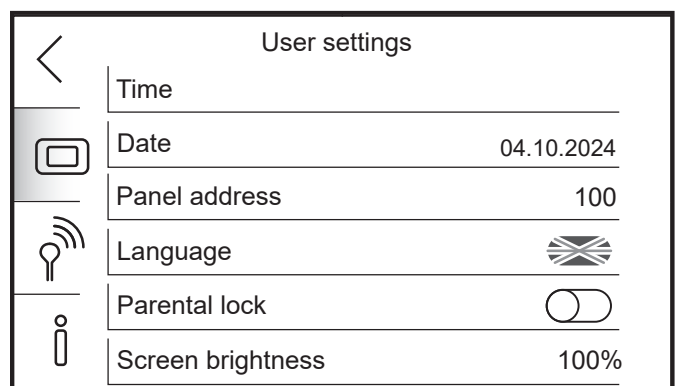

Figure H-2: User settings menu

3. Tap the information icon at the bottom. Refer to Figure H-3.

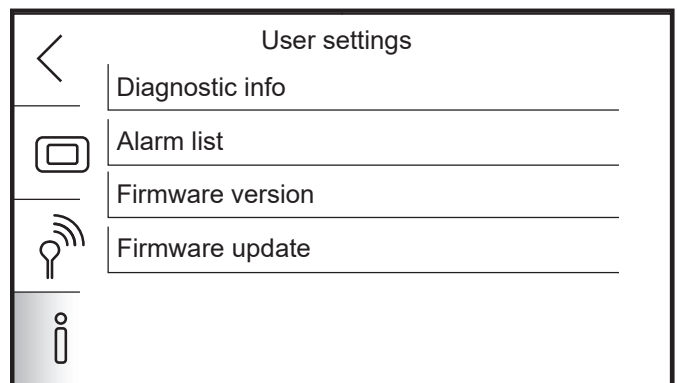

Figure H-3: Controller information options.

4. Then tap 'FIRMWARE VERSION'. Refer to Figure H-4.

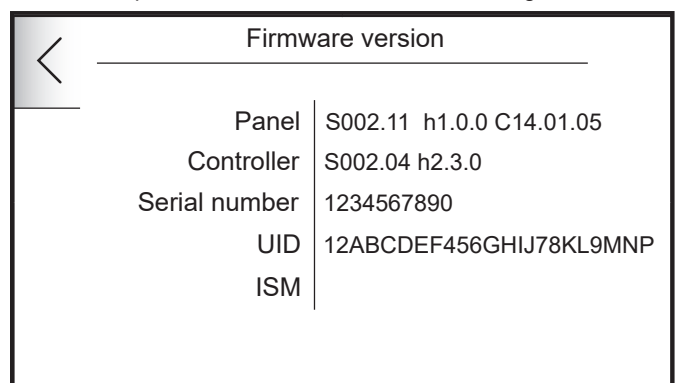

Figure H-4: Firmware version and UID

H.1.3 REMOTE ACCESS MANAGEMENT

Within the ecoNET account via the web-portal, the homeowner can also control remote external access rights to their smart controller installation. This setting applies to all available external access accounts.

- Navigate to 'DEVICE SETTINGS' on the web-portal home screen.
- Locate 'OTHER SETTINGS' at the bottom of the list on screen.
- The label given to the installation will be displayed along with a drop down that will present the 3 options available.
 - **Preview** – Read only access
 - **Modification** – Edit access
 - **Forbidden** – No access

H.1.4 TRANSFER OF OWNERSHIP

If the smart controller is assigned to an account, that account will need to be removed from ecoNET24 to release the UID.

An existing homeowner can remove their account via the web based ecoNET portal.

- Navigating to the top right corner, selecting the 'PERSON ICON' and then 'MY ACCOUNT' from the drop down menu.
- In the left-hand menu, select 'REMOVE ACCOUNT'.
- The remove account page will prompt for the user to enter the current password for the account to.
- After entering the current password click the 'DELETE' button to confirm.

An incoming homeowner without an ecoNET account will need an unassigned UID to start the registration of their ecoNET24 account. (Refer to Section H.1.1).

! NOTE !

A device UID can only be registered to a single ecoNET24 homeowner account.

H.1.5 G1 REMOTE ACCESS ACCOUNT

This account level is available to G1 heat pump installers only and can only be accessed via the ecoNET web-based portal.

G1 heat pump installers can apply for this account level through their G1 Portal.

- In the left-hand navigation menu, click on 'ECONET24 APPLICATION' and complete the form.
- Following submission, this form will be sent to the software provider and a copy to the Pre-Sales Technical Team.
- The Grant Pre-Sales technical team will issue login details including a temporary password to the G1 heat pump installer via email within 48 hours.
- The installer should consider changing their password on their first log in.

We recommend this account be setup in advance of their first (or next) Aeron smart controller installation. This will allow the G1 installer to both check the functionality and demonstrate it for the homeowner.

For the installer to add a controller to their account, the homeowner account must first be registered.

- Navigate to the top right corner, selecting the person icon and then 'MY ACCOUNT' from the drop down menu.
- In the left hand menu, select 'MANAGE DEVICES'.
- Enter the UID into the 'ADD CONTROLLER' field and click Submit.

To allow permission for remote access the homeowner must toggle the remote access rights to be either 'PREVIEW' (read only) or 'MODIFICATION'. Refer to Section H.1.3.

For more information about the G1 Installer Scheme, please visit:

Table H-1: QR Code - G1 Scheme Overview

QR Code	Link
	GrantUK G1 Scheme Overview www.grantuk.com/professional/g1-scheme/

Appendix J - EvoLink Smart

J.1 EVOLINK SMART

The EvoLink Smart is an accessory to the Grant Aerona Smart Controller to utilise both a Grant Aerona Air Source heat pump as the main heat source (MHS) and a additional heat source (AHS) e.g. a boiler to provide heated system water in the most economical way possible.

Refer to UK DOC 0209 - Grant EvoLink Smart Installation and Operating instructions for further information.

J.2 PARAMETERS

To configure the EvoLink Smart you will first need to activate the 'Additional Heat Source' functions of the Aerona Smart controller either by:

- Enabling during the configuration wizard. (Refer to Section 6)
- Enabling from the System settings menu. (Refer to Section 8)

Table J-1: AHS (Boiler) settings menu - Smart Controller

Parameter	Description	Parameter values			
		Default	Min	Max	Unit
AHS Enable	Toggle icon to activate or deactivate AHS (Boiler) support. This will be ON if it was configured during System configuration creator.				
AHS Pump settings	Sub menu for PWM pump control. (Refer to Table 5-2)				
Work in alarms	Allow EvoLink Smart to operate when MHS (Heat Pump) in Alarm state.	N			
MHS below setpoint delta - CH	Temperature below setpoint the MHS (Heat Pump) needs to achieve in setpoint time to activate AHS (Boiler) for space heating demands	3	0	15	°C
MHS below setpoint time - CH	Time value in which MHS (Heat Pump) should reach setpoint delta value for space heating demands upon start to activate AHS (Boiler)	45	0	180	mins
MHS below setpoint time again - CH	Time value counter from first setpoint in which the MHS (Heat Pump) should reach setpoint delta to activate AHS (Boiler)	15	0	180	mins
MHS below setpoint delta - HDW	Temperature below setpoint the MHS (Heat Pump) needs to achieve in setpoint time to activate AHS (Boiler) for DHW demands	3	0	15	°C
MHS below setpoint time - HDW	Time value in which the MHS (Heat Pump) should reach setpoint delta value for DHW demands to activate AHS (Boiler)	10	0	180	mins
MHS stop temp	Toggle icon to enable MHS (Heat Pump) to stop supplying heat at configured temperatures				
MHS stop temp	Temperature value at which the MHS (Heat Pump) stops supplying heat for demands	-5	-30	-4	°C
MHS start temp	Temperature value at which the MHS (Heat Pump) starts supplying heat for demands	-4	-5	5	°C
Stop AHS - pump power threshold	PWM pump speed to start under threshold counter to turn off AHS (Boiler) during a demand for space heating	32	0	100	%
Stop AHS - time under threshold	Time counter for pump power threshold to be under value to turn off AHS (Boiler) during a demand for space heating	20	0	180	mins
Stop MHS - return reached delta	Temperature value of delta between flow and return of the MHS (Heat Pump) to stop MHS (Heat Pump) compressor	2	0	15	°C
MHS pump power when AHS only	MHS PWM pump speed when AHS only	100	0	100	%

Table J-2: AHS (Boiler) Pump settings sub menu - Smart Controller

Parameter	Description	Parameter values			
		Default	Min	Max	Unit
Pump characteristic	Configure pump type for operation H: Heating S: Solar	H			
Startup percentage	PWM startup power.	17	0	100	%
Minimum power	Minimum power setting of PWM pump	17	0	50	%
Maximum power	Maximum power setting of PWM pump	100	0	100	%
Max power step change	PWM power adjustment for temperature adjustments	10	0	50	%
Adjustment time	Time for PWM power step to be adjusted	15	5	300	secs
PID: Kp	PID Controller settings	2			
PID: Ti		160			
PID: Td		30			
AHS-MHS temp difference to start	Temperature delta between AHS (Boiler) flow and MHS (Heat Pump) flow for PWM pump to start mixing.	5	-50	20	°C
AHS-MHS temp difference to stop	Temperature delta between AHS (Boiler) flow and MHS (Heat Pump) flow for PWM pump to stop mixing.	0	-50	20	°C

Table J-1 indicates the main Additional heat source menu options for the operation of the EvoLink Smart in relation to both ambient and MHS temperature conditions for both space heating and hot water demands.

Table J-2 is the sub-menu options specific to the control of the pump fitted in the EvoLink Smart as part of the overall operation of the device.

J.3 OPERATION

The EvoLink Smart is managed by the Aerona Smart Controller to utilise a Grant Aerona heat pump as the main heat source (**MHS**), and an additional heat source (**AHS**) e.g. a boiler, to provide heated system water in the most economical way possible.

Refer to UK DOC0209 Section 5 for further information on commissioning and parameters for the operation of the EvoLink Smart.

! NOTE !

Boiler flow temperatures will not be managed from the Smart Controller and will need to be set manually.

The Smart Controller will also not manage the modulation of the boiler.

J.3.1 SPACE HEATING

- If there is a space heating demand, the Aerona Smart Controller will operate the MHS as designed for the circuit or circuits configured on the smart controller.
- The output flow temperature measured from the system flow pipe is determined by the highest required flow temperature from the configured system. This will include weather compensated or set point temperature and any configured temperature corrections.
- If the MHS is not able to reach the desired flow temperature '**MHS below setpoint delta - CH**' within a period of time '**MHS below setpoint time - CH**' or consecutive '**MHS below setpoint time again - CH**', the Aerona Smart Controller will activate the AHS (boiler) and the boiler flow is circulated through the left hand section of the EvoLink header.
- When the boiler flow temperature on the boiler flow pipe is above the Evolink flow sensor temperature by the configured amount '**AHS-MHS temp difference to start**', the PWM mixing pump will start, pulling the boiler flow into the right hand section of the header and mixing it with the heat pump flow to achieve the required weather compensated flow temperature.
- As the ambient outside temperature falls, and the heat demand on the system increases, the required higher weather compensated flow temperature in the mixing tank is achieved by using a greater amount of the boiler flow until the weather compensated flow temperature is achieved.
- This may be at the maximum flow temperature from the boiler.
- Once started, even when the required weather compensated flow temperature has been achieved, the boiler will remain in operation until either,
 - a) the end of that heating demand, i.e., until the room thermostat or programmer switches off.
 - or
 - b) when the heating load diminishes and deltaT across the system '**Stop MHS - return reached delta**', where it will be automatically switched off.

J.3.2 HOT WATER

- If there is a hot water demand from the Smart Controller, any space heating demands will be cut, causing any valves or pumps associated to space heating to close/stop and valves/pumps associated with DHW supply to open/start.
- The heat pump operates to achieve the calculated flow temperature to the DHW cylinder. This will be calculated based on configured cylinder set point and any additional temperature corrections.
- If the MHS is not able to reach the desired flow temperature '**MHS below setpoint delta - HDW**' within a period of time '**MHS below setpoint time - HDW**' or consecutive '**MHS below setpoint time again - HDW**', the Aerona Smart Controller will activate the AHS (boiler) and the boiler flow is circulated through the left hand section of the EvoLink header.
- When the boiler flow temperature on the boiler flow pipe is above the Evolink flow sensor temperature by the configured amount '**AHS-MHS temp difference to start**', the PWM mixing pump will start, pulling the boiler flow into the right hand section of the header and mixing it with the heat pump flow to achieve the required weather compensated flow temperature.

- As the ambient outside temperature falls, and the heat demand on the system increases, the required higher flow temperature in the mixing tank is achieved by using a greater amount of the boiler flow until the temperature is achieved.
- This may be at the maximum flow temperature from the boiler.
- Once started, even when the required flow temperature has been achieved, the boiler will remain in operation until either,
 - a) the end of that DHW demand, i.e., controller ends demand.
 - or
 - b) when the heating load diminishes and deltaT across the system '**Stop MHS - return reached delta**', where it will be automatically switched off.

J.3.3 BOILER ONLY (SPACE HEATING & DHW)

- When there is a Space heating or DHW demand and the outside air temperature is below or falls to below the '**MHS stop temp**' setting, the boiler will be automatically started and become the 'lead' heat source. The MHS circulating pump will be activated by the Aerona Smart Controller but the compressor and fans will not operate as it will be inefficient for it to do so at this low outside air temperature.
- If the outside temperature rises to above the '**MHS start temp**' setting, the boiler, and the EvoLink circulating pump, will be automatically switched off and the heat pump will start up as lead heat source.
- Should the occupier feel the system is not performing sufficiently for their own comfort, the '**MHS stop temp**' can be adjusted to initiate the boiler only function at a higher ambient temperature (default: -5°C). The '**MHS start temp**' will need to be adjusted accordingly to ensure no conflict in parameters.

J.4 ADJUSTING THE EVOLINK SMART

The default settings for the EvoLink Smart (Refer to Table J-1 & J-2) have been created as a base to operate the heat pump (**MHS**) and boiler (**AHS**) in an efficient manner.

Prior to adjusting any of the settings, it is advised to contact Grant UK for further guidance as any adjustments made from these default settings may lead to increased costs from energy used.

- **MHS Stop temp:** Adjust the temperature where the AHS becomes the only heat source. Ensure the '**MHS Start temp**' is also adjusted accordingly to avoid conflicts.
- **MHS below setpoint delta - CH/HDW:** Adjust the temperature delta value that the heat pump needs to meet the target flow demand. An increase will enable the boiler sooner.
- **MHS below setpoint time - CH/HDW:** Adjust the time in which the heat pump needs to meet the target flow demand before the boiler is activated. A decrease will enable the boiler sooner.

J.5 HEAT PUMP (MHS) OVERRIDE

The Grant EvoLink Smart Control system has the ability to operate the boiler only, without the heat pump to:

- allow the boiler to be serviced or repaired.
- allow the operation of the boiler only to be used at times deemed uneconomical for the heat pump.

The boiler will respond to system demands from the Smart Controller as the only available heat source. For example, when servicing the boiler, the thermostats can be increased to create the demand and in turn activate the boiler.

Refer to Section 7.6 of this manual and Uk DOC 0209 - Grant EvoLink Smart Installation and Operating instructions for further details.

Online Resources

AERONA SMART CONTROLLER - HOW TO PLAYLIST

QR CODE	Description
	<p>How to video guides playlist for the Grant Aerona Smart Controller.</p> <p>The playlist offers a number of helpful guides on how to set individual elements of the Grant Aerona Smart controller and is monitored and updated to ensure the best possible assistance is available.</p> <p>Can't find something specific? Email info@grantuk.com or contact your local sales representative for further assistance.</p>

SCHEMATICS

QR CODE	Description
	<p>Grant UK online portal for approved schematic drawings.</p> <p>The schematics provided give a generalised idea on how to hydraulically and electrically design an installation using the Grant Aerona Smart controller.</p> <p>For further information or queries please contact info@grantuk.com or your local sales representative.</p>

HEAT PUMP ORDERING PROCESS

QR CODE	Description
	<p>Grant UK Heat Pump ordering process</p> <p>The Grant UK heat pump ordering process for heat pumps (Aerona3 and Aerona 290 models).</p> <p>For further information or queries please contact info@grantuk.com or your local sales representative.</p>

Notes

Notes

Notes



GRANT ENGINEERING (UK) LIMITED

Frankland Road, Blagrove Industrial Estate, Swindon, Wiltshire, SN5 8YG
Tel: +44 (0)1380 736920 Fax: +44 (0)1380 736991
Email: info@grantuk.com www.grantuk.com