

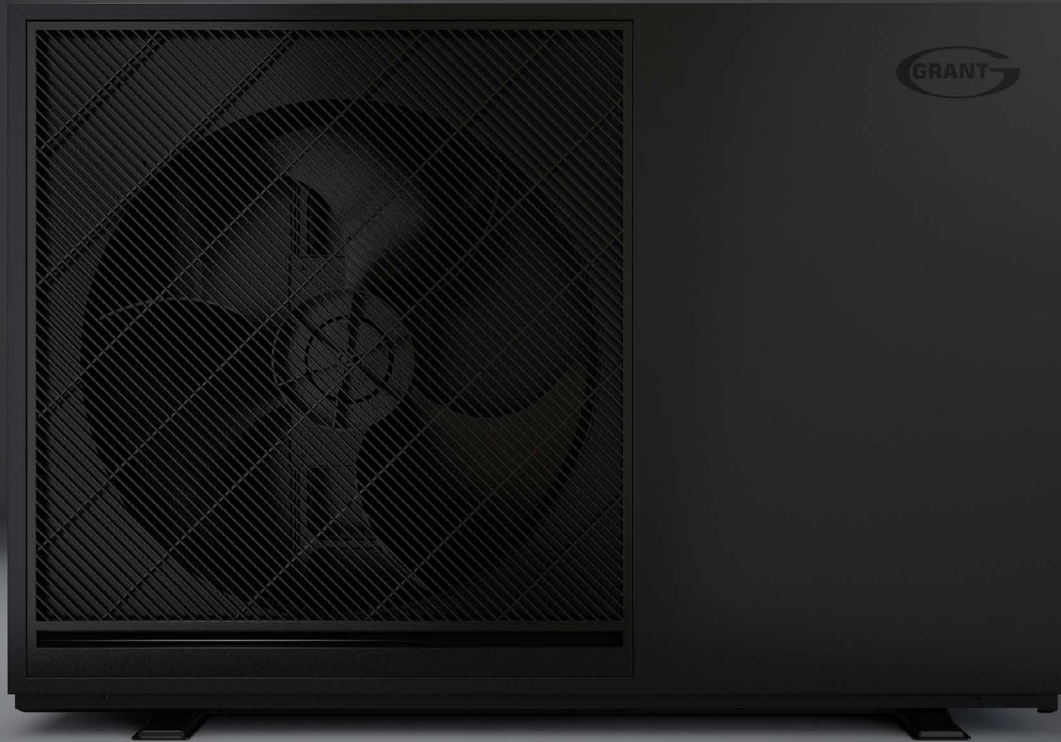

AERONA 290

OUR 5TH GENERATION HEAT PUMP



FOR THE DESIGN

Energy efficient
R290 refrigerant

Ultra low
noise levels

Modern styling
& colourway

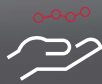

FOR THE PERFORMANCE

Outputs from
4kW - 15.5 kW

Rated at
Air -5°C Water 55°C

Remote monitoring
& management



FOR THE PEACE OF MIND

Performs from
-25°C to + 35°C

7 year
product guarantee*

Design & on-site
technical support

FOR THE NEXT GENERATION



FREE AERONA
290 TRAINING
ENQUIRE HERE

GRANTUK.COM

*T&C's Apply

TECHNICAL DATA

		HPR2904	HPR29065	HPR2909	HPR29012	HPR290155	
VOLTAGE (V)		230	230	230	230	230	
PHASE		1	1	1	1	1	
FREQUENCY (Hz)		50	50	50	50	50	
MAX CURRENT (A)		8.3	12.8	16.8	24.8	29.3	
HEATING CAPACITY	A-5W55 (kW)	4.10	6.76	9.21	12.00	15.57	
COP		2.48	2.27	2.31	2.22	1.9	
BS EN 14511	HEATING CAPACITY	A7W35 (kW)	4.09	7.62	9.38	12.18	16.16
	COP		4.99	4.95	4.93	4.81	4.72
	HEATING CAPACITY	A7W55 (kW)	4.36	7.23	9.30	12.21	16.33
	COP		3.19	3.00	3.11	3.22	2.87
ErP RATING (35°C/55°C) HEATING		A+++/A++	A+++/A++	A+++/A++	A+++/A++	A+++/A++	
RATED AIR FLOW (m³/h)		2300	2650	3350	4050	4050	
PRESSURE DROP (Bar)		0.25	0.39	0.38	0.38	0.40	
REFRIGERANT		R290	R290	R290	R290	R290	
GWP		3	3	3	3	3	
MASS OF R290 REFRIGERANT (kg)		0.61	0.83	1.00	1.20	1.65	
SOUND POWER LEVEL (dB) (BS EN12102-1)		48	52	54	52	53	
QUIET MARK		YES	YES	YES	YES	YES	
SOUND PRESSURE LEVEL (Q=2)	1m db	40	44	46	44	45	
	3m db	31	34	36	34	35	
WATER CONNECTIONS		1" BSP	1" BSP	1" BSP	1" BSP	1" BSP	
WEIGHT (KG)	EMPTY	99	115	131	153	180	
	FULL	102	117	133	157	184	
HEIGHT (mm)		803	854	854	1365	1365	
WIDTH (mm)		1155	1223	1223	1155	1155	
DEPTH (mm)		422	461	461	425	425	
OPERATING AMBIENT TEMPERATURE RANGE SPACE HEATING (°C)		-25 to 35	-25 to 35	-25 to 35	-25 to 35	-25 to 35	
OPERATING AMBIENT TEMPERATURE RANGE HOT WATER (°C)		-25 to 43	-25 to 43	-25 to 43	-25 to 43	-25 to 43	
OPERATING FLOW TEMPERATURE RANGE SPACE HEATING (°C)		25 to 75	25 to 75	25 to 75	25 to 75	25 to 75	
OPERATING FLOW TEMPERATURE RANGE HOT WATER (°C)		20 to 70	20 to 70	20 to 70	20 to 70	20 to 70	
DNO CONNECTION TYPE		C & N	C & N	C & N	C & N	C & N	

DIMENSIONS

4kW

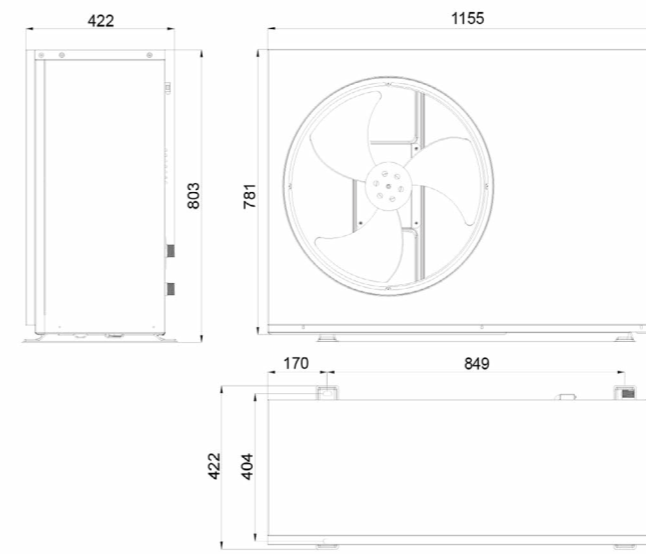

6.5kW & 9kW

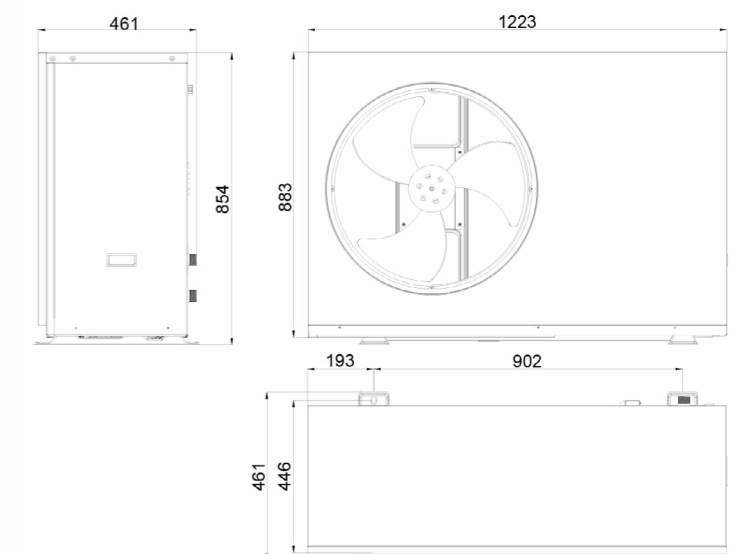

12kW & 15.5kW

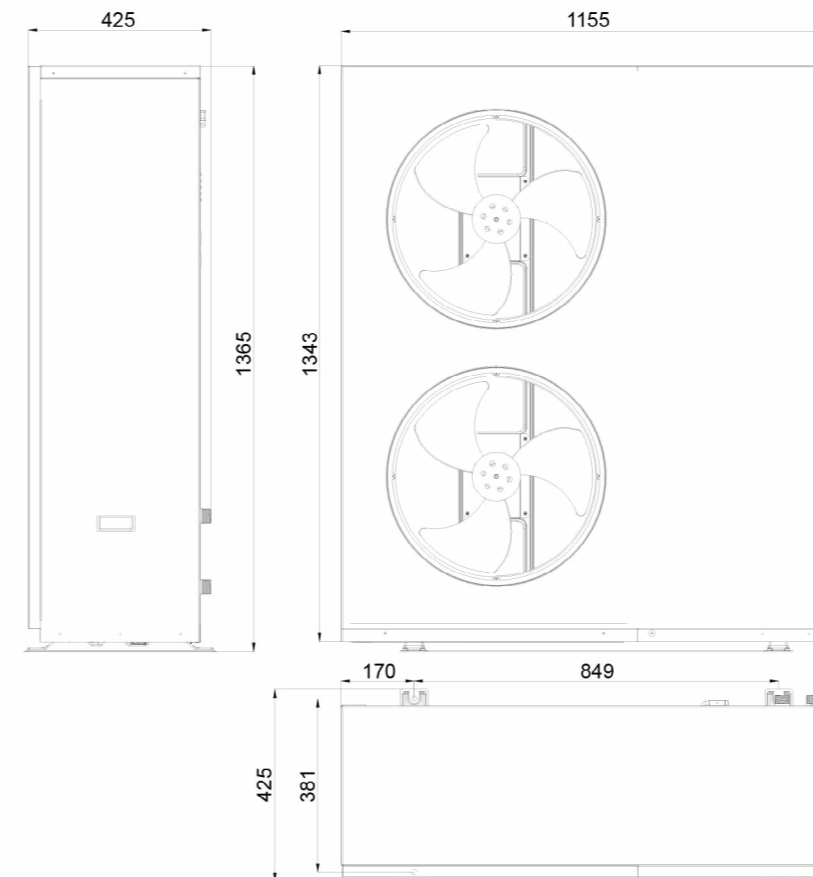



Preview the
Aerona 290
here

▶ SCAN &
WATCH



Grant Engineering (UK) Ltd
info@grantuk.com www.grantuk.com