



ADDENDUM
to
INSTALLATION INSTRUCTIONS
for
Aerona Air Source Heat Pumps

DOC.87-05/05 Rev.04 March 2013

ATTENTION INSTALLERS - UPDATED INFORMATION!

Your Grant Aerona Air Source Heat Pump has a number of recent changes that differ from the Installation Instructions supplied with the unit. These changes are part of our continued product improvement process.

Please read this Addendum and use the information in conjunction with the corresponding sections of the Installation Instructions (as indicated below).

After commissioning, please leave both the Installation Instructions and this Addendum sheet with the user for future reference.

Page 2

2.1 Specifications

Model		HPAW65	HPAW85	HPAW110	HPAW130
Heating Capacity	kW	6.9	8.4	10.9	12.3
Nominal running current*	A	9.1	10.7	14.0	16.1
COP @ air7°C/water 35°C		3.8	3.8	3.91	3.93
Sound press level @ 1metre	dB(A)	49.2	50.0	49.0	58.5

Please note that model HPAW155 is no longer available

*Does not include operation of 3kW back-up immersion heater

Page 2 &3

2.2 Dimensions

Model		HPAW65	HPAW85	HPAW110	HPAW130
Height (includes legs)	mm	790	1040	1040	1040
Width	mm	1120	1120	1120	1120
Depth (front to back)	mm	430	430	430	430
Height of legs	mm	125	125	125	125

Please note that model HPAW155 is no longer available

Note: The support legs have been shortened reducing the overall height of the unit by 125mm. There is a 'security eye' on the rear right hand leg for extra security if required.

2.6 Heat Pump Operating Sequences

The operating sequence has been altered such that the fan does not start immediately when there is a demand for the heat pump to operate. There is a delay of 60 seconds before the fan starts, with a further delay of 15 seconds before the compressors starts, as shown in the sequence diagram below.

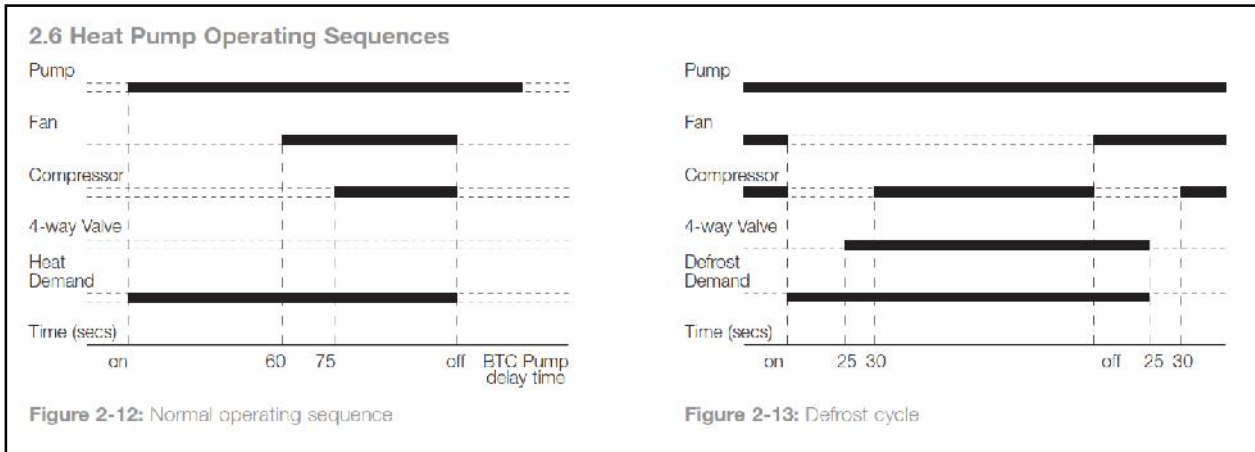

3.1 Position

The drip tray, fitted to the underside of the heat pump, can now be extended by up to 185mm at the rear of the unit to ensure that all water falling from the base of the unit drips into the drainage channel and not onto the concrete slab on which the unit is standing.

To extend the drip tray: Remove the two screws (at either end of the drip tray), pull out the extension, re-fit and tighten the screws. Ensure the edge of the drip tray extends beyond the concrete slab, i.e. over the drainage channel (refer to Figure 3-1 in the Installation manual).

Electrical Installation Requirements

Model	Nominal running current (A)*	MCB		Maximum Earth Loop Impedance ()	Minimum Cable size mm ²
		Rating (A)	Type		
HPAW65	9.1	32	C	0.72	6
HPAW85	10.7	32	C	0.72	6
HPAW110	14.0	32	C	0.72	6
HPAW130	16.1	45	C	0.46	10

*Does not include operation of 3kW back-up immersion heater

New electrical control panel and connection layout

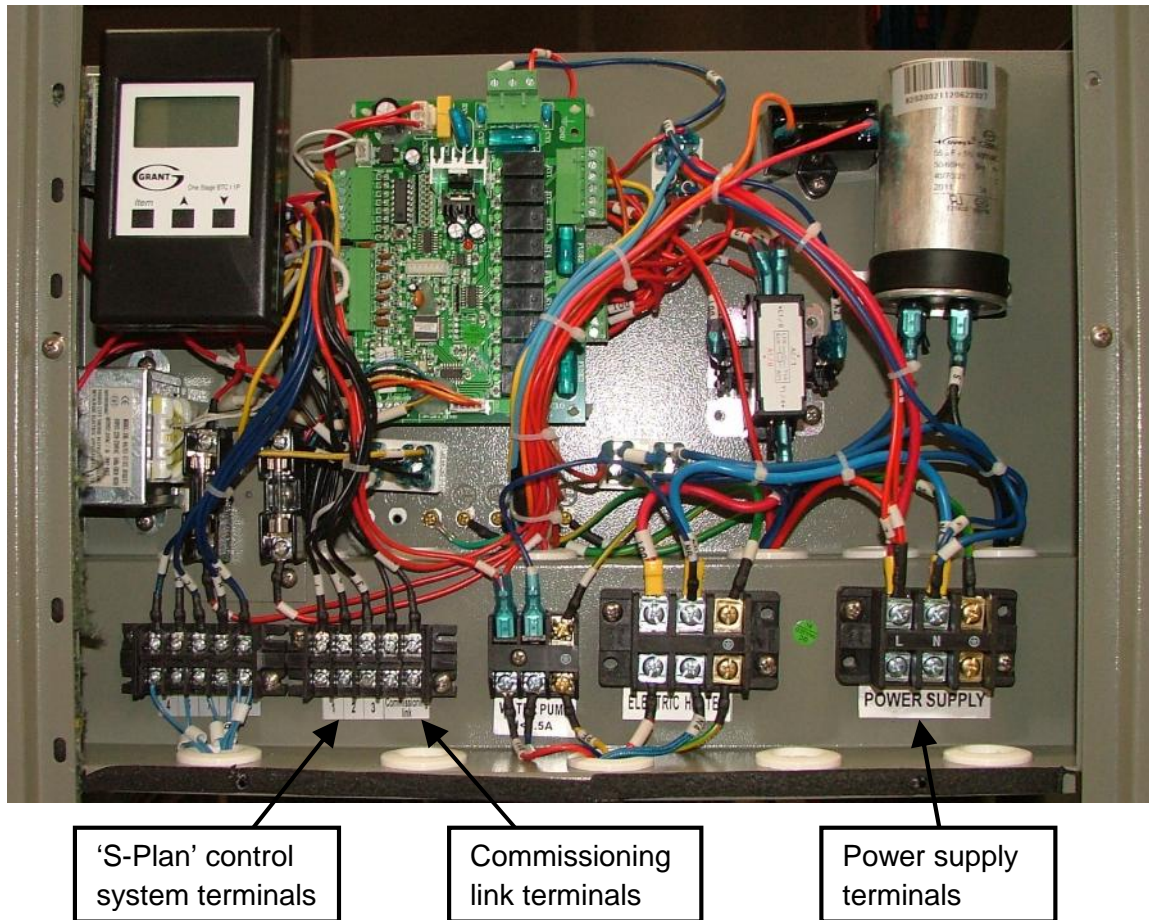

Commissioning connection link

There is now a 'Commissioning link' connection located in the control panel. When a wire link is connected between these two terminals, the weather compensation function of the BTC is overridden, allowing the unit to be commissioned under all weather conditions.

IMPORTANT: After commissioning, REMOVE the link. Failure to remove the link will result in the BTC weather compensation function NOT operating.

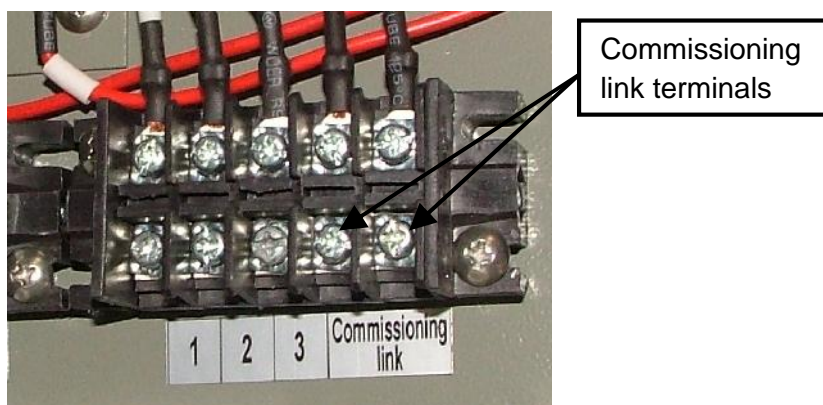

New Control PCB

This new PCB operates exactly as the previous version. The main difference is the use of push-on 'edge connectors', allowing easier removal and replacement of the PCB if required.

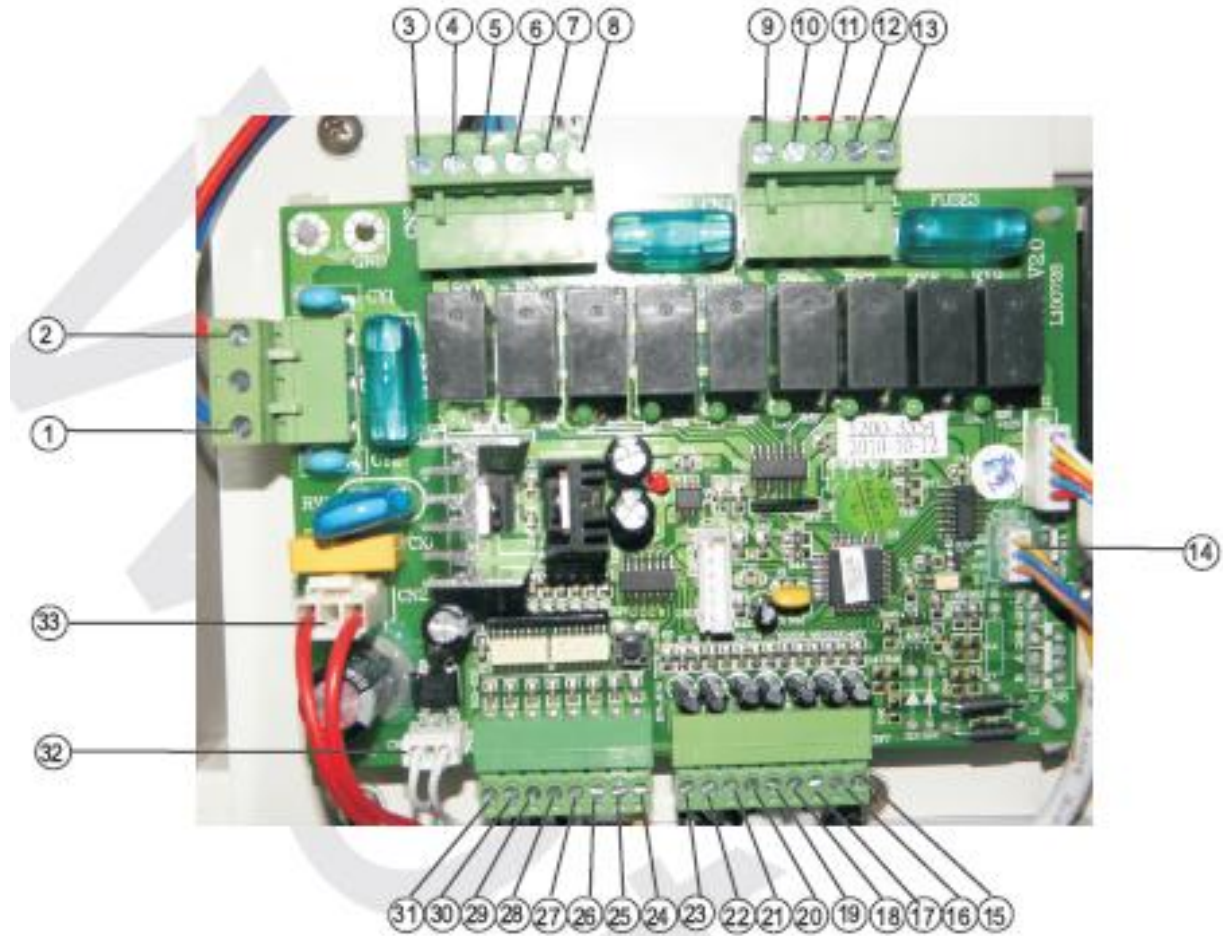



New PCB with edge connectors shown in place

Key to PCB Connections (refer to photograph above)

1.	Neutral	18.	Return Gas Temperature Sensor
2.	Live	19.	Coil Temperature Sensor
3.	Crank Case Heater	20.	Flow Temperature Sensor
4.	High Fan	21.	Return Temperature Sensor
5.	Low Fan	22.	Ambient Temperature Sensor
6.	4-way valve solenoid	23.	GND
7.	Compressor Relay	24.	GND
8.	Live Feed In	25.	Reserved
9.	Drip Tray Heater	26.	Reserved
10.	Link	27.	LP switch
11.	Immersion Element	28.	HP switch
12.	Circulation Pump	29.	Link
13.	Live Feed In	30.	Link
14.	ATC connection	31.	Commissioning Link
15.	GND	32.	12V AC connection
16.	Reserved	33.	220V AC connection
17.	Discharge Gas sensor		

11.2 Setting the ATC Controller

The 'standby' setting, and the corresponding  symbol, referred to in this section of the Installation Instructions is no longer present on the latest version of the ATC Controller.

The control will always be in the 'AUTOMATIC' setting, and the corresponding  symbol will be visible at the top of the display, provided that the unit is switched ON.

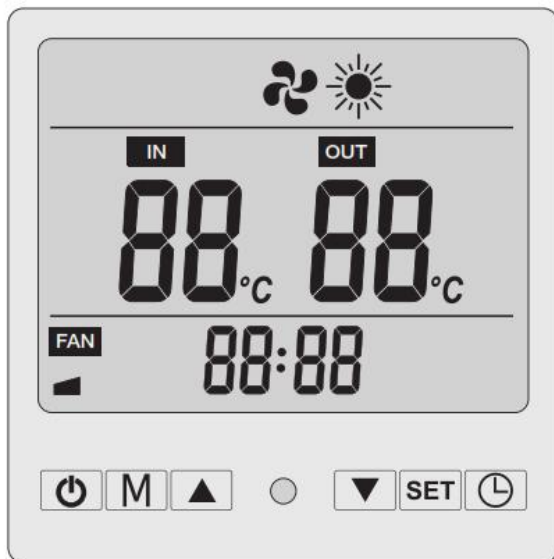



Figure 11-1: ATC display and buttons

The main purpose of the ATC controller is to give an overall maximum temperature control over the heat pump. In contrast, the BTC controller will give accurate control over both CH and HW temperatures, even if they each have different target temperatures.

The ATC controller must be set to either OFF or AUTOMATIC as follows:

1. OFF – This is indicated when NO temperature reading is shown in central section of the display.

In this setting the heat pump will not operate irrespective of any demand from either the heating system controls or the BTC controller.

Note – the  symbol will still be visible at the top of the display and the time will be shown at the bottom.

To switch heat pump ON

Press the  button. The flow and return water temperature will appear on the display and the heat pump will start.

To switch the heat pump OFF



Press the  button. The Flow and Return water temperature will disappear from the display and the heat pump will stop.

2. AUTOMATIC – This is indicated when the  symbol is visible at the top right of the display.

In this setting the heat pump is in a fully automatic condition (provided it is switched ON – see 1 above). Functions including normal running, defrosting, and frost protection are all operational.

Setting the ATC clock function

For the heat pump to operate correctly, the clock function of the ATC must be correctly set using the following procedure:

1. Press the 'SET' button. The hour segments will flash. Alter the hour setting using  the buttons.
2. Press the 'SET' button again and the minute segments will flash. Alter the minute setting using the  buttons.
3. Press the 'SET' button to confirm the time setting. The clock is now set.

NOTE - If no button is pressed for a period of 10 seconds, the ATC will automatically revert back to normal operation.

Setting the ATC parameters:

In order for the heat pump to operate correctly, the ATC operating parameters must be set as indicated in the table on page 31.

IMPORTANT Please note that ALL operating parameters MUST be checked during commissioning and, if not correct, set to the value given in the table on page 31.

Incorrectly set parameters will adversely affect the operation and efficiency of the heat pump and will invalidate all warranties.

To check the parameter settings, press either of the  buttons to enter the list of parameters. Then repeatedly press either of the buttons to scroll through the different parameters. Check the setting of each parameter against the correct values listed in the table on page 31 of the Installation instructions supplied with the ASHP.

IMPORTANT

Only set the parameters as shown in the table on page 31 unless instructed otherwise by Grant UK.

To alter the setting of any parameter, press the 'SET' button once, then use the  buttons to alter the value of that parameter. Once set correctly, press the 'SET' button to exit back to the parameter list and continue to check settings.

To exit the parameter list stop pressing the  buttons. The ATC will automatically return to the normal operation.

NOTE - If no button is pressed for a period of 10 seconds, the ATC will automatically revert back to normal operation.

11.3 Additional Operating Information about the ATC

Fan Motor Operation

With Parameter 'A' set to either 0 or 1; the fan operates at a single constant speed, as follows:

- a) When in heating mode (CH or HW), the fan motor starts after 60 seconds and the compressor then starts 15 seconds later.
- b) During defrosting, the fan motor does not operate.

Circulating Pump Operation

In all conditions, the circulating pump will operate when the ambient air temperature falls below 0°C. This is part of the frost protection and cannot be adjusted by the installer or user.

Electric Immersion Heater

The electric Immersion backup heater will be energised to increase the heat output of the heat pump when:

The ATC set to ON and with a demand (for heating or hot water) AND either

The ambient temperature is below the Parameter 'd' setting (default setting 3°C)

OR

The Return water temperature falls to less than Parameter '0' setting (default setting 2°C)

The electric Immersion heater will be switched off when the Return water temperature reaches Parameter '1' setting (default setting 47°C).

For all Parameter values, refer to Table of ATC Parameters on page 31 of the Installation instructions supplied with the ASHP.

Note: The electric immersion element will be energised automatically during the heat pump defrost cycle.

Bivalent Systems

In a Bivalent system the electric immersion element is disconnected and the switched live for the back-up boiler is taken from the immersion element live terminal – refer to Figures 8-7 and 8-11. Thus the back-up boiler will be energised under the same parameters as given above for the electric immersion element.

Frost Protection

Regardless of whether the ATC is ON or OFF (i.e. when no Temperatures are displayed on the ATC) the Frost protection will operate. When the Return water temperature is equal or less than Parameter 0 (default setting 2°C) AND the ambient air temperature is equal or less than 0°C) the Heat Pump and circulating pump will start.

The Heat Pump and circulating pump will remain ON until the Return water temperature is 12°C or greater.

NOTE: When the heat pump is operating (as described above) to provide Frost Protection the code 'PP7' will be displayed on the ATC. This does NOT indicate a fault condition.

Trace Heater Operation

The trace heater will be switched on when the ambient air temperature falls to 7°C or below. This is automatic and the temperature non adjustable.

