



Part No. DOC 80 Rev. 00 August 2008

USER, INSTALLATION
and
SERVICING INSTRUCTIONS

GRANT VORTEX ECO Condensing Oil Boiler range

**Vortex Eco Utility
with outputs from 15 to 35 kW**

For use with Kerosene only

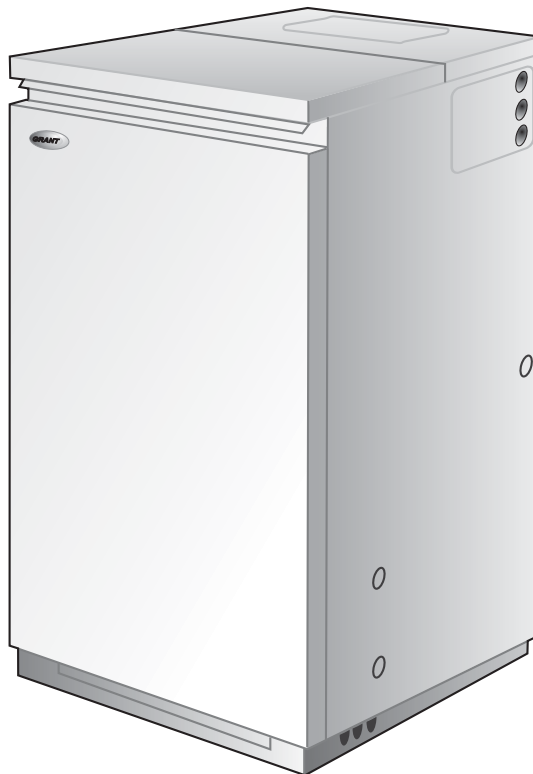

After installing the boiler leave these instructions with the User

This appliance is deemed a controlled service and specific regional statutory requirements may be applicable

LIST OF CONTENTS

Section	Subject	Page
1	Introduction	3
2	User instructions	4
3	Boiler technical information	7
4	General boiler information	11
5	Condensate disposal	27
6	Boiler installation	31
7	Commissioning	37
8	Information for the user	38
9	Boiler servicing	38
10	Wiring diagrams	42
11	Fault finding	43
12	Boiler spares	45
13	Burner spares	46
14	Health and safety information	47
15	EC declaration of conformity	48

COMMISSIONING REPORT

Date:

Commissioning engineer: Tel. No:

Boiler model/output: kW Fuel type: Kerosene

Nozzle size: Pump pressure: Air setting:

Flue gas % CO₂: Net flue gas temp: Smoke No:

SERVICE LOG

It is recommended that the boiler should be regularly serviced, at least once a year, and the details entered in the Boiler Handbook by the service engineer.

1.1 How a condensing boiler works

During the combustion process, hydrogen and oxygen combine to produce heat and water vapour. The water vapour produced is in the form of superheated steam in the heat exchanger. This superheated steam contains sensible heat (available heat) and latent heat (heat locked up in the flue gas). A conventional boiler cannot recover any of the latent heat and this energy is lost to the atmosphere through the flue.

The Grant Vortex condensing boiler contains an extra heat exchanger which is designed to recover the latent heat normally lost by a conventional boiler. It does this by cooling the flue gases to below 90° C, thus extracting more sensible heat and some of the latent heat. This is achieved by cooling the flue gases to their dew point (approximately 55° C).

To ensure maximum efficiency, the boiler return temperature should be 55° C or less, this will enable the latent heat to be condensed out of the flue gases. The boiler will achieve nett thermal efficiencies of 100%.

To achieve maximum performance from the Grant Vortex boiler, it is recommended that the heating system is designed so that a temperature differential of 20° C between the flow and return is maintained. The use of modulating circulating pumps (now widely available) and effective control systems should be considered.

The Grant Vortex boiler will however still operate at extremely high efficiencies even when it is not in condensing mode and therefore is suitable for fitting to an existing heating system without alteration to the radiator sizes. The boiler is capable of a maximum flow temperature of 75° C.

1.2 Heating system design considerations

To achieve the maximum efficiencies possible from the Grant Vortex boiler, the heating system should be designed to the following parameters:

Radiators:-

Flow temperature	70° C
Return temperature	50° C
Differential	20° C

Underfloor:-

Flow temperature	50° C
Return temperature	40° C
Differential	10° C

- 1 Size radiators with a mean water temperature of 60° C.
- 2 Design system controls with programmable room thermostats or use weather compensating controls to maintain return temperatures below 55° C.

The boiler should not be allowed to operate with return temperatures of less than 40° C when the system is up to operating temperature.

- 3 The use of a pipe stat is recommended to control the return temperature when using weather compensating controls.

2 - USER INSTRUCTIONS

2.1 About your boiler

The boiler is fully automatic once switched on, providing central heating (and also heating your domestic hot water if you have a hot water cylinder fitted).

A 'mains on' neon, see Fig. A, lights when the boiler is switched on, but does not necessarily indicate the burner is firing.

If your system includes a programmer, the boiler will provide hot water and central heating during the periods set on the programmer.

2.2 Boiler controls (see Fig. A)

To gain access to the controls, pull the front panel forward at the top to disengage the fixing clips then lift it up and off the boiler. To replace locate the bottom of the panel over the fixing tags then push it towards the boiler to engage the fixing clips.

2.3 Lighting your boiler (see Fig. A)

- 1 **Ensure that** - There is sufficient fuel, of the correct type, in the supply tank and all fuel supply valves are open. The water supply is on. The electricity supply to the boiler is off. The boiler On/Off switch is set to OFF. The room thermostat (if fitted) is at the desired setting. The boiler thermostat is set to the required setting (see Section 2.7).
- 2 Switch on the electricity supply to the boiler.
- 3 Set the On/Off switch to ON and, if fitted, the programmer (CH or HW) to ON.
The boiler will now light automatically.
- 4 If you have a programmer fitted in your system, refer to the instructions supplied with the programmer and set the programmer. Set the HW and CH functions to TIMED. The boiler will now operate during the 'on' periods set on the programmer.

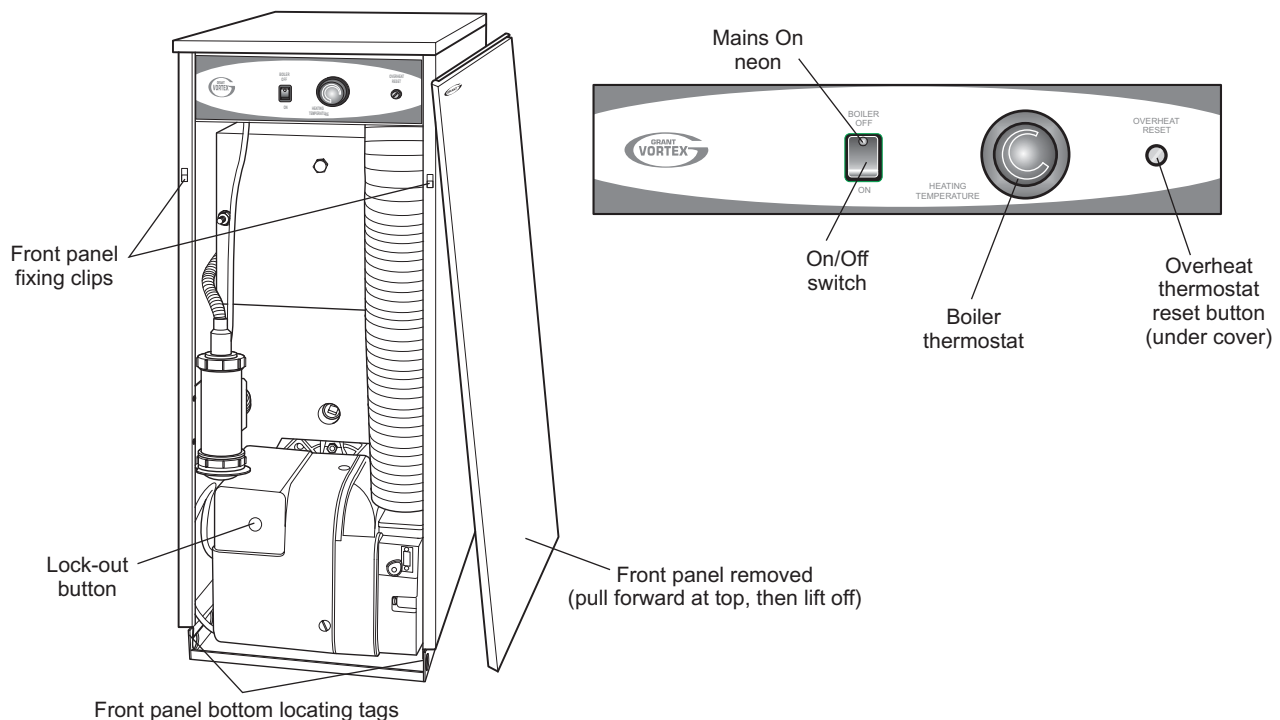

Fig. A Boiler controls

2.4 Turning off your boiler (see Fig. A)

For short periods - Set the On/Off to OFF.
To restart, simply set the switch to ON.

For long periods: Set the On/Off switch to OFF and switch off the electricity supply to the boiler. If required, the fuel supply valve may be closed and the water and electricity supplies turned off at the mains.

To restart, refer to the full lighting instructions given in Section 2.3.

2.5 Points to check if burner fails to light

- 1 Check that the boiler On/Off switch is ON.
- 2 Check that the programmer (if fitted) is working and is in an 'on' period.
- 3 Check that all thermostats are set to the desired setting and are calling for heat.
- 4 Check if the burner 'Lock-out' reset button (on the burner) is lit. If it is, press it to start the burner. If the burner fails to light and goes to 'Lock-out' again, check that you have sufficient fuel in the storage tank and that the fuel supply valve is open. Check that the fire valve in the oil supply line has not tripped
- 5 Ensure that a fuse has not blown or that the electricity supply has not failed.
- 6 Check to see if the safety thermostat has operated (see Section 2.7).

If the burner still fails to light after carrying out these checks then a fault exists. Switch off the electricity supply to the boiler and contact your Service engineer.

2.6 About your fuel

Grant Vortex boilers only operate on Class C2 Kerosene to BS 2869:1998.

You should always quote this type of fuel when ordering from your supplier.

Do not wait until the fuel runs out before you order some more. Sludge in the bottom of the tank may be drawn into the fuel lines. If it is possible, switch off the boiler when the new supply is delivered and leave the fuel to settle for an hour before restarting the boiler.

2.7 General notes and care of your system

- 1 **Boiler thermostat** - This control allows the temperature of the water leaving the boiler to heat the radiators and domestic hot water to be adjusted.

Note: If you have a cylinder thermostat on your hot water cylinder, this will control the temperature of your domestic hot water. The boiler thermostat setting must be equal to or above the cylinder thermostat setting to enable the cylinder thermostat to control the domestic hot water system.

- 2 **Burner Lock-out reset button** - If there is a burner malfunction, a built-in safety circuit switches the burner off and the 'Lock-out' reset button (on the burner) will light. Usually such malfunctions are short lived and pressing the reset button will restore normal operation.

If the burner continually goes to 'Lock-out' a fault exists **or** the fuel supply is low. If you have sufficient fuel, you will need to call your Service engineer.
- 3 **Safety thermostat** - Your boiler is fitted with a safety overheat thermostat which will automatically switch off the boiler in the case of a control malfunction causing overheating.

If your boiler goes off and you try to light it but nothing happens and the 'Lock-out' reset button on the burner is not lit, the overheat thermostat has probably operated. The boiler will not light until the thermostat is reset. To reset, unscrew the small plastic cap (see Fig. A), press the button then replace the cap.

If this condition continually repeats, contact your Service engineer.
- 4 **Programmer (if fitted)** - Refer to the instructions supplied with the Programmer.
- 5 **Ventilation** - Always ensure that the boiler has adequate ventilation. Any ventilation openings provided by the Installer **must not** be obstructed. Periodically check that they are clear.

Do not attempt to 'box in' the boiler or build a compartment around it before consulting your Installer.

Do not place any combustible material around or on the boiler or flue pipe.
- 6 **Flue terminal** - The flue terminal on the outside wall **must not** be obstructed or damaged.

In severe conditions check that the terminal does not become blocked by snow.

2 - USER INSTRUCTIONS

7 Frost protection - Your Installer may have fitted a frost thermostat. If not, and you are likely to be away for a short time, leave the boiler on with the boiler thermostat set at a low setting. For longer periods the boiler and system should be drained. Contact your Service engineer for draining and filling the system.

8 Cleaning and servicing - Lightly wipe over the case with a damp cloth and a little detergent. **Do not** use abrasive pads or cleaners.

You must have your boiler serviced at least once a year to ensure safe and efficient operation. Contact your Service engineer for further details.

9 Failure of electricity supply - If the electricity supply fails, the boiler will not operate. It should relight automatically when the supply is restored.

If a programmer is fitted it will retain the time settings for up to 24 hours and will not have to be reset to the correct time of day when the supply is restored (the display remains for up to 1 hour, but will re-appear when the supply is restored).

2.8 Electricity supply

The boiler requires a 230/240 V ~ 50 Hz supply. It must be protected by a 5 Amp fuse.

Warning: This appliance must be earthed.

2.9 Sealed central heating system

If your boiler is operating on a sealed heating system, the installer will have pressurised the system and should have told you (or set it on the pressure gauge) the system pressure when cold (this is normally between 0.5 and 1.0 bar, which will increase slightly when hot). If the pressure (when cold) is below the set pressure mentioned above, you can re-pressurise the system. If the system requires frequent re-pressurising, ask your Installer or Service engineer to check the heating system for leaks and to check the expansion vessel air charge.

The boiler or system will be fitted with an automatic air vent to remove air from the system. Any air trapped in the radiators should be removed by venting the radiators using the vent screw at the top of each radiator. Only vent a radiator if the top is cool and the bottom is hot. Excessive venting will reduce the system pressure, so only vent when necessary and check the system pressure as mentioned above. Re-pressurise the system if necessary.

The boiler or system may be fitted with a safety valve to release excess pressure from the system. If water or steam is emitted from the end of the safety valve discharge pipe, switch off the boiler and contact your Installer or Service engineer.

The expansion vessel air charge must be checked annually. Failure to maintain an adequate air charge in the vessel may invalidate the warranty.

To re-pressurise the system by adding water:

- 1 Only add water to the system when it is cold and the boiler is off. **Do not overfill.**
- 2 Ensure the flexible filling loop (see Fig. B) is connected and that the shut off valve connecting it to the boiler is open and the double check valve at the front is closed.
A valve is open when the operating lever is in line with the valve, and closed when it is at right angles to it.
- 3 Gradually open the double check valve on the front of the filling loop until water is heard to flow. When the black needle of the pressure gauge is between 0.5 and 1 bar, close the valve.
- 4 Vent each radiator in turn, starting with the lowest one in the system, to remove air.
- 5 Continue to fill the system until the pressure gauge indicates between 0.5 and 1.0 bar. Close the fill point valve.
- 6 Repeat steps 4 and 5 as required.
- 7 Close the valves either side of the filling loop and disconnect the loop.

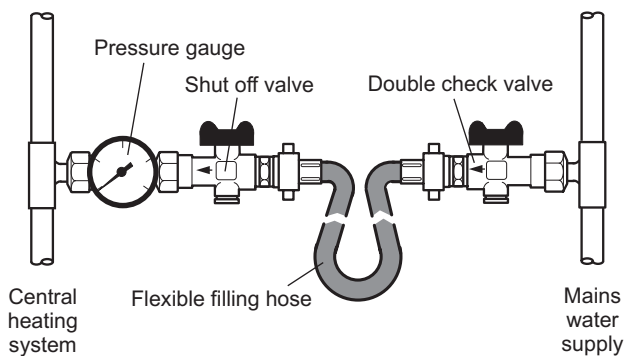

Sealed system filling loop arrangement - Fig. B

3- BOILER TECHNICAL INFORMATION

3.1 Boiler technical data

Model	Vortex Eco Utility			
	15/21	15/26	26/35	
Water content	litre	13	13	19
	gal	2.9	2.9	4.2
* Weight (dry)	kg	103	103	121
	lb	227	227	267
Max. heat output (kerosene)	kW	20.7	25.6	34.7
	Btu/h	70 600	87 350	118 400
Flow connection	22 mm			
Return connection	22 mm			
Min. flow rate ($\Delta T=10^{\circ}\text{C}$) l/h	1 780	2 200	2 980	
Min. flow rate ($\Delta T=20^{\circ}\text{C}$) l/h	890	1 100	1 490	
Condensate connection	22 mm (only connect plastic pipe)			
Flue diameter (conventional)	100 mm			
Waterside resistance				
Flow/Return temp. diff. of 10°C	28.5 mbar			
Flow/Return temp. diff. of 20°C	10 mbar			
Maximum static head	28 m			
Minimum circulating head	1m			
Boiler thermostat range	65 to 75°C			
Limit (safety) stat shut off temp	$111^{\circ}\text{C} \pm 3^{\circ}\text{C}$			
Max. hearth temperature	Less than 50°C			
Electricity supply	230/240 V ~ 50 Hz Fused at 3 Amp			
Motor power	Watts	90		
Starting current	Amps	4.2		
Running current	Amps	0.85		
Oil connection	$\frac{1}{4}$ " BSP Male (on end of flexible fuel hose)			
Conventional flue	Minimum flue draught - 8.7 N/m^2 (0.035 in wg)			
	Maximum flue draught - 37 N/m^2 (0.15 in wg)			
Max operating press - sealed sys	2.5 bar			
Max operating press - open sys	2.5 bar			

* Weight includes burner but excludes flue.

3 - BOILER TECHNICAL INFORMATION

3.2 Sealed system data - Utility models with sealed system kit

Heating system pressure (cold)	Maximum 1.0 bar, Minimum 0.5 bar
Operating pressure of pressure relief valve	2.5 bar
Expansion vessel size	12 litres (pre-charged at 1 bar)
Max heating system volume (including boiler)*	128 litres (approximately)
Cold water mains connection (for filling loop)	15 mm compression (provided)
Pressure relief valve discharge connection	15 mm compression (provided)

* Based on vessel charge and system cold fill pressure of 0.5 bar

3.3 Grant Vortex Eco oil boilers using Class C2 kerosene

Note: Grant Vortex Eco boilers are only for use with kerosene.

Model and burner type	Heat Output		SEDBUK efficiency (%)	Nozzle	Oil press. (bar)	Smoke No.	Burner head type	Burner head/disc setting	Fuel flow rate (kg/h)	Flue gas temp °C		CO ₂ (%)
	(kW)	(Btu/h)								Flue	Door	
15/21 Riello RDB2.2	15.1	51 500	93.0	0.50/80°EH	7.0	0 - 1	T1	Disc setting B	1.29	70 - 75	155 - 160	11 - 12
	* 18.1	61 750		0.55/80°EH	7.5	0 - 1	T1	Disc setting C	1.53	75 - 80	175 - 180	11 - 12
	20.7	70 600		0.60/80°EH	8.5	0 - 1	T1	Disc setting C	1.78	80 - 85	185 - 190	11 - 12
21/26 Riello RDB2.2	20.7	70 600	92.4	0.60/80°EH	8.5	0 - 1	T1	Fixed	1.78	85 - 90	195 - 200	11 - 12
	* 22.7	77 500		0.65/80°EH	8.5	0 - 1	T2	Fixed	1.95	85 - 90	205 - 210	11 - 12
	25.6	87 350		0.75/80°EH	8.0	0 - 1	T2	Fixed	2.19	90 - 95	215 - 220	11 - 12
26/35 Riello RDB2.2	25.6	87 350	92.1	0.75/80°EH	8.0	0 - 1	T2	Fixed	2.19	75 - 80	190 - 195	11 - 12
	* 30.8	105 100		0.85/80°EH	9.1	0 - 1	T3	Fixed	2.65	85 - 90	215 - 220	11 - 12
	34.7	118 400		1.00/80°EH	8.0	0 - 1	T3	Fixed	2.93	90 - 95	220 - 225	11 - 12

Notes:

- The data given above is approximate only and based on the boiler using a low level flue.
- The above settings may have to be adjusted on site for the correct operation of the burner.
- Gas Oil is **not** suitable for use with the Grant Vortex Eco boiler range.
- The net flue gas temperatures given above are ± 10%.
- When commissioning the air damper **must** be adjusted to obtain the correct CO₂ level.
- * Factory settings: 15/21 - 18.1 kW, 21/26 - 22.7 kW, 26/35 - 30.8 kW.
- The combustion door test point may be used for CO₂ and smoke readings only. Do not use this test point for temperature or efficiency readings.
- When setting the 15/21 to 15.1 kW output the burner air adjuster disc requires repositioning. Refer to Section 7 Commissioning.
When setting the 26/35 to 25.6 kW output the combustion head must be changed. Refer to Section 9.4 Cleaning the burner.
- The installer **must** amend the boiler data label if the output is changed.

Flue gas analysis

To allow the boiler to be commissioned and serviced, the boiler is supplied with a combustion test point on the front cleaning door. When this test point is used please note the following:

- The test point is for CO₂ and smoke readings only.
- The boiler efficiency and temperature must be taken from the flue test point on high level and vertical flue adaptors.
- Low level flues do not contain a test point. The temperature and efficiency readings must be taken from the flue terminal.

3 - BOILER TECHNICAL INFORMATION

3.4 Boiler dimensions

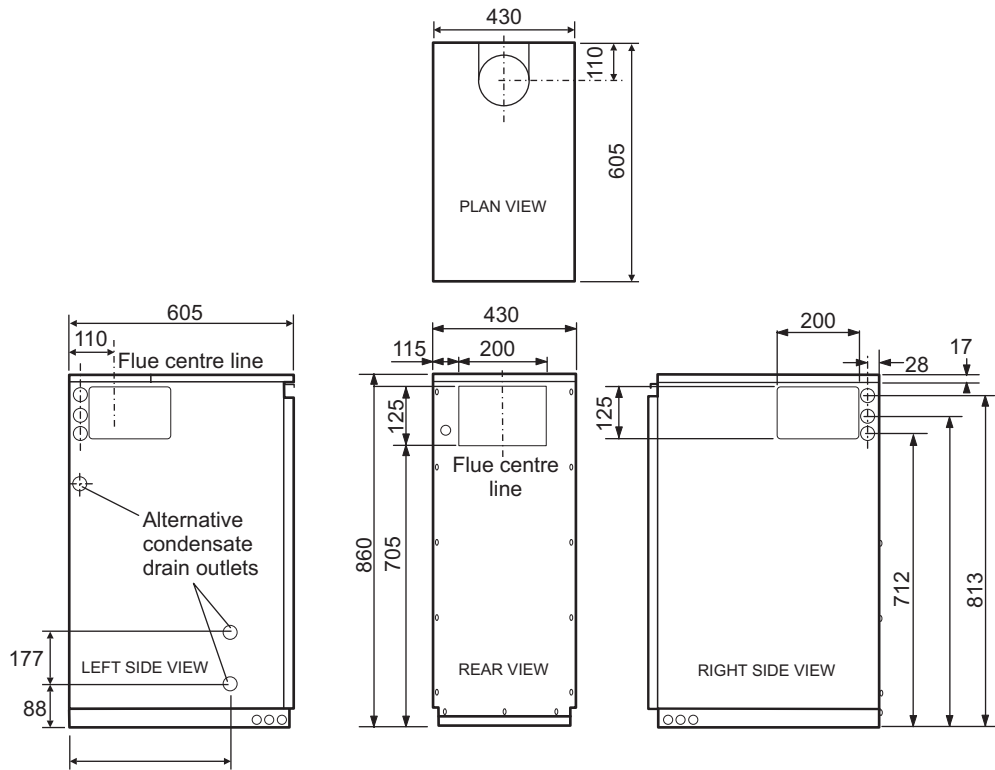

Fig. 1a - 15/21, 21/26 Utility dimensions

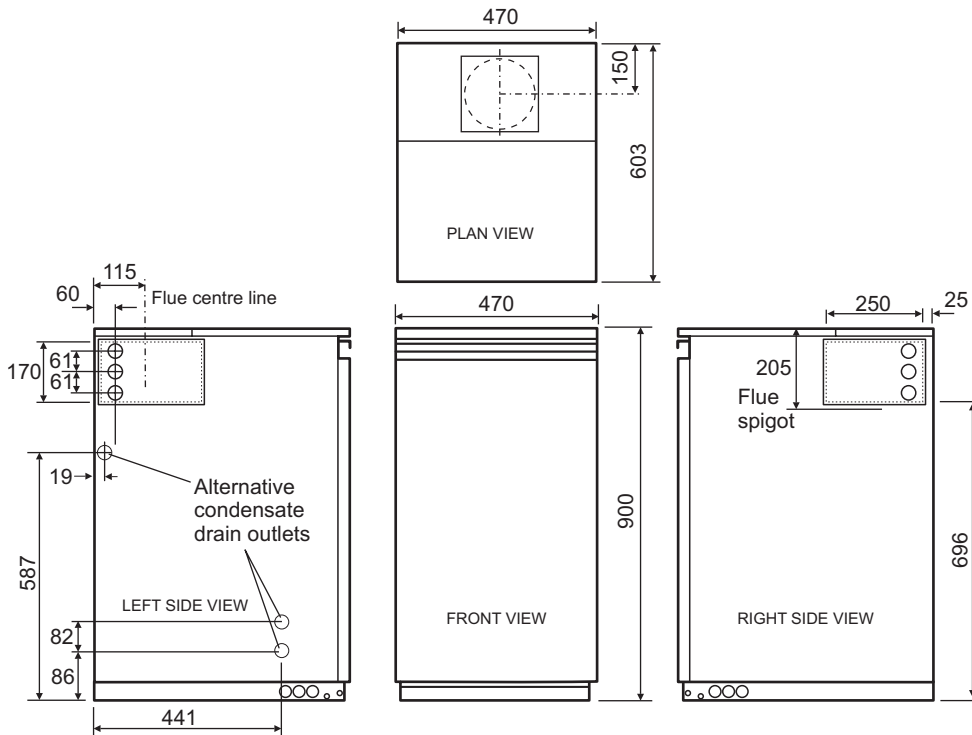

Fig. 1b - 26/35 Utility dimensions

4.1 Boiler description

The Grant Vortex range of automatic pressure jet oil boilers have been designed for use with a fully pumped central heating system with indirect domestic hot water cylinder. They are not suitable for use with either a direct cylinder or a 'primatic' cylinder or gravity hot water.

The boilers are suitable for use on open vented or sealed central heating systems. System models are supplied with the necessary components factory fitted. See Section 4.13.

All models are supplied with the control panel and burner factory fitted.

The boilers can be connected to either a conventional flue system or a balanced flue system, as required.

For Conventional flue applications where a chimney is to be lined - Grant recommends the use of the Grant 'Orange' flue system, specifically designed for the Vortex range of condensing boilers. Refer to Section 4.7 for further details.

Where a rigid conventional flue - either internal or external - is required, Grant recommends the use of the Grant 'Green' and 'Orange' flue system components. As no flue adaptor is supplied with the boiler it will be necessary to purchase the Grant CF adaptor kit in order to correctly connect the 'Green' and 'Orange' system flue components to the boiler.

Flue adaptor kit - **Ref. CFA15/70** - is used for all Vortex models from 15 to 70 kW as they all can use the 100 mm 'Green' and 'Orange' system components to construct a flue of maximum vertical height 8 metres.

Important: The flue system materials and construction **MUST** be suitable for use with oil-fired condensing boilers. Failure to fit a suitable conventional flue may invalidate the warranty on the boiler.

Fitting instructions for the Low level concentric, High level and Vertical balanced flue kits are supplied with the kits. Where a balanced flue system is required, the following flue kits are available from Grant Engineering (UK) Limited.

Refer to Section 4.8 for further details.

Yellow system Standard low level concentric balanced flue - components available:

Low level concentric balanced flue short
Extensions 225 mm, 450 mm and 675 mm
90° extension elbow
45° extension elbow
45° elbow

Green system Standard external high level/vertical flue starter kit (room sealed) - components available:

External high level/vertical flue starter kit short (room sealed)
Extensions 150 mm, 250 mm, 450 mm, 950 mm, adjustable 195 to 270 mm and 45° elbow
High level terminal
Vertical terminal

White system High level and vertical concentric balanced flue kit - components available:

Extensions 225 mm, 450 mm, 950 mm, adjustable 275 to 450 mm and 45° elbow
Vertical concentric balanced flue kit
Extensions 225 mm, 450 mm, 950 mm, adjustable 275 to 450 mm and 45° elbow

Red system (15/21 and 15/26 only) A flexible vertical balanced flue system designed to be fitted inside an existing masonry chimney.

Flue extensions and 45° elbows from the Grant 'White' system may be used to extend the flue system between the boiler and the flexible section of the system.

4.2 Boiler components

All burners are pre-set for use with kerosene and are supplied ready to connect to a single pipe fuel supply system with a loose flexible fuel line and $\frac{3}{8}$ " to $\frac{1}{4}$ " BSP male adaptor supplied with the boiler.

If required, an additional flexible fuel line (600 mm) and $\frac{3}{8}$ " to $\frac{1}{4}$ " BSP male adaptor are available to purchase from Grant Engineering (UK) Limited, for two-pipe oil supply systems, Part No. RBS104.

The temperature of the water leaving the boiler to heat the radiators and hot water cylinder is User adjustable.

The boiler is fitted with an overheat thermostat (which allows it to be used on a sealed central heating system) which will automatically switch off the boiler if the heat exchanger exceeds a pre-set temperature of $111^{\circ}\text{C} \pm 3^{\circ}\text{C}$.

The control panel is fitted with an ON/OFF switch, boiler thermostat control knob and the manual reset button for the overheat thermostat.

4 - GENERAL BOILER INFORMATION

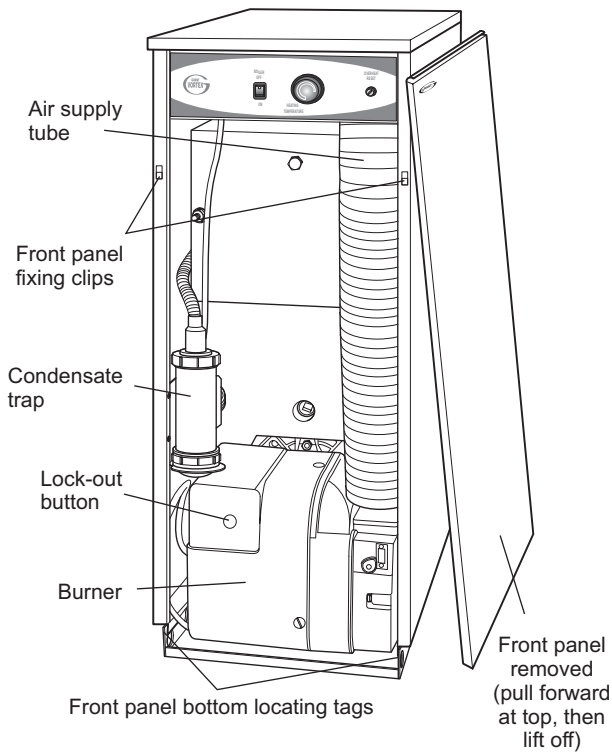

Fig. 2 - Components

4.3 Regulations to comply with

Installation of a Grant Vortex boiler must be in accordance with the following recommendations:-

- a Building Regulations for England and Wales, and the Building Standards for Scotland issued by the Department of the Environment and any local Byelaws etc.
- b Model and local Water Undertaking Byelaws.
- c Applicable Control of Pollution Regulations.
- d The following OFTEC requirements:-
 - OFST 100 Polythene oil storage tanks for distillate fuels.
 - OFST 200 Fuel oil storage tanks and tank bunds for use with distillate fuels, lubrication oils and waste oils.

Further information may be obtained from the OFTEC Technical Information Book 3 (Installation requirements for oil fired boilers and oil storage tanks).

The installation should also be in accordance with the latest edition of the following British Standard Codes of Practice:-

BS 715	Metal flue pipes, fittings, terminals and accessories.
BS 799:5	Oil storage tanks.
BS 1181	Clay flue linings and flue terminals.
BS 4543:3	Factory made insulated chimneys for oil fired appliances.
BS 4876	Performance requirements for oil burning appliances.
BS 5410:1	Code of Practice for oil firing appliances.
BS 5449	Forced circulation hot water systems.
BS 7593	Code of Practice for treatment of water in heating systems.
BS 7671	Requirements for electrical installations, IEE Wiring Regulations.

Failure to install and commission appliances correctly may invalidate the boiler warranty.

IMPORTANT

Before starting any work on the boiler, or fuel supply please read the health and safety information given in Section 14 on page 47.

4.4 Fuel supply

4.4.1 Fuel storage

The tank should be positioned in accordance with the recommendations given in BS 5410:1:1997, which gives details of filling, maintenance and protection from fire.

A steel tank may be used and must be constructed to BS 799:5:1987 and OFS T200.

A galvanised tank must not be used.

A plastic tank may be used and must comply with OFS T100.

Note: Plastic tanks should be adequately and uniformly supported on a smooth level surface, across their entire base area.

Regional statutory requirements may deem this appliance to be a 'controlled service'. Where this is the case, it is a legal requirement that the appliance is installed and commissioned either under the remit of building control or by a 'Competent person' such as a suitably qualified Oftec registered technician.

4 - GENERAL BOILER INFORMATION

4.4.2 Fuel pipes

- 1 Fuel supply pipes should be of copper tubing with an external diameter of at least 10 mm. Galvanised pipe must not be used. All pipe connections should preferably use flared fittings. Soldered connections **must not** be used on oil pipes.
- 2 Flexible pipes must not be used outside the boiler case.
- 3 A remote sensing fire valve must be installed in the fuel supply line (outside) where it enters the building, with the sensing head located above the burner. Recommendations are given in BS 5410:1:1997.
- 4 A metal bowl type filter with a replaceable micronic filter must be fitted in the fuel supply line adjacent to the boiler. A shut-off valve should be fitted before the filter, to allow the filter to be serviced.
- 5 A flexible fuel hose, adaptor and $\frac{1}{4}$ " BSP isolation valve are supplied loose with the boiler for the final connection to the burner. If a two pipe system or 'Tiger Loop' type de-aerator is used, an additional flexible fuel hose (600 mm) and $\frac{3}{8}$ " to $\frac{1}{4}$ " BSP male adaptor are available to purchase from Grant Engineering (UK) Limited, Part No. RBS104.
- 6 Metal braided flexible hoses should be replaced annually when the boiler is serviced. Long life flexible pipes should be inspected annually and replaced at least every 60 months.

4.4.3 Single pipe system - (See Fig. 3)

- 1 Where the storage tank outlet is above the burner the single pipe system should be used. The height of the tank above the burner limits the length of pipe run from the tank to the burner.
- 2 As supplied the burner is suitable for a single pipe system.

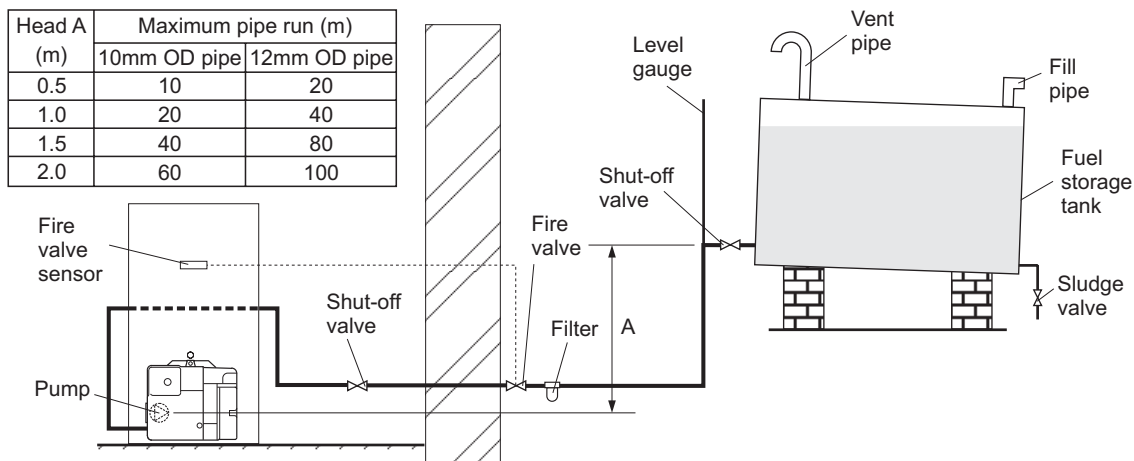

Fig. 3 - Single pipe system

4.4.4 Two pipe system - (See Fig. 4)

- 1 When the storage tank outlet is below the burner, the two pipe system should be used. The pipe runs should be as shown in Fig. 4. The return pipe should be at the same level in the tank as the supply pipe, both being 75 to 100 mm above the base of the tank. The pipe ends should be a sufficient distance apart so as to prevent any sediment disturbed by the return entering the supply pipe.
 - 2 Avoid the bottom of the tank being more than 3 m below the burner.
 - 3 A non-return valve should be fitted in the supply pipe together with the filter and fire valve. A non-return valve should be fitted in the return pipe if the top of the tank is above the burner.
- 4 To be used with a two-pipe system, the burner **must** be fitted with an additional flexible fuel hose (a flexible fuel hose (600 mm) and $\frac{3}{8}$ " to $\frac{1}{4}$ " BSP male adaptor are available to purchase from Grant Engineering (UK) Limited), Part No. RBS104. See Section 4.4.6.
- 5 The pump vacuum should not exceed 0.4 bar. Beyond this limit gas is released from the oil.

For guidance on installation of top outlet fuel tanks and suction oil supply sizing, see OFTEC booklet T1/139. Available at www.oftec.org.uk.

4 - GENERAL BOILER INFORMATION

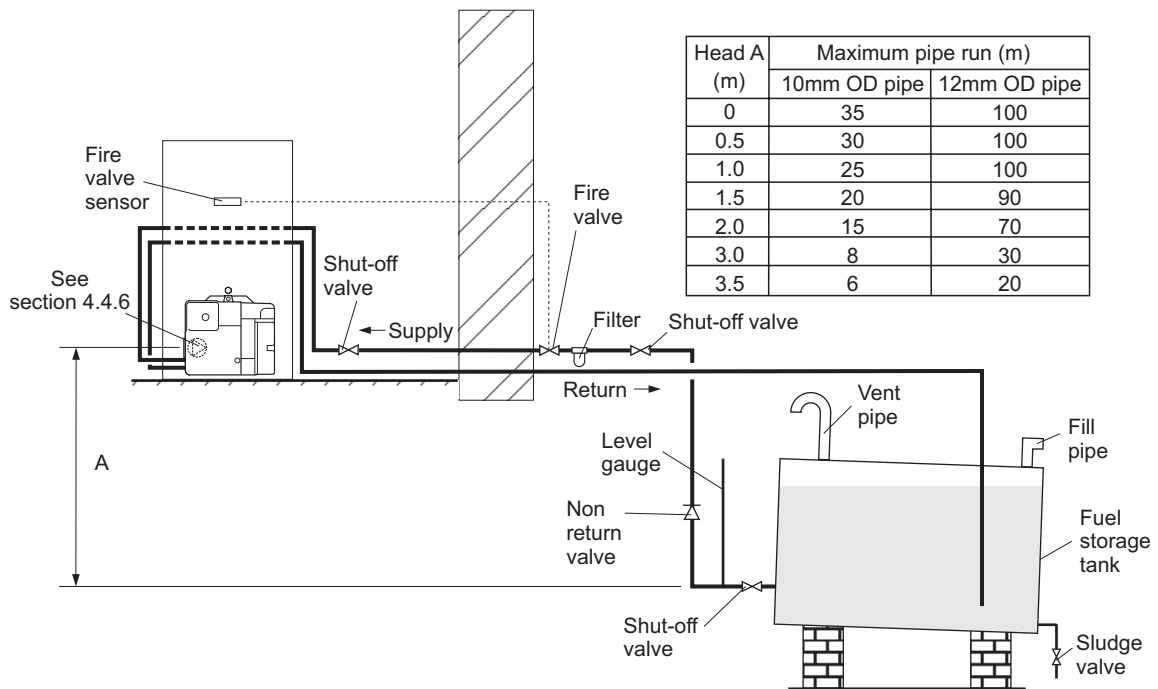

Fig. 4 - Two pipe system

4.4.5 Tiger Loop system - (See Figs. 5 and 6)

- 1 When The storage tank is below the burner, an alternative to a two pipe system can be achieved using a "Tiger Loop" type oil de-aerator. This effectively removes the air from the oil supply on a single pipe lift.
- 2 The de-aerator is connected close to the boiler as a two pipe system (omitting the non-return valve) as shown in Fig. 5. Refer to the manufacturers instructions supplied with the de-aerator. The de-aerator **must** be mounted vertically.

Note: To prevent any possibility of fuel fumes entering the building, the de-aerator **must** be fitted outside.

- 3 To be used with a de-aerator, the burner **must** be fitted with an additional flexible fuel hose (a flexible fuel hose (600 mm) and $\frac{3}{8}$ " to $\frac{1}{4}$ " BSP male adaptor are available to purchase from Grant Engineering (UK) Limited), Part No. RBS104. See Section 4.4.6.

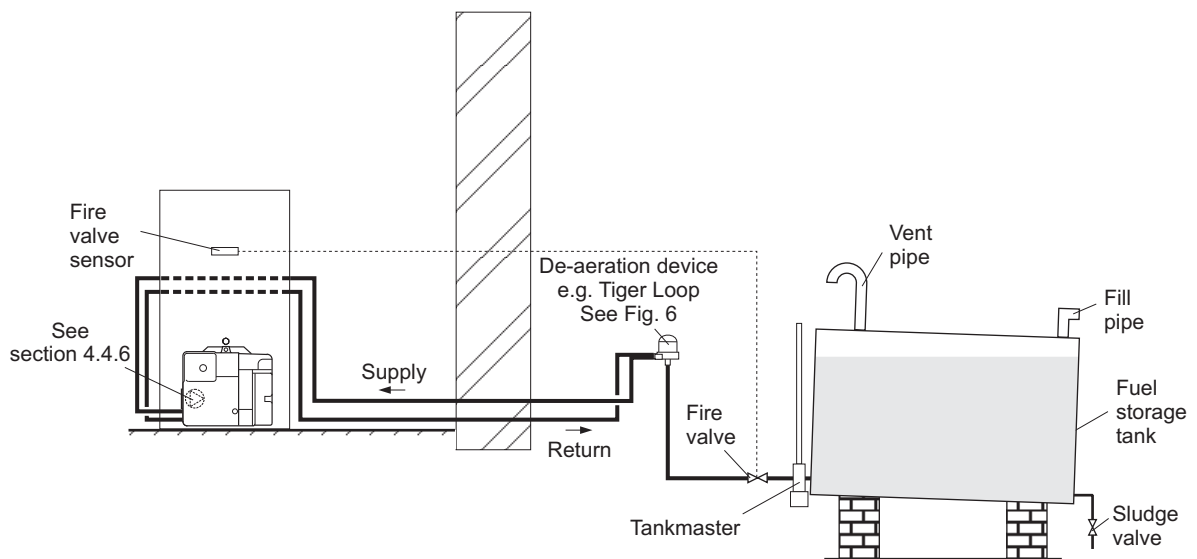

Fig. 5 - De-aeration device system

4 - GENERAL BOILER INFORMATION

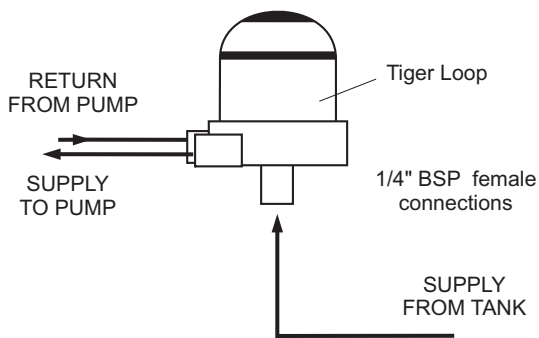

Fig. 6 - Tiger loop 'de-aeration' device

4.4.6 Two pipe oil supplies

Riello RDB burner - See Fig. 7

- 1 The fuel pump is supplied for use with a single pipe fuel supply system. For use on a two pipe system, it is necessary to fit the By-pass screw (see Fig. 7) into the tapping in the return port.
- 2 The By-pass screw is supplied in the boiler accessory pack.
- 3 Remove the plastic burner cover (secured by two screws). To gain access, it may be necessary to remove the plinth - loosen the screw securing the right hand side of the plinth, then withdraw the plinth forward from the right and away from the case.
- 4 Remove and discard the blanking plug from the return connection of the pump and fit the By-pass screw using an hexagonal key.
- 5 Connect the return oil flexible fuel hose to the pump.
- 6 Connect the $\frac{3}{8}$ " to $\frac{1}{4}$ " BSP adaptor to the flexible fuel hose.
- 7 Flexible fuel hoses and adaptors are available to purchase from Grant Engineering (UK) Ltd.

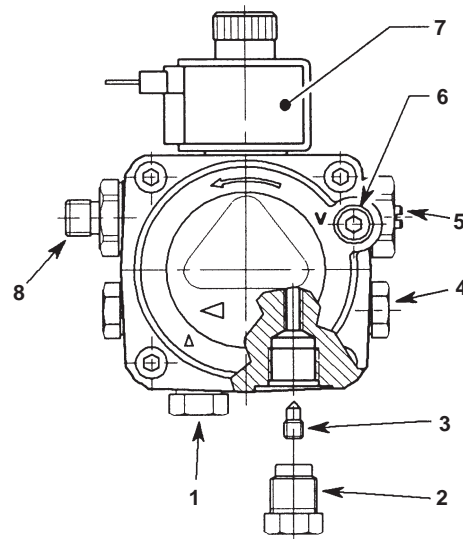

Fig. 7 - Riello RDB pump

- 1 Oil inlet connection
- 2 Return connection
- 3 By-pass screw
- 4 Pressure gauge connection
- 5 Pressure adjuster
- 6 Vacuum gauge connection
- 7 Solenoid
- 8 Supply to nozzle

4.5 Electricity supply

- 1 A 230/240 V ~ 50 Hz mains supply is required.

The boiler must be earthed.

- 2 The supply must be fused at 5 Amp and there must only be one common isolator for the boiler and control system, providing complete electrical isolation.
- 3 A fused double pole switch or a fused three pin plug and shuttered outlet socket should be used for the connection.
- 4 The power supply cable should be at least 0.75 mm² PVC as specified in BS 6500, Table 16.
- 5 All the wiring and supplementary earth bonding external to the boiler must be in accordance with the current I.E.E. Wiring Regulations.
- 6 Any room thermostat or frost thermostat used must be suitable for use on mains voltage.
- 7 In the event of an electrical fault after installation of the boiler, the following electrical system checks must be carried out:- Short circuit, Polarity, Earth continuity and Resistance to earth.

4 - GENERAL BOILER INFORMATION

BOILER IN ROOM

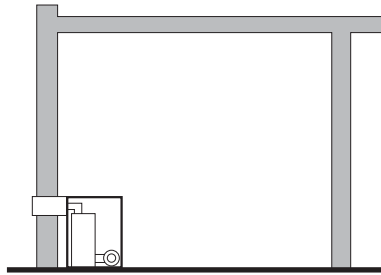

Room sealed balanced flue
no ventilation required to room

Output	15/21 kW	21/26 kW	26/35 kW
Vent A	116 cm ² (18 in ²)	143 cm ² (23 in ²)	198 cm ² (31 in ²)
Vent B	232 cm ² (36 in ²)	286 cm ² (46 in ²)	396 cm ² (62 in ²)

BOILER IN COMPARTMENT

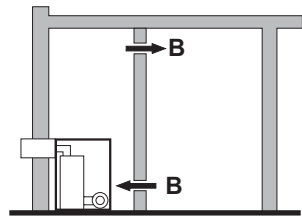

Room sealed balanced flue
compartment ventilated from room

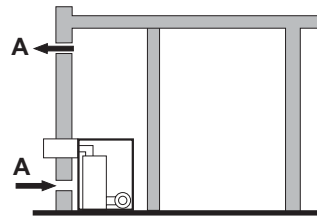

Room sealed balanced flue
compartment ventilated from outside

Fig. 8 - Air supply for room sealed balanced flue boilers

BOILER IN ROOM

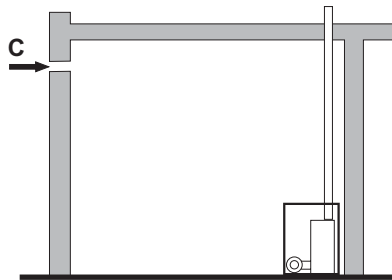

Conventional open flue

Output	15/21 kW	21/26 kW	26/35 kW
Vent C	116 cm ² (18 in ²)	143 cm ² (23 in ²)	198 cm ² (31 in ²)
Vent D	232 cm ² (36 in ²)	286 cm ² (46 in ²)	396 cm ² (62 in ²)
Vent E	348 cm ² (54 in ²)	429 cm ² (69 in ²)	594 cm ² (93 in ²)

BOILER IN COMPARTMENT

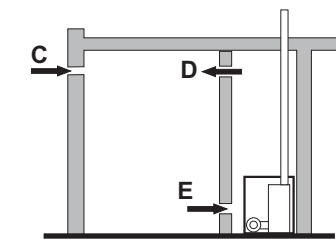

Conventional open flue
compartment ventilated from room

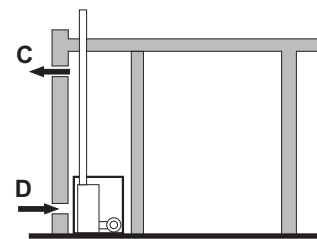

Conventional open flue
compartment ventilated from outside

Fig. 9 - Air supply for conventional flue boilers

4.6 Air supply

See Figs. 8 and 9

A sufficient permanent air supply to the boiler should be provided:

- a For proper combustion of fuel and effective discharge of combustion products to the open air.
- b For the ventilation of any confined space in which the boiler is installed to prevent overheating of the boiler any equipment in and near the boiler.

4 - GENERAL BOILER INFORMATION

It should be both the designer's and installer's concern that the air required for these functions be introduced so as to cause as little discomfort as possible to the building occupants and thus to offer them the least temptation to obstruct the ventilators.

Further details may be obtained from BS 5410:1:1997.

Notes:

For a boiler fitted in a compartment, which is ventilated as shown, no additional allowance is necessary.

Open flue - Extract fans, where needed, should be in accordance with Section 4.4.7 in BS 5410 Part 1 1997.

All ventilation areas given are for domestic applications. For all other cases refer to BS 5410 Part 2 1978.

4.7 Conventional flue system

Under no circumstances can Grant Vortex boilers be installed with existing flue systems. Only flue systems and components suitable for wet flues should be used.

Failure to install the correct type of flue system will invalidate the warranty.

See Fig. 10a and 10b

General

Grant condensing boilers have high operating efficiencies and low flue gas temperatures. Care must be taken to ensure the flue system is suitable for the very low flue gas temperatures and condensate in the flue gases.

Suitable conventional flue systems (Orange system) are available from Grant UK - see Fig. 10a.

- 1 The flue must terminate in a down draught free area, i.e. at least 600 mm above the point of exit through the roof or preferably above the ridge level.
- 2 The condensate may be allowed to run back into the boiler. A condensate drain at the base of the flue system is not required.
- 3 The flue terminal must be at least 600 mm from any opening into the building, and 600 mm above any vertical structure or wall less than a horizontal distance of 750 mm from the terminal. See Fig. 11.

- 4 If an existing chimney is to be used, it must be lined with a smooth bore stainless steel liner suitable for use with oil fired condensing boilers. The top and bottom of the annular space must be sealed. The internal flue and liner diameter for all models must be 100 mm (4 in).

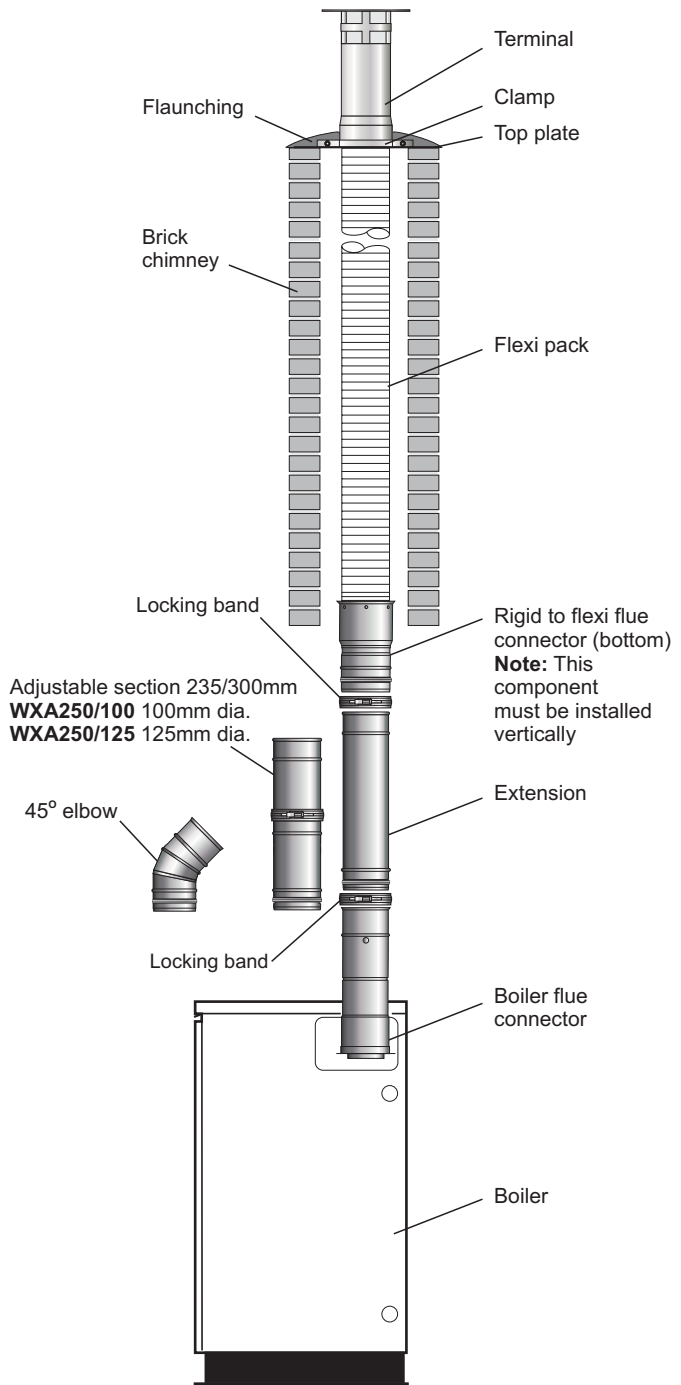

Fig. 10a - Grant Orange flue system in a typical brick chimney

Grant recommends the use of the Grant 'Orange' flue system, specifically designed for the Vortex range of condensing boilers. Refer to Section 4.7 for further details.

The **maximum** vertical height (from the top of the boiler to the terminal) for the 'Orange' system is **19 metres**.

4 - GENERAL BOILER INFORMATION

- 5 **If a rigid flue is used** internally or externally, it must be of the twin-wall type incorporating seals at all joints, constructed with a stainless steel inner skin and be suitably insulated and weatherproofed. Grant recommends the use of the Grant 'Green' flue system components for this application. Refer to Section 4.1 for details. The internal flue diameter for a rigid flue for all models is 100 mm (4 in).

Note: As no flue adaptor is supplied with the boiler it will be necessary to purchase the Grant CF adaptor kit (Ref. CFA15/70) in order to correctly connect the 'Green' system flue components to the boiler.

If required, it is possible to use the white painted single-wall straight flue extensions, adjustable extensions and elbows from the Grant 'Orange' system for the **internal** section of the flue system, see Fig 10b. These components can be fitted between the boiler connector and flue adaptor. The flue adaptor, to which the external twin-wall 'Green' flue components are connected, can therefore be situated just before the flue system passes through the wall.

Note: Grant 'Orange' system single-wall flue components **must not** be used externally.

The maximum vertical height (from the top of the boiler to the terminal) for the 100 mm diameter 'Green' system twin-wall flue is 8 metres.

- 6 Twin-wall flues are recommended for externally run flues to reduce the possibility of the condensate freezing in the flue.
- 7 No part of any flue system should be made of an asbestos material; aluminium must not be used in any part of the flue. Only stainless steel flue components should be used.
- 8 If the draught conditions are satisfactory, the flue should terminate with a standard cowl.
- 9 Refer to the locally applicable Building Regulations, BS 5410:1 and OFTEC Installation Requirements (Books 2 and 3) for further guidance on conventional flue systems.

It is important to ensure that the flue system is sealed and that condensate cannot escape. Up to 1.5 l/h of condensate can be produced in a conventional flue system.

Only use flue systems suitable for oil fired condensing boilers.

Do not use fire cement. The use of high temperature silicone sealants is recommended.

Grant EZ-Fit Flexi Pack conventional flue system (Orange System) - See Fig. 10a

A range of Flexi pack conventional flue lining kits are available from Grant UK. The packs have been specifically produced for Grant Vortex oil fired condensing boilers.

Contents of Grant EZ-Fit Flexi Pack

The pack includes a terminal/top plate/flexi flue adaptor, stainless steel smooth bore flexible flue liner, a rigid to flexi adaptor and a boiler flue connector.

Part No.	Flexi Pack (Orange System)
GFKIT 6/100	100 mm dia. x 6 metre
GFKIT 8/100	100 mm dia. x 8 metre
GFKIT 10/100	100 mm dia. x 10 metre
GFKIT 11/100	100 mm dia. x 11 metre
GFKIT 12/100	100 mm dia. x 12 metre
GFKIT 14/100	100 mm dia. x 14 metre
GFKIT 16/100	100 mm dia. x 16 metre

Extensions

A range of white powder coated single wall extensions are available to connect the boiler to the flexible liner. The external diameter of the extensions is 100 mm. Extensions are supplied with locking bands.

Part No.	Extensions (Orange System)
WX 150/100	100 mm dia. x 150 mm
WX 250/100	100 mm dia. x 250 mm
WX 450/100	100 mm dia. x 450 mm
WX 950/100	100 mm dia. x 950 mm

Flue extensions cannot be cut.

An adjustable extension and 45° elbow are also available. See Figs. 10a and 10b.

The rigid flue between the boiler and flexible flue liner should incorporate an adjustable section to allow inspection and cleaning of the flue system.

4 - GENERAL BOILER INFORMATION

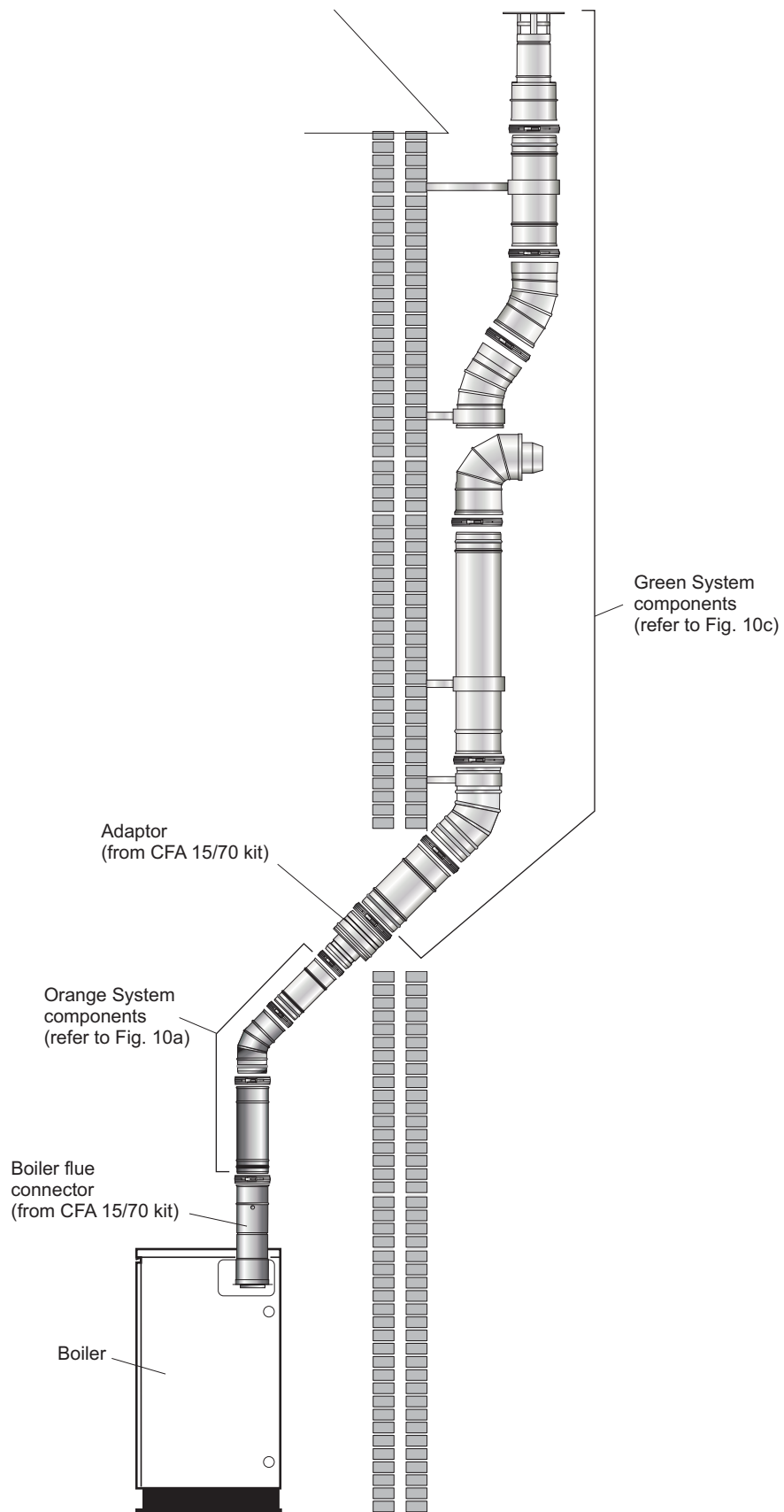

Fig. 10b - Hybrid flue system using Grant Orange and Green system components

4.8 *Balanced flue options*

Apart from a conventional flue, several balanced flue options are available for use with the Grant Vortex boilers. All are suitable for use with Class C2 kerosene.

Note: None of the flue sections in the following system can be cut.

1 **Low level horizontal balanced flue (Yellow system)**

Available in Short (for single thickness brick walls) and Standard kits.

Extensions are available which extend the flue by 225 mm, 450 mm or 675 mm. 90° and 45° elbows are also available.

The maximum flue length - from the centre of the boiler flue outlet to the outer face of the wall - is 4 metres (with or without elbows included). No more than 2 x 45° or 1 x 90° elbow should be fitted per system.

2 **High level (horizontal) balanced flue (White system)**

Allows the flue to rise vertically within the building before exiting through the wall horizontally.

The maximum flue length - from the top of the boiler flue outlet to the outer face of the wall - is 10 metres for all Vortex boilers.

Extensions are available which extend the flue by 225 mm, 450 mm or 950 mm. An adjustable extension of 275 to 450 mm is also available.

A 45° elbow is also available. No more than 6 x 45° elbows should be fitted per system. Each elbow reduces the overall maximum length of the system by 1 metre.

3 **Vertical balanced flue (White system)**

Allows the flue to rise vertically from the boiler to exit through the roof.

The maximum flue length - from the top of the boiler flue outlet to the terminal - is 12 metres for all Vortex boilers.

Extensions are available which extend the flue by 225 mm, 450 mm or 950 mm. An adjustable extension of 275 to 450 mm is also available.

A 45° elbow is also available. No more than 6 x 45° elbows should be fitted per system. Each elbow reduces the overall maximum length of the system by 1 metre.

4 **External balanced flue (Green system)**

Where it is not practical to use a low level (Yellow system) or internal high level/vertical (White system) balanced flue, the boiler can be fitted with an external vertical/high level flue (Green system). See Fig. 10c.

The Starter kit fits to the boiler in the same way as a low level balanced flue (Yellow system) and the external Tee allows the connection of a twin wall insulated flue pipe and a combustion air inlet - providing a room sealed flue system. The external system can terminate at either high level or vertically (above roof level) as required. See Fig. 10c.

The minimum dimensions for locating the terminal from building features (windows, doors, etc.) are shown in Fig. 11.

If the flue terminal is fitted less than 2 metres above a surface to which people have access, the terminal must be protected by a guard. The guard must be fitted centrally over the flue terminal and securely fixed to the wall.

The low level balanced flue (Yellow system) is supplied with a stainless steel guard. This must be fitted in all circumstances to prevent objects from entering the flue outlet.

The terminal must be positioned so as to avoid products of combustion accumulating in stagnant pockets around the buildings or entering into buildings. Care should be taken that the plume from condensed flue gases does not cause a nuisance.

The following external flue (Green system) components are available from Grant Engineering (UK) Limited.

4 - GENERAL BOILER INFORMATION

Green System components	
Item - for 15/21 and 21/26 models	Part No.
Starter kit - standard	GK90
Starter kit - short	GK90S
150 mm extension	GX150/90
250 mm extension	GX250/90
450 mm extension	GX450/90
950 mm extension	GX950/90
195-270 mm adjustable extension	GXA250/90
45° elbow	GE45/90
High level terminal	GTH90
Vertical terminal	GTV90
Wall bracket - standard	GWB90
Wall bracket - extended	GEB90

Green System components	
Item - for 26/35 model	Part No.
Starter kit - standard	GK200
Starter kit - short	GK200S
150 mm extension	GX150/200
250 mm extension	GX250/200
450 mm extension	GX450/200
950 mm extension	GX950/200
195-270 mm adjustable extension	GXA250/200
45° elbow	GE45/200
High level terminal	GTH200
Vertical terminal	GTV200
Wall bracket - standard	GWB200
Wall bracket - extended	GEB200

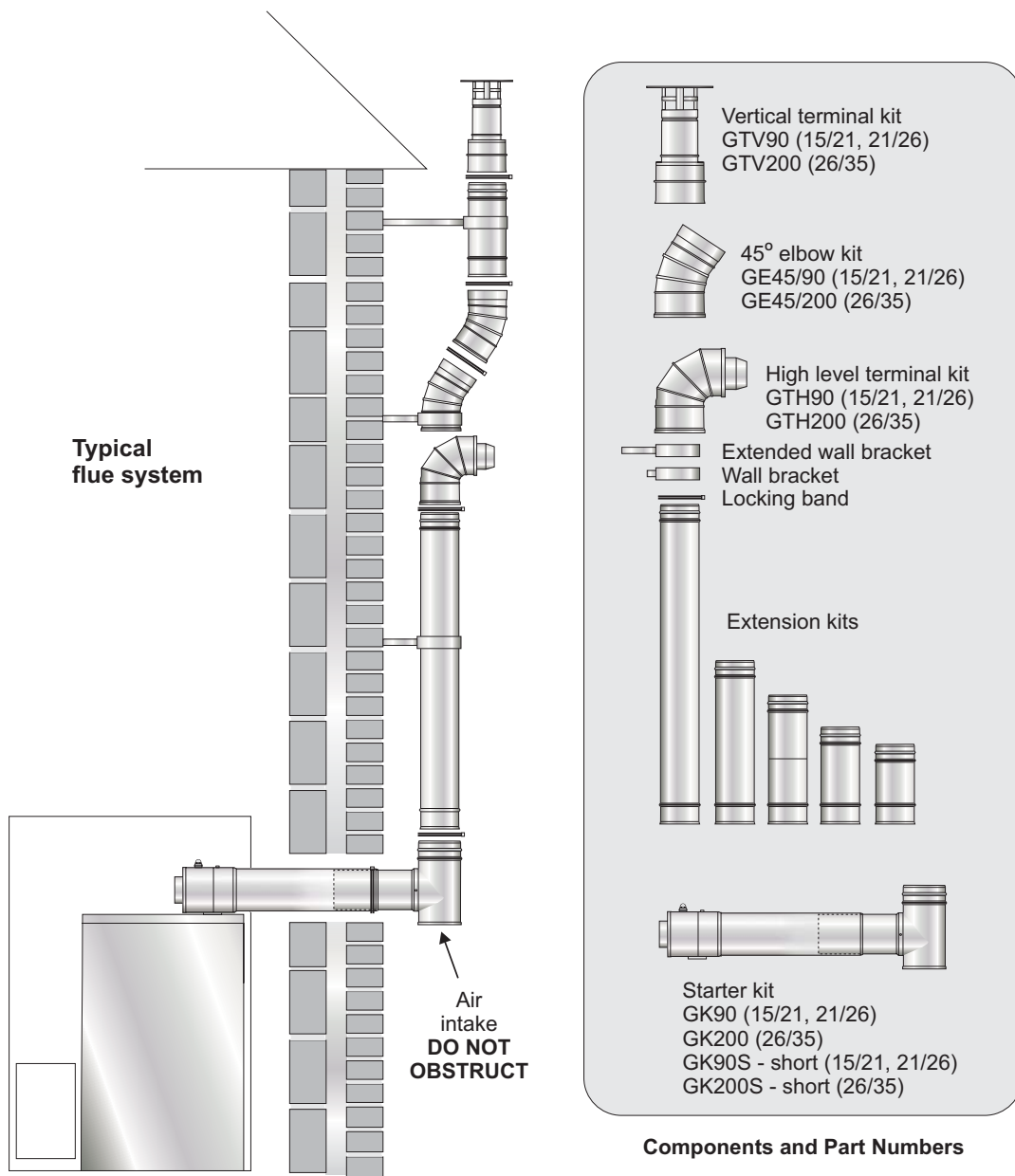

Fig. 10c - External balanced flue (Green system)

5. Flexible vertical balanced flue (Red system)

This is a flexible vertical balanced flue system (for the 15/21 and 15/26 models only) designed to be fitted inside an existing masonry chimney. See Fig. 10d. It basically consists of three sections:

- Concentric white painted flue pipe connected to the boiler
- Vertical concentric flexible flue (flexible stainless steel flue liner inside a flexible plastic air inlet liner)
- Terminal assembly for chimney top mounting

The flue pipe seals are factory fitted and **must be** lubricated with the lubricant supplied before assembly.

The Red system is supplied as a separate kit. Flue extensions and 45° elbows from the White system may be used to extend the flue between the boiler and the flexible section of the system.

The maximum vertical straight length of flue, from the top of the boiler to the top of the terminal, is 20 metres – using no more than **four** 45° elbows. Deduct 1 metre of straight flue length for every elbow used.

Note: If the flexible liners have to pass around an offset inside the chimney deduct 2 metres of straight flue length to compensate for this.

Flue extensions cannot be cut, use adjustable extensions where required.

Three types of locking band are supplied with the kit. The first type is painted white and is for connecting flue sections that butt together (2 of this type of locking band are supplied). The second type, also painted white, is to cover the joint on the adjustable (telescopic) section.

Note: The locking band for the adjustable section is labelled for easy identification.

The third locking band is plastic and supplied in two halves. This is to secure the plastic flexible liner to the adapter.

The flue kit includes a Black coated terminal with upstand and is designed to be fixed (using the screws provided) to the top of a masonry chimney.

The flue system may be offset using 45° elbows (ref. ELB K2145/90). No more than a maximum of **four** elbows should be used per system.

4 - GENERAL BOILER INFORMATION

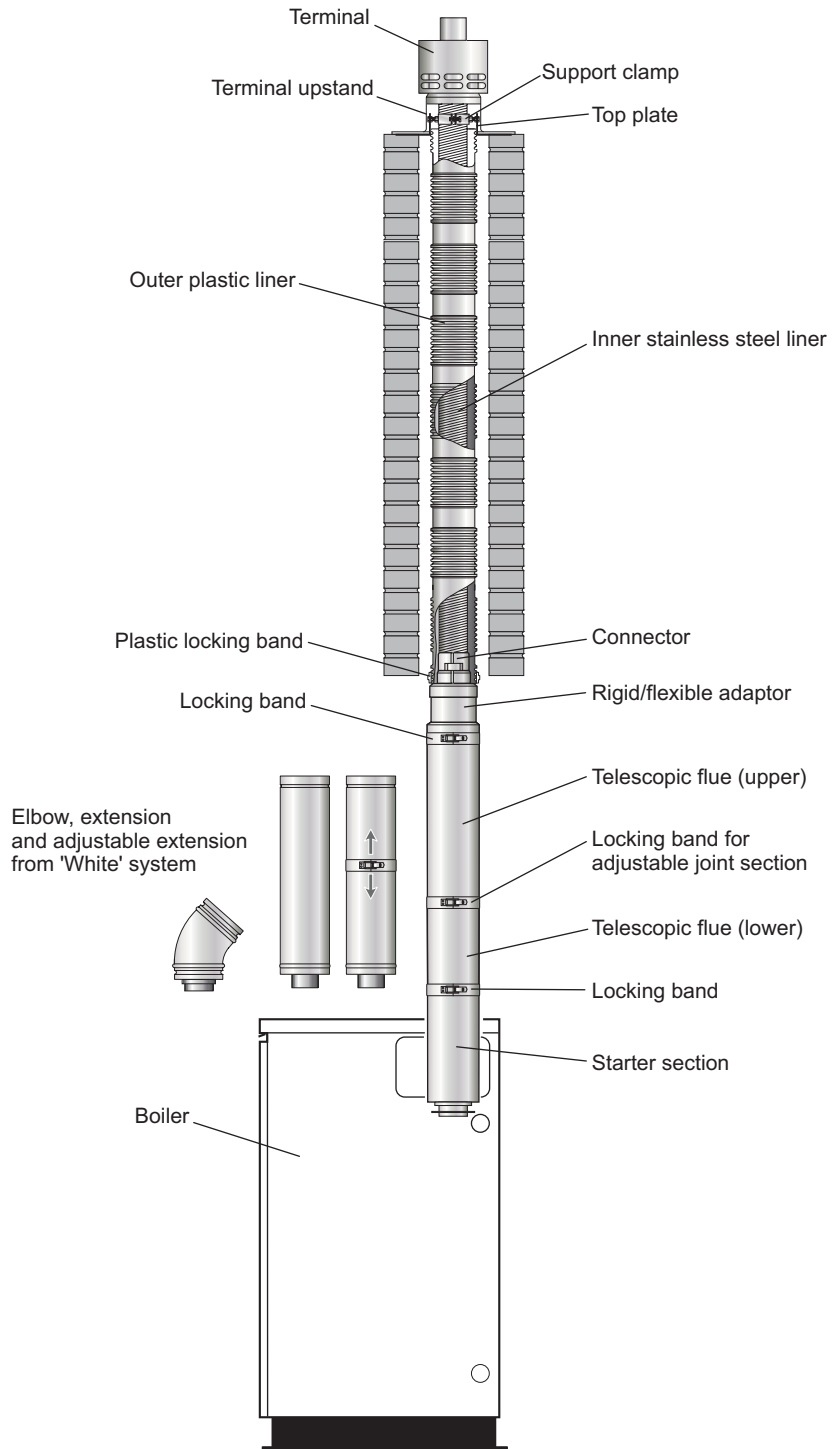

Fig. 10d - Flexible vertical balanced flue (Red system) 15/21 and 15/26 only

4 - GENERAL BOILER INFORMATION

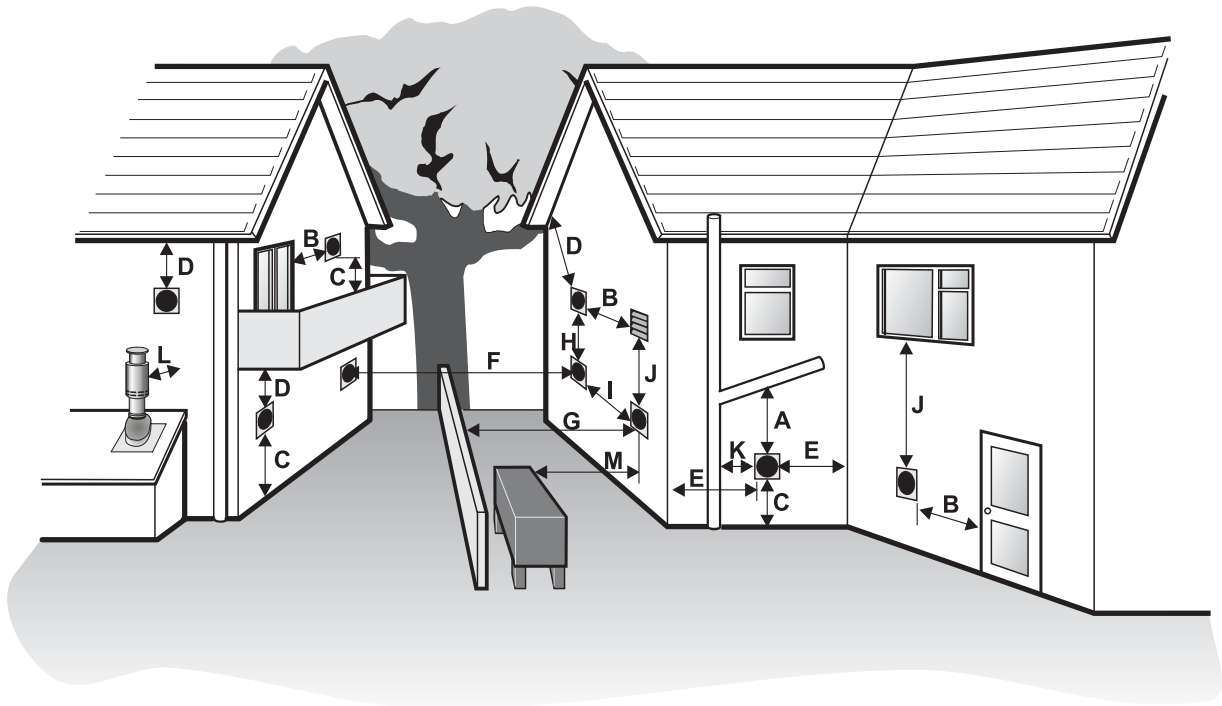

Fig. 11 - Clearances for Balanced flues

Terminal position	Min. distance (mm)
A Below a gutter or sanitary pipework	* 600
B Horizontal from an opening, air brick or window	600
C Above ground or balcony level	300
D Below eaves or balcony	*600
E From an internal or external corner	300
F From a terminal facing the terminal	1200
G From a surface facing the terminal	600
H Vertical from terminals on the same wall	1500
I Horizontal from terminals on the same wall	**750
J Below an opening, air brick, window etc.	600
K From vertical sanitary pipework	300
L Vertical flue from a wall	750
M From an oil storage tank	1800

Notes: * 75 mm with protection.

** Only applies if one or both terminals are balanced flues.

The Installer must ensure that the terminal does not cause a nuisance.

4.9 Frost protection

For additional protection of either the entire heating system, or the boiler and localised pipework, it is recommended that a frost thermostat be installed. Refer to Section 9 for connection details.

To protect the heating system, the frost thermostat should be sited within the house in such a place that it can detect any rise and fall in the ambient air temperature, i.e. in a room with a radiator.

Where the frost thermostat is installed outside the house (to protect a boiler installed in an external boiler room or garage) or in an attic, it is recommended that it be used in conjunction with a pipe thermostat to avoid unnecessary and wasteful overheating of the property. The pipe thermostat should be located on the boiler return pipe, and set to operate at 25° C. Refer to Section 9 for connection details.

Distances measured to rim of terminal.

Clearances recommended by Grant Engineering (UK) Limited in accordance with British Standards and Building Regulations.

- Notes:**
- 1 An opening means an openable element, such as an openable window, or a permanent opening such as a permanently open air vent.
 - 2 Notwithstanding the dimensions given, a terminal should be at least 300 mm from combustible material, e.g. a window frame.
 - 3 A way of providing protection of combustible material would be to fit a heat shield at least 750 mm wide.

4 - GENERAL BOILER INFORMATION

4.10 Boiler location

- 1 The boiler must stand on a surface that is firm and level. It does not require a special hearth as the temperature of the boiler base is less than 50° C.
- 2 Sufficient clearance **must be** allowed at the front of the boiler to remove the burner and baffles for servicing.
- 3 Once the boiler has been installed, a permanent worktop may be fitted over it as access to the top of the boiler is no longer required after installation.

Sealed system kit fitted - A removable section of worktop above the boiler is required to provide access for servicing.

4.11 Water connections - all models See Fig. 12

Boiler model	Flow connection			Return connection		
	Size	Fitting	Supplied	Size	Fitting	Supplied
15/21 Utility	22 mm pipe	Tectite straight	in fittings kit	22 mm pipe	Tectite straight	fitted
15/26 Utility	22 mm pipe	Tectite elbow	in fittings kit	22 mm pipe	Compression	fitted
26/35 Utility	28 mm pipe	Tectite straight	in fittings kit	28 mm pipe	Compression	fitted

A drain cock is fitted at the bottom on the front of the boiler to allow the heating system to be drained

IMPORTANT: All pipes to be fitted into the push-fit connectors provided should be cut using a pipe slicer or pipe cutter - to leave the pipe ends with a slight radius and free from any burrs or sharp edges. Pipes to be used with these fittings should not be cut square using a hacksaw.

All models

To avoid the danger of dirt and foreign matter entering the boiler the complete heating system should be thoroughly flushed out - before the boiler is connected and then again after the system has been heated and is still hot. This is especially important where the boiler is used on an old system.

For optimum performance after installation, this boiler and its associated central heating system must be flushed in accordance with the guidelines given in BS 7593:1992 'Treatment of water in domestic hot water central heating systems'.

This must involve the use of a proprietary cleaner, such as BetzDearborn's Sentinel X300 or X400, or Fernox Restorer. Full instructions are supplied with the products, but for immediate information, please contact BetzDearborn on 0151 4209563 or Fernox on 0179 9550811.

For Long term protection against corrosion and scale, after flushing, it is recommended that an inhibitor such as Betzdearborn's Sentinel X100 or Fernox MB-1 is dosed in accordance with the guidelines given in BS 7593:1992.

Failure to implement the guidelines will invalidate the warranty.

4 - GENERAL BOILER INFORMATION

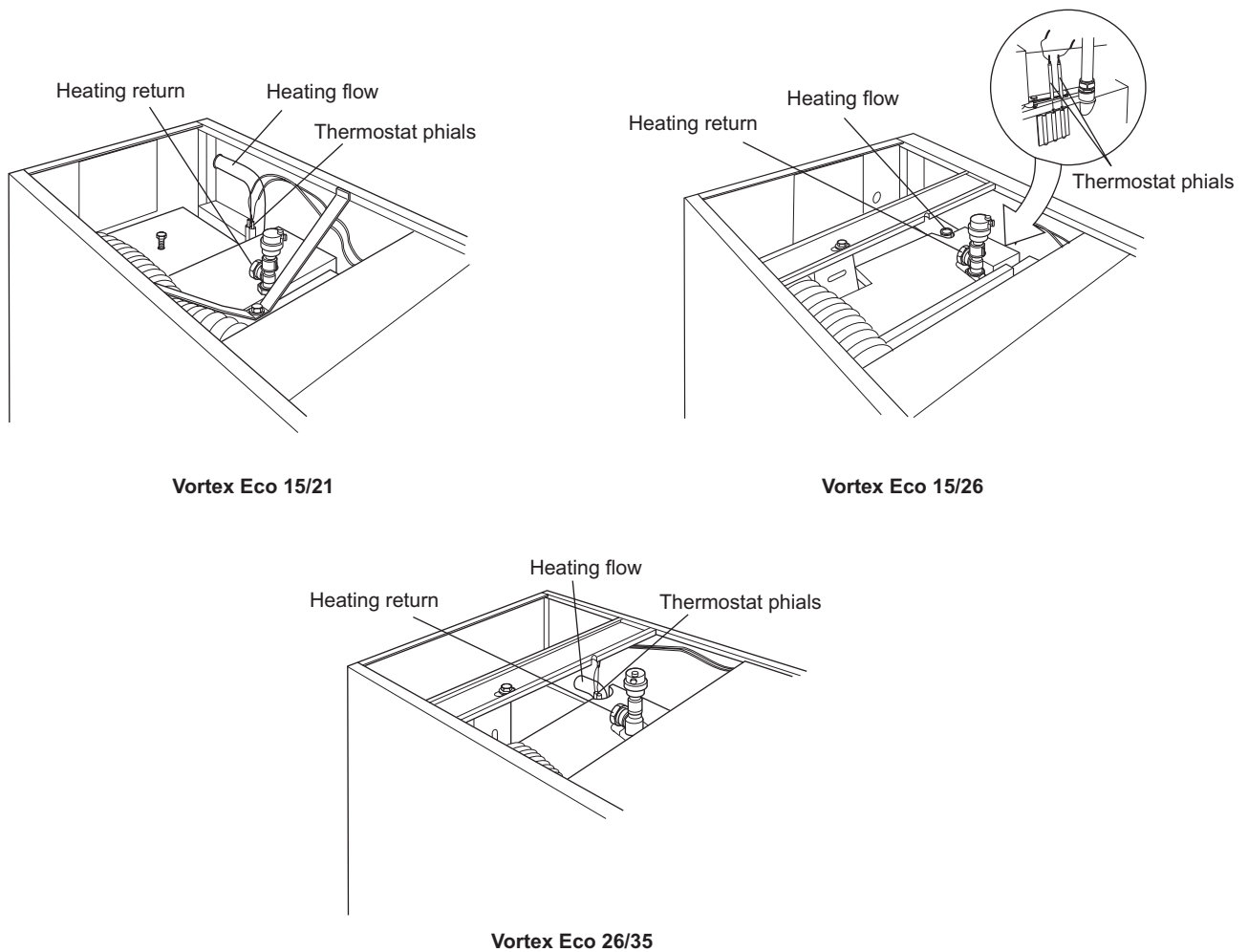

Fig. 12 - Water connections and thermostat phial positions

4.12 Sealed system kit

See Fig. 13

Grant sealed system kits, incorporating circulating pumps are available. See Section 6.6 and 6.7.

- 1 The boiler is only suitable for use with a sealed system complying with the requirements of BS 5449. The maximum temperature of the central heating water is 80°C.
- 2 The system must be provided with the following items:-
 - a Diaphragm expansion vessel complying with BS 4814.
 - b Pressure gauge.
 - c Safety valve.
 - d Approved method for filling the system. Refer to BS 7074:1 for further guidance.
- 3 The expansion vessel can be fitted in either the return or flow pipework in any of the recommended positions as shown in Fig. 12. To reduce the operating temperature of the expansion vessel diaphragm, position it below the pipe to which it is connected. The expansion vessel may be positioned away from the system, providing the connecting pipe is not less than 13 mm diameter.
- 4 The pressure gauge should have an operating range of 0 to 4 bar.
- 5 The safety valve, set to operate at 2.5 bar, should be fitted in the flow pipework near to the boiler. The pipework between the safety valve and boiler must be unrestricted, i.e. no valves. The safety valve should be connected to a discharge pipe which will allow the discharge to be seen, but cannot cause injury to persons or property.

4 - GENERAL BOILER INFORMATION

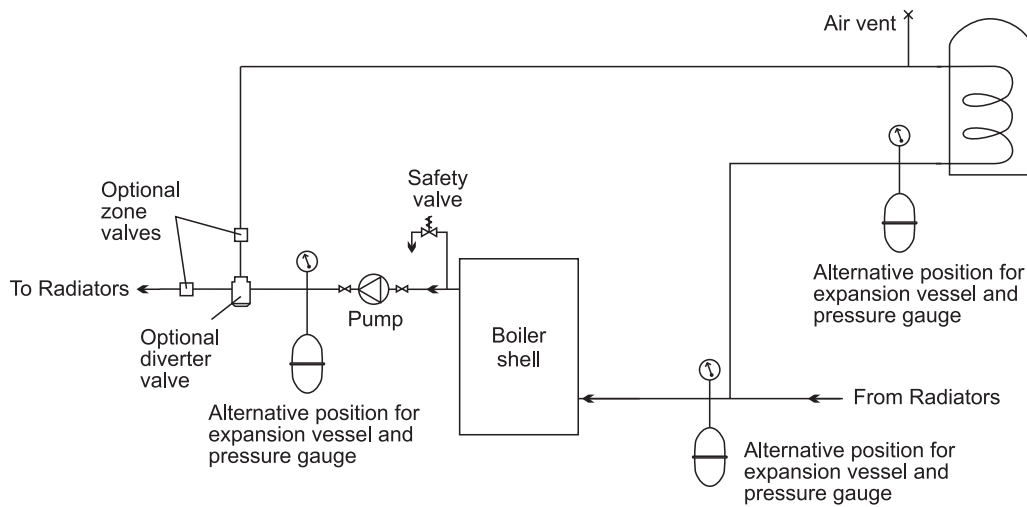

Fig. 13 - Sealed system

- 6 Provision should be made to replace water lost from the system. This can be done manually (where allowed by the local water undertaking) using an approved filling loop arrangement incorporating a double check valve assembly.
- 7 An automatic air vent should be fitted to the highest point of the system.
- 8 The system design pressure (cold) should be between 0.5 and 1.0 bar. This pressure is equivalent to the maximum static head in bar + 0.3 (1 bar = 10.2 metres of water).
- 9 All fittings used in the system must be able to withstand pressures up to 3 bar.
- 10 Radiator valves must comply with the requirements of BS 2767(10):1972.
- 11 One or more drain taps (to BS 2879) must be used to allow the system to be completely drained.
- 12 For proprietary expansion vessel/valve/gauge packs, refer to the manufacturers instructions for the correct location on the heating system.

4.13 Water connections - Sealed system kit

- 1 A 15 mm discharge pipe must be connected to the safety valve outlet connection. The pipework between the safety valve and the boiler must be unrestricted, i.e. no valves. The discharge pipe should be run to the outside of the building and terminate so that it cannot cause injury to persons or property.

- 2 A 15 mm double check valve ballcock type valve is provided on the flexible filling loop hose for connection of the cold mains supply to the heating system. The cold mains supply should terminate inside the boiler casing.
- 3 The expansion vessel is connected via a flexible hose to allow it to be moved to gain access to the baffle cleaning cover. When replacing the vessel, care should be taken to ensure that the flexible connecting hose is not twisted.

4.14 Underfloor heating systems

On underfloor systems it is essential that the return temperature **must be** maintained above 40° C to prevent internal corrosion of the boiler water jacket.

4.15 Pipework materials

General - Grant boilers are compatible with both copper and plastic pipe. Where plastic pipe is used it **must** be of the oxygen barrier type and be of the correct class (to BS 7291:Part 1:1990) for the application concerned.

IMPORTANT: The first metre of pipework connected to both the heating flow and return connections of the boiler **must** be made in copper on all types of system - sealed or open-vented.

Sealed systems - If plastic pipe is to be used, the installer must check with the plastic pipe manufacturer that the pipe to be used is suitable for the temperature and pressures concerned. Pipe must be Class S to BS 7291: Part 1:1990.

4 - GENERAL BOILER INFORMATION

The system should incorporate a low-pressure switch to shut off power to the boiler if the system pressure drops below 0.2 bar. A suitable low pressure switch kit is available to purchase from Grant Engineering (UK) Limited, Part No. MPCBS 62.

Underfloor systems - Plastic pipe may be used on Underfloor systems where the plastic pipe is fitted **after** the thermostatic mixing valve. Copper tube **must** be used for at least the first metre of flow and return primary pipework between the boiler and the underfloor mixing/blending valves.

5 - CONDENSATE DISPOSAL

5.1 General requirements

When in condensing mode the Grant Vortex Eco boilers produce condensate from the water vapour in the flue gases. This condensate is slightly acidic with a pH value of around 3 (similar to vinegar). Provision must be made for the safe and effective disposal of this condensate.

Condensate can be disposed of using one of the following methods of connection:

Internal connection (preferred option)

- into an internal domestic waste system (from kitchen sink, washing machine, etc.)
- directly into the soil stack

External connection

- into an external soil stack
- into an external drain or gully
- into a rainwater hopper (that is part of a combined system where sewer carries both rainwater and foul water)
- purpose made soakaway

All condensate disposal pipes **MUST** be fitted with a trap - whether they are connected internally or externally to a domestic waste system/soil stack or run externally to a gully, hopper or soakaway.

5.2 Connections

Connections into a rainwater hopper, external drain or gully should be terminated inside the hopper/drain/gully below the grid level but above the water level.

Condensate disposal pipes should not be connected directly into rainwater downpipes or to waste/soil systems connected to septic tanks.

Condensate should not be discharged into 'grey water' systems that re-use water used in the home (not including water from toilets).

It should be noted that connection of a condensate pipe to the drain may be subject to local Building Control requirements.

5.3 Pipework

Condensate disposal pipework must be plastic (plastic waste or overflow pipe is suitable).

IMPORTANT: Copper or steel pipe is **NOT** suitable and **MUST NOT** be used.

Condensate disposal pipes should have a minimum 'nominal' diameter of 22 mm (¾") - e.g. use 21.5 mm OD polypropylene overflow pipe.

Condensate disposal pipes must be fitted with a fall (away from the boiler) of at least 2.5° (~45 mm fall per metre run).

Note: Where it is not possible for the pipe to fall towards the point of discharge - either internally into a waste system or externally to a gully (e.g. for boilers installed in a basement), it will be necessary to use a condensate pump.

Condensate disposal pipes should be kept as short as possible and the number of bends kept to a minimum.

Pipes should be adequately fixed to prevent sagging, i.e. at no more than 0.5 metre intervals.

External pipework

Ideally, external pipework, or pipework in unheated areas, should be avoided. If unavoidable, external pipework should be kept as short as possible (less than 3 metres) and 32 mm waste pipe used to minimise the risk of ice blocking the pipe in freezing conditions.

The number of bends, fittings and joints on external pipes should be kept to a minimum to reduce the risk of trapping condensate.

Note: For boiler installed in an unheated area such as an outhouse or garage, all condensate pipework should be considered as an 'external'.

5.4 Condensate soakaway

To keep external pipework to a minimum, locate the soakaway as close as possible to the boiler but ensure it is at least 1 metre from building foundations and away from other services, e.g. gas, electricity, etc.

The condensate pipe may be run above or below ground level and can enter either the top or side of the soakaway tube. Refer to Fig.14.

Ensure that the drainage holes in the soakaway tube face away from the building.

Backfill both the soakaway tube, and the hole around it, with 10 mm limestone chippings.

Only use a soakaway where the soil is porous and drains easily. **Do not use in clay soils or where the soil is poorly drained.**

WARNING: Any damage due to condensate backing up into the boiler due to a high water table, in the case of a soakaway, or flooded drains when the condensate disposal is via a gully or soil stack, is not covered by the Grant product warranty.

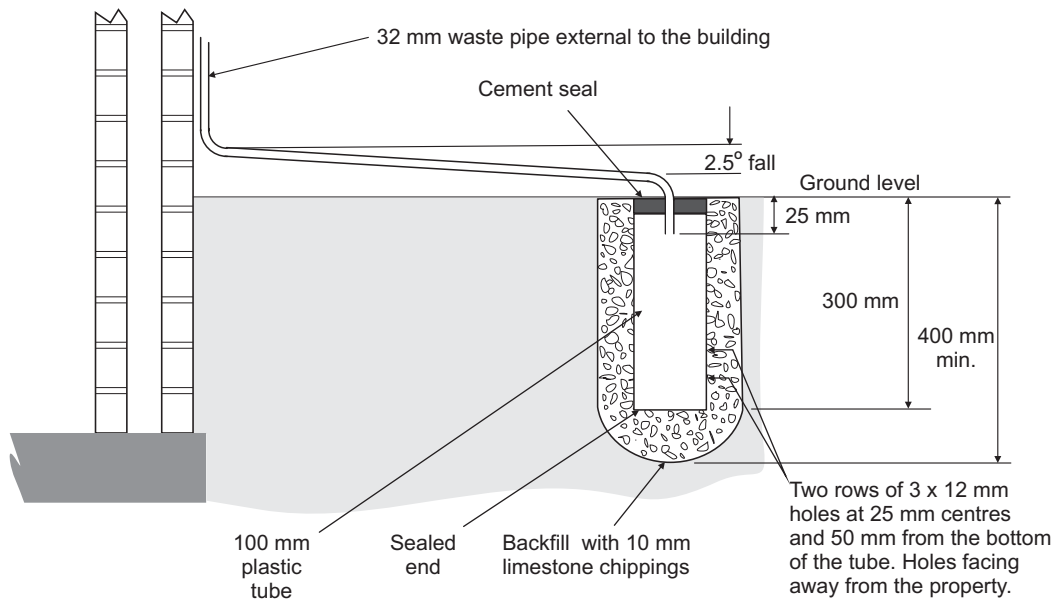

Fig. 14 - Purpose made condensate soakaway

5.5 Condensate trap

Grant Vortex Eco boilers are supplied with a factory-fitted condensate trap to provide the required 75 mm water seal in the condensate discharge pipe from the boiler.

This trap incorporates a float (which will create a seal when the trap is empty) and an overflow warning outlet (fitted with a plastic sealing cap), See Fig. 15.

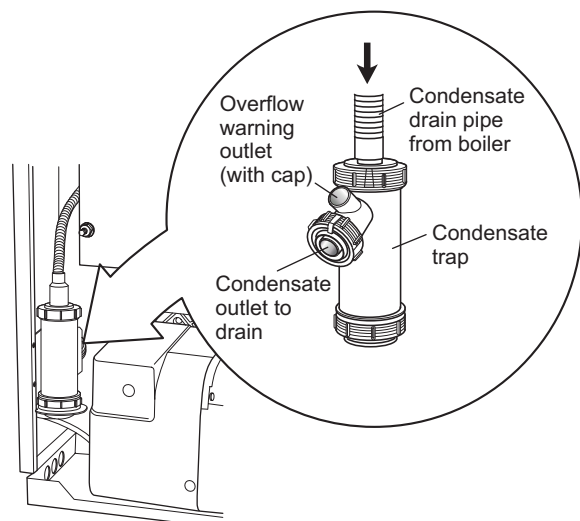

Fig. 15 - Condensate trap

The trap is factory-fitted inside the boiler casing (mounted on the inside of the left side panel) in an accessible position to allow for routine maintenance.

Note: If required, this condensate trap may be re-located outside the boiler casing. Refer to procedure given in 'external condensate trap'. This procedure **MUST** be carried out before the boiler is installed.

A flexible hose connects the outlet of the condensing heat exchanger to the trap inlet. Ensure the straight connector on the hose is fully pushed onto the 'top hat' inlet connector of the trap.

With the trap fitted inside the boiler casing, the sealing cap **MUST** be fitted. If the trap is re-located outside the boiler then the following applies:

If connecting the condensate discharge (either internally or externally) into a waste system or soil stack - the sealing cap **MUST** be fitted in the trap outlet.

On external discharge systems to a hopper, gully or soakaway, the sealing cap should be removed from the trap outlet.

If there is any discharge of condensate from the overflow outlet, this could indicate a blockage (possibly due to freezing). Turn off the boiler and investigate the cause. If necessary contact your service engineer for assistance.

Care should be taken when siting the trap such that the overflow outlet is readily visible and that any condensate overflowing from the outlet cannot cause either a hazard to persons or damage to surrounding property or equipment.

5.6 Condensate disposal pipework

The condensate trap outlet is at an angle of 48° below the horizontal. This is to automatically give a 3° fall on any 'horizontal' runs of condensate disposal pipe. Refer to Fig.15.

The outlet of the trap will accept 21.5 mm to 23 mm OD Polypropylene overflow pipe for the condensate discharge pipe.

This discharge pipe can exit through the left side of the boiler through one of two pre-cut 'knock-outs' in the lower part of the left casing panel (see to Fig. 1). Push out the 'knock-out' from the required hole taking care not to distort the side panel.

5.6 Inspection and cleaning of trap

The trap **MUST** be checked at regular intervals (e.g. on every annual service) and cleaned as necessary to ensure that it is clear and able to operate.

Note: The bottom bowl is sealed to the trap body and cannot be removed.

To inspect and clean the trap:

- 1 Disconnect flexible condensate hose from inlet connector.
- 2 Unscrew the inlet connection nut.
- 3 Remove the inlet connector and nut from trap.
- 4 Remove trap from bracket.
- 5 Remove float from trap – clean if necessary.
- 6 Inspect inside of trap and clean as necessary.
- 7 Re-assemble trap, re-fit to boiler and re-connect flexible hose. Ensure that hose is fully pushed onto the trap inlet connector.

IMPORTANT: Failure to regularly check and clean the condensate trap may result in damage to the boiler and will not be covered by the Product Warranty.

5.7 External condensate trap fitting

To re-locate the factory-fitted trap outside the boiler casing, use the following procedure:

Note: This procedure must be carried out before the boiler is installed.

- 1 Remove the top casing panel(s) from the boiler.
- 2 Unscrew and remove the screws fastening the left side panel to the rear casing panel of the boiler.
- 3 Carefully separate the left side and rear panels just enough to gain access to the condensate outlet on the left rear of the condensing heat exchanger (see Fig.16).
- 4 Push out pre-cut 'knock-out' from the condensate outlet hole in the rear of left side casing panel.
- 5 Remove the right angle end of the flexible condensate discharge hose from the outlet connection on the condensing heat exchanger.
- 6 From the front of boiler, remove the straight connector end of the flexible hose from the top of the condensate trap.
- 7 Reverse the flexible hose and pass the straight connector end through the new hole in the left hand casing panel. Push the straight connector firmly onto the condensate outlet connection of the condensing heat exchanger - push on at least 20 mm.

- 8 Refit the left hand casing panel to the rear panel using the reverse procedure, ensuring all fixing screws are used.
- 9 Remove the trap from the mounting bracket.
- 10 Unscrew and remove the trap mounting bracket from the left side panel.
- 11 Fix the trap mounting bracket to the wall adjacent to the boiler in the required position.

Note: The top of the trap must be below the condensate connection on the boiler.

- 12 Re-fit the trap to the mounting bracket.

The mounting bracket supplied with the trap **MUST** be used - the trap should **NOT** be supported by the condensate pipework only.

- 13 Connect the flexible condensate hose to the trap, pushing the right angle hose connector onto the trap inlet connection.

IMPORTANT: The flexible hose must fall continuously from the outlet to the top of the trap.

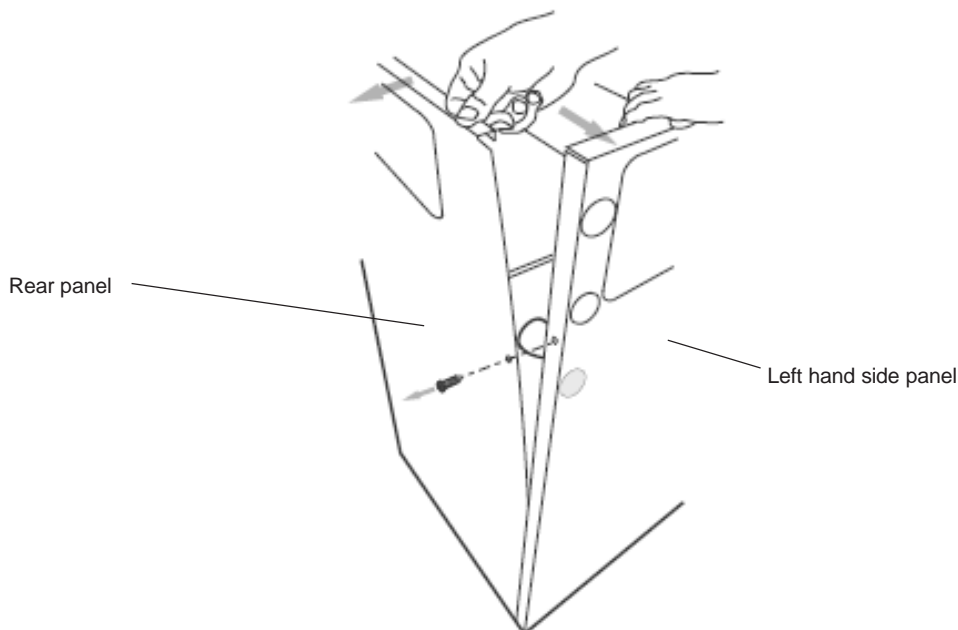

Fig. 16 - Remove the condensate trap

6 - BOILER INSTALLATION

6.1 Unpack the boiler

- 1 Carefully remove the packaging from the boiler and remove it from the transit pallet.
- 2 Pull the front panel forward at the top to disengage the fixing clips then lift it up and off the boiler. Remove the literature packs. Give the User Information pack to the householder.
- 3 Lift off the case top panel(s) and remove the water connecting fittings.

6.2 Prepare the wall

See Fig. 17 and 17a

If the boiler is to be used with a low level balanced flue (Yellow system) make the hole in the wall for the flue as shown in Fig. 17.

Note: Dimension B given in Fig. 17a includes an extra 10 mm over the size of the terminal to provide clearance for fitting.

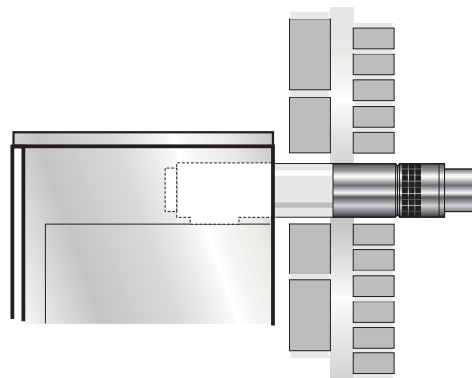

Fig. 17 - Low level balanced flue

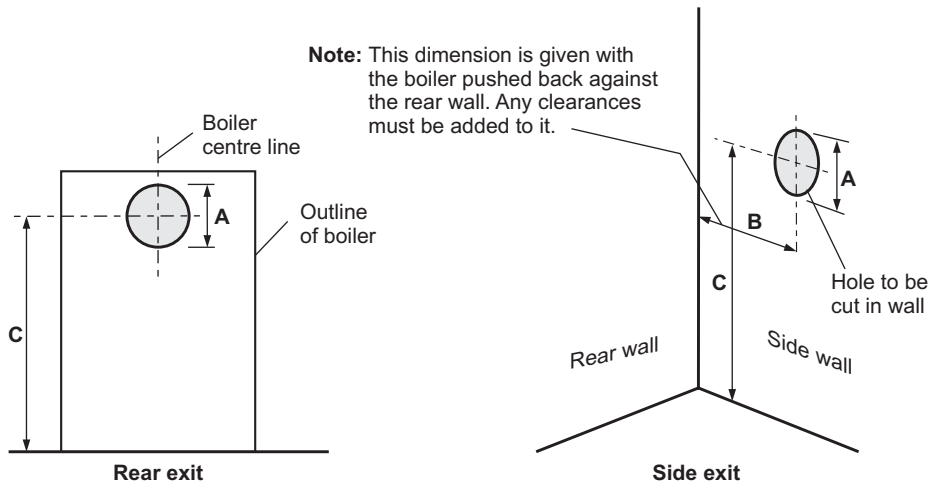

Fig. 17a - Low level balanced flue (Yellow System) and Starter kit (Green System)

Model	Dimension (mm)		
	A dia	B	C
15/21 and 15/26	127	115	768
26/35	162	115	780

6.3 High level and vertical balanced flue

See Fig. 18 and 18a

If the boiler is to be used with the high level balanced flue (White system) make the hole in the wall as shown in Fig. 18a.

Note: Dimension B given in Fig. 18a includes an extra 10 mm over the size of the terminal to provide clearance for fitting.

Fitting instructions for the high level balanced flue and vertical balanced flue are supplied with the flue kits.

Adjustable sections: The adjustable extensions are telescopic. The wall terminal section is adjustable and is suitable for a wall thickness of 215 mm to 450 mm. Simply adjust to the required length using a twisting motion. The outer pipes **must** overlap by a minimum of 25 mm.

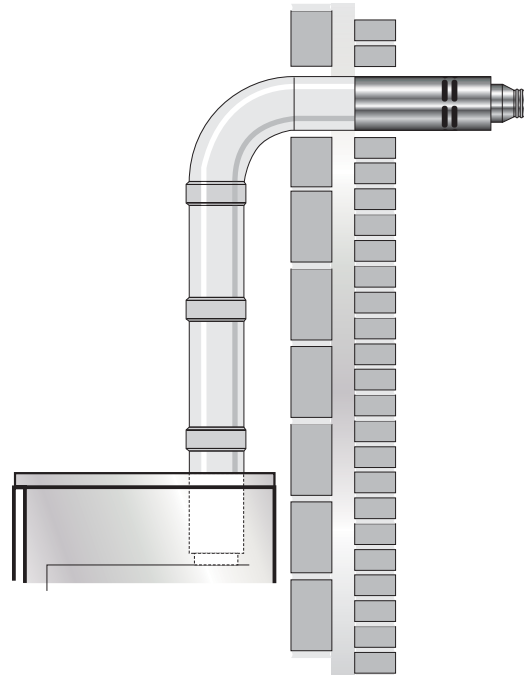

Fig. 18 - High level balanced flue

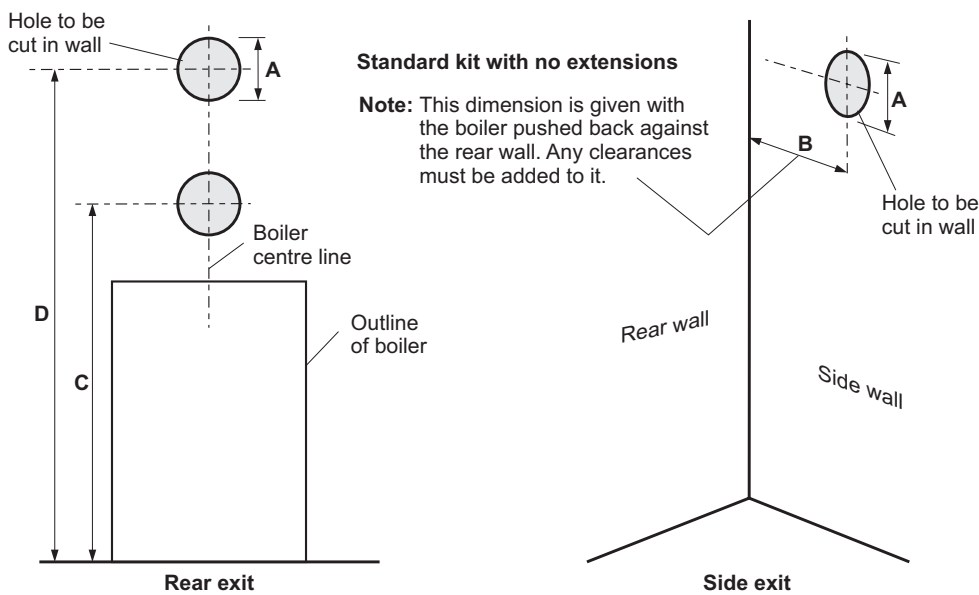

Fig. 18a - High level balanced flue (White system)

Model	Dimension (mm)			
	A dia	B	C	D
15/21 and 15/26	175	115	1215*	1715 - 2115
26/35	200	115	1280*	1700 - 2020

*Dimension C for Starter section and elbow/terminal only

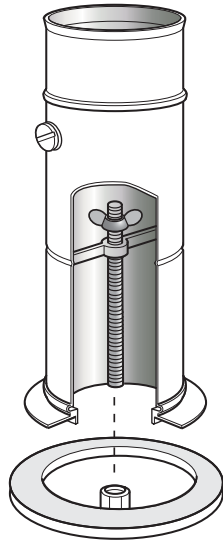

Fig. 19 - Boiler flue connector

6.4 Make the water connections

Refer to Section 4.11 and 4.12 and Fig. 12. for the size, type and position of the connections.

The Flow and Return pipework can be routed to either side of the boiler, dependant on the type and direction of the flue system used.

For condensate disposal pipework refer to Section 5.

IMPORTANT: All pipes to be fitted into the push-fit connectors provided should be cut using a pipe slicer or pipe cutter - to leave the pipe ends with a slight radius and free from any burrs or sharp edges. Pipes to be used with these fittings should not be cut square using a hacksaw.

Pipe entry/exit holes in case

All models have holes to enable the pipework to exit the boiler casing. On the 15/21 and 15/26 models these holes are pre-cut knock-outs located at the rear of both side panels and on the 26/35 model these pre-cut holes are in the removable flue outlet cover plates.

Push out the 'knock-out' from the required holes, taking care not to distort the side panel.

If access will be restricted, make any connections to the boiler before placing it in its final position.

If using a balanced flue system - Install the balanced flue system before connecting the heating system pipework to the boiler. Once the flue system is fitted then complete the water connections and fill the heating system.

If using a conventional flue system - Complete the water connections and fill the heating system.

Check all connections for leaks and rectify as necessary.

If the Grant sealed system kit is fitted, refer to Section 6.6 for details on filling and venting the sealed heating system.

6.5 Connect a conventional flue

1. Lift off upper rear casing panel.
2. Remove the insulation from the underside of the panel (do not discard it). Carefully press out the pre-cut flue opening in the top panel.
3. Unscrew the protective covers from the studs on the flue dress panel supplied in the literature pack. Place the dress panel in position in the rear casing top panel and secure in place using the nuts and washers previously removed.
4. Re-fit the insulation to the panel with the foil surface facing outwards. With a sharp knife cut around the edge of the round opening in the dress plate to leave a round hole through the insulation for the flue.
5. If the Grant 'Orange' flue system is being used – follow the instructions supplied with the flue kit.
6. If the Grant 'Green' system (100 mm rigid twin-wall flue) is to be fitted to the boiler then the Grant CF adaptor kit (Ref. CFA15/70) must be used – refer to Section 4.1. To fit the adaptor kit, proceed as follows.
7. Fully screw the length of threaded studding (provided in the kit) into the nut located in the centre of the boiler flue outlet.
8. Fit the boiler connector (from the CF adaptor kit) over the threaded studding. Position flange on to the neoprene gasket around the boiler flue outlet, ensuring that small spigot on the base of the connector is located in the hole in the centre of the neoprene gasket and that end of studding passes through the hole in the of the spacer bracket. Fit washer and wing nut provided onto end of threaded studding and secure connector in position by tightening down on wing nut – as shown in Fig. 21.
9. Re-fit the rear top casing panel to the boiler – fitting it over the boiler connector.
10. Fit the flue adaptor (from the adaptor kit) into the boiler connector. Note lubricate the seal on the adaptor using the lubricant provided before attempting to fit the flue adaptor.
11. Fit the first section of flue into the flue adaptor and secure using the clamp band provided.
12. Assemble the remainder of the flue system as required, lubricating the seal on each component before fitting.

6.6 Sealed system kit - 15/21, 21/26 and 26/35

- 1 The kit includes the following items:
Pressure relief valve and automatic air vent assembly
22 mm push-fit elbow
12-litre expansion vessel with flexible hose and sealing washer
Filling loop kit - including pressure gauge mounted on shut-off valve
6 m head circulating pump with 22 mm gate type valves
15 mm copper pressure relief valve discharge pipe
½" BSP black iron Tee
Pump support bracket – with screw, nut & washer
- 2 Unscrew the burner securing nut and remove the burner from the boiler.
- 3 Remove the ½" BSP black iron plug from the front of the boiler waterway, using a 3/8" drive socket wrench.
- 4 Remove the compression nut and olive from the end of the filling loop shut-off valve. Fit the ½" BSP straight end of the shut-off valve into one side of the black iron tee, using a suitable thread sealant (not supplied).
- 5 Fit the male thread of the black iron Tee into the tapping on the front of the waterway using a suitable thread sealant. Tighten until Tee (and shut-off valve) is horizontal.
- 6 Connect the flexible expansion vessel hose to the remaining connection on the black iron Tee.
- 7 Position the 12-litre expansion vessel on the front of the boiler combustion door locating the vessel bracket into cut-out in the front of the combustion door.
Note: on 15/21 and 21/26 models press on the pre-cut section in the centre of the door to form the cut-out for the bracket.
- 8 Fit the ¾" BSP connection of the flexible expansion vessel hose to the vessel using the black rubber washer supplied and tighten the nut.
- 9 Fit the pump support bracket to the vertical plate on top of the boiler shell. Fasten in place using the screw, nut and washer provided.
- 10 Push the 22 mm push-fit elbow onto the boiler flow connection.
- 11 Push the automatic air vent/pressure relief valve assembly into the push-fit elbow.

- 12 Fit both 22 mm pump valves to the circulating pump using the sealing washers supplied.
- 13 Fit the pump assembly to the automatic air vent/pressure relief valve assembly ensuring that the pump shaft is horizontal, the pump motor is facing towards the front of the boiler and the body is resting on the pump support bracket. The flow arrow on the body of the pump must face in the direction of flow away from the boiler connection.
- 14 Fit the pressure relief valve discharge pipe to the pressure relief valve using the nut and olive supplied. Route the discharge pipe through the slot in the base of the right hand side panel. Push the panel insulation back to expose the slot.
- 15 The circulating pump may be wired into the boiler control panel if required. Refer to Section 10.
- 16 Re-fit the burner and tighten the fixing nut to secure.
- 17 The filling loop should be connected, via the double check valve, to a 15mm cold water supply pipe from the mains at a convenient position inside the boiler.

6.7 Sealed system expansion vessel pressure

The expansion vessel fitted, is supplied with a charge pressure of 1.0 bar (equivalent to a max. static head of 10.2 metres). The charge pressure must not be less than the actual static head at the point of connection. Do not pressurise the vessel above 1.5 bar.

The air pressure in the vessel must be checked annually.

The central heating system volume, using the expansion vessel as supplied, must not exceed the recommended volumes. If the system volume is greater, an extra expansion vessel (complying with BS 4841) must be fitted as close as possible to the central heating return connection on the boiler. The charge pressure of the extra vessel must be the same as the vessel fitted in the boiler. Refer to BS 7074:1 for further guidance.

The air charge pressure may be checked using a tyre pressure gauge on the expansion vessel Schraeder valve. The vessel may be re-pressurised using a suitable pump. When checking the air pressure the water in the heating system must be cold and the system pressure reduced to zero.

It is recommended that the boiler should be connected to a switched mains power supply from a programmer or control system. Refer to Sections 10 for typical control system wiring diagrams.

6.8 Connect the power supply

- 1 Lift off the boiler case top panel, if it has not already been removed.
- 2 Remove the top of the control panel and open the cable clamp. Route the supply cable through the hole in the rear panel (using the grommet supplied) up to the control panel, pass it through the cable clamp and connect to the boiler terminal block (refer to Section 10) as follows:-
Brown to live (terminal 1)
Blue to mains neutral (terminal 2)
Green/Yellow to mains earth (terminal 3)
Note: Ensure that the route and length of the cable is such that the boiler front cover plate can be easily removed without disconnecting the supply cable from the terminal block.
- 3 Secure the cable in the cable clamp.
- 4 Place the wiring cover in position over the terminal block, taking care not to trap any wires and secure in position with the two M4 screws provided.
- 5 Ensure that all external wiring is adequately supported.

Do not switch on the electricity supply at this stage.

6.9 Connect the fuel supply

See Fig. 7

If a two pipe system is to be used refer to Section 4.4.6.

- 1 Remove the oil inlet plug from the fuel pump and connect the elbow of the flexible fuel hose supplied with the boiler.
- 2 Connect the flexible fuel hose to the rigid supply using the adaptor supplied. The supply enters through one of the holes in the casing plinth.

6.10 Fill the sealed system

- 1 Automatic air vent(s) are fitted to the top of the boiler. Check that the small cap on the top of each air vent is screwed on fully, then unscrew it one complete turn - the cap remains in this position from now on.
- 2 If the flexible filling loop is used to fill the system, ensure it is connected and that the valve connecting it to the boiler is open and the valve at the front is closed. A valve is open when the operating lever is in line with the valve, and closed when it is at right angles to it.

- 3 Ensure that the mains cold water supply valve is open (operating lever in line with the valve), then turn on the mains cold water supply and gradually open the front valve on the filling loop until water is heard to flow.
- 4 Vent each radiator in turn, starting with the lowest one in the system, to remove air.
- 5 It is important that the pump is properly vented to avoid it running dry and damaging its bearings. To gain access to the pump for venting it is necessary to remove the control panel.
Loosen the four fixing screws securing the panel to the casing, push the panel towards the rear of the boiler and lower the control panel to expose the pump.
Remove the cap, then unscrew and remove the plug from the centre of the pump. Using a suitable screwdriver rotate the exposed spindle about one turn. Replace the plug and cap.
- 6 Check the operation of the safety valve by turning the head anticlockwise until it clicks. The click is the safety valve head lifting off its seat allowing water to escape from the system.
Check that this is actually happening.
- 7 Continue to fill the system until the pressure gauge indicates between 0.5 and 1.0 bar. Close the fill point valve and check the system for water soundness, rectifying where necessary. Water may be released from the system by manually operating the safety valve until the system design pressure is obtained.
- 8 The system design pressure (cold) should be between 0.5 bar and 1.0 bar. The pressure is equivalent to the maximum static head in bar + 0.3 (1 bar = 10.2 metres of water), where the static head is the vertical height from the centre of the expansion vessel to the highest point of the system.
- 9 Close the valves either side of the filling loop and disconnect the loop.

6 - BOILER INSTALLATION

6.11 Completion

Please ensure that the OFTEC CD/10 installation completion report (provided with the boiler) is completed in full.

Leave the top copy with the User. Retain the carbon copy.

Ensure that the User Information pack (supplied with the boiler) is handed over to the Householder.

6.12 Burner components

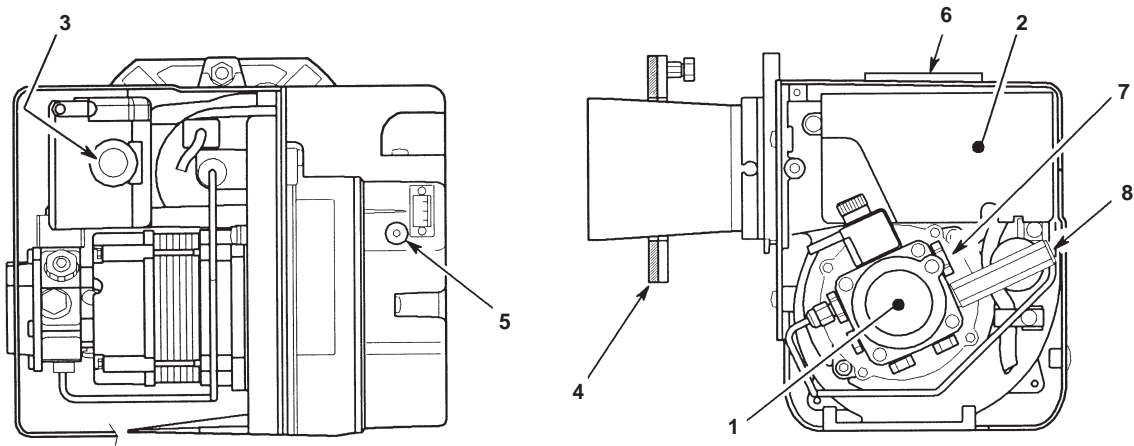

Fig. 20 - Riello RDB burner components

- | | |
|--|--|
| 1 Pump | 5 Air damper adjustment screw |
| 2 Control box | 6 Air supply tube connection (balanced flue) |
| 3 Reset button with lock-out lamp | 7 Pump pressure adjustment screw |
| 4 Flange with gasket (do not remove from boiler) | 8 Pressure gauge connection |

Refer to Fig. 21 for boiler controls

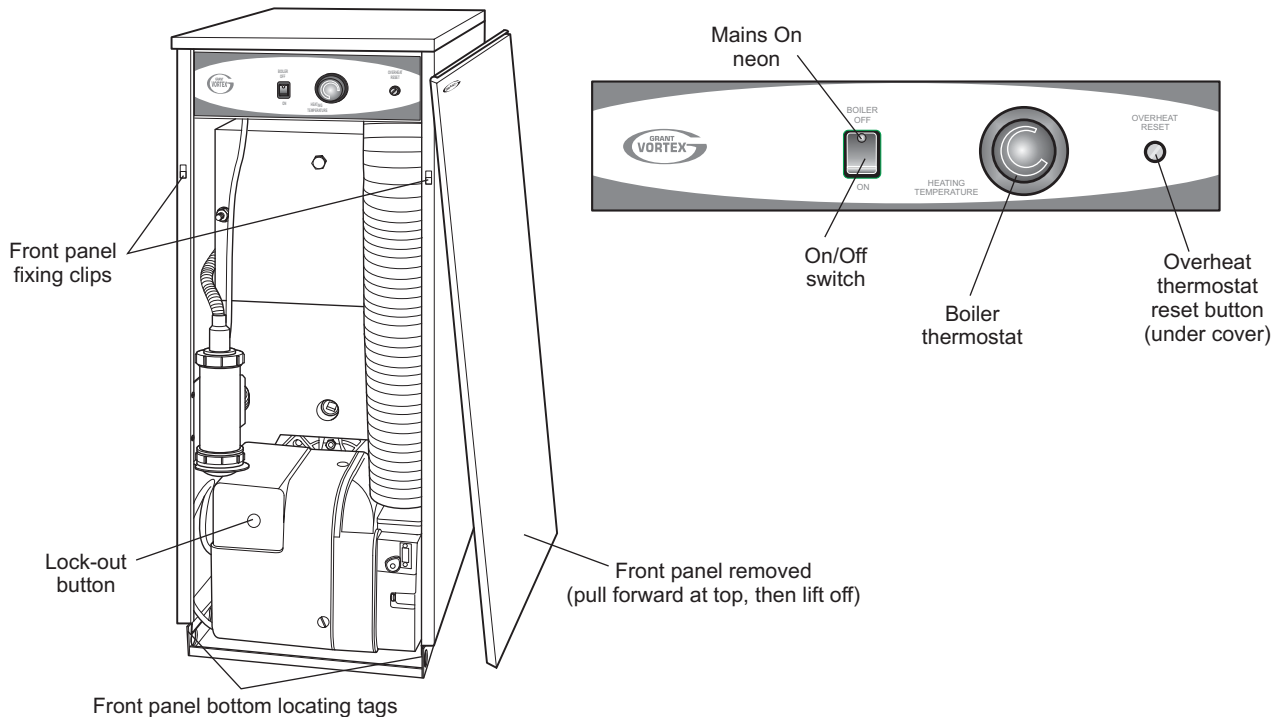

Fig. 21

It is important that the following commissioning procedure is carried out to ensure safe and efficient operation of the boiler.

Note: Check that the baffles are in position and that the cleaning cover is correctly fitted and a good seal made.

IMPORTANT:

Check that the turbulators are in position and that the ends are vertical (see Fig. 26).

Notes: 1. If the 15/21 model is down rated to 15 kW, the burner air adjuster disc must also be adjusted to setting B as described overleaf. See Section 3.3.

2. If the 15/26 models are down rated to 20 or 15 kW, the burner head must also be changed to a T1 head. See Section 3.3.

1 Check that the water system has been vented (and pressurised if sealed system) and there are no leaks.

Ensure the automatic air vent on the condensing heat exchanger is open.

2 Check that all fuel line valves are open.

3 Remove the plastic burner cover if it was not previously removed.

4 Connect a combined vent manifold and pressure gauge to the pressure gauge connection port on the oil pump. See Fig. 7. Open the vent screw on your vent manifold to vent the supply while the pump is running.

5 Set the boiler On/Off switch to Off. Check that all system controls are calling for heat and turn the boiler thermostat to maximum. Switch on the electricity supply.

6 Set the boiler On/Off switch to On. The burner fan should start and the burner should light within about 12 seconds. If the burner does not light and the 'Lock-out' reset button lights, wait for about 45 seconds then press the reset button to restart the ignition process. This procedure may have to be repeated several times during first lighting.

7 With the burner alight, check the fuel pressure. Refer to the Technical Information, Section 3.3. Adjust the pressure if necessary - see Fig. 7. Note that the 'Mains On' neon lights when the boiler is switched on, but does not necessarily indicate the burner is firing.

8 Operate the boiler until it reaches normal operating temperature. Check oil supply/return pipe for leaks, rectifying where necessary.

7 - COMMISSIONING

- 9 Check the operation of the boiler thermostat. Ensure that by turning it anticlockwise it switches the burner off.
 - 10 With the burner alight, re-check the fuel pressure and re-adjust if necessary. Turn the boiler off, remove the pressure gauge and replace the plug in the pump.
 - 11 Having ensured that there are no oil leaks, replace the burner cover. Ensure the flexible air tube is connected to the burner (balanced flue models).
 - 12 Relight the boiler and allow it to run for at least 20 minutes.
 - 13 Check the smoke number, if satisfactory check the CO₂. Set the CO₂ to the value given in Section 3.3 for the boiler concerned.
Use the hexagonal key supplied to adjust the burner air damper (see Fig. 20) as required. Turning the screw anti-clockwise closes the damper and increases CO₂ level, turning the screw clockwise opens the damper and reduces CO₂ level. Re-check the smoke number if the damper has been moved. Under no circumstances must the smoke number be above 1.
- Note: It is important that the air damper is correctly set.**
- 14 Check the flue gas temperature.
 - 15 Check that both the boiler overheat and boiler control thermostat bulbs are correctly located in their respective pockets. For location of thermostat pockets, refer to Fig. 12.
Also check the condition of both thermostat capillaries, i.e. that they are not damaged, broken or kinked, and that they are not trapped or crushed between any internal boiler components.
 - 16 Replace the case top.
 - 17 When the boiler has been adjusted and is running satisfactorily, balance the central heating system by adjusting the radiator lock shield valves. Start with the radiator nearest the boiler and adjust the valves to achieve the required temperature drop across each radiator. If thermostatic radiator valves have been installed, check the system by-pass.
 - 18 Switch off the boiler.
 - 19 With the system hot, check again for leaks, rectifying where necessary. Drain the system while it is hot to complete the flushing process. Refill and vent (and pressurise if a sealed system) the system.

20 A suitable central heating system inhibitor must be added to protect the system against the effect of corrosion.

- 21 Replace the front panel - Locate the bottom of the panel over the fixing tags then push it towards the boiler to engage the fixing clips.

Note: After commissioning the boiler complete the Commissioning Report on page 2 of these instructions and the OFTEC CD/11 commissioning report. Leave the top copy with the User and retain the carbon copy.

If the boiler is to be left in service with the User, set the system controls to the User's requirements.

If the boiler is not to be handed over immediately, close the boiler fuel supply valve and switch off the electricity supply.

If there is any possibility of the boiler being left during frost conditions, then the boiler and system should be drained.

IMPORTANT NOTE:

To allow the boiler to be commissioned and serviced correctly a combustion test point is provided on the front cleaning door.

The CO₂ and smoke test may all be carried out using this test point. The test point is not suitable for measuring boiler efficiency or conventional flue draught.

When using the test point on the cleaning cover note that the flue gas temperature reading will be higher than that measured in the flue thus resulting in an inaccurate efficiency reading. To obtain an accurate flue gas temperature and efficiency, the reading can only be measured outside through the low level flue terminal. For high level and vertical balanced flues the reading may be taken from the flue kit test point provided. Refer to Section 3.3.

For Conventional flue draught measurement and efficiency a test point is provided in the conventional flue adaptor.

To adjust the 15/21 air adjuster disc when downrating - See Fig. 22

1. Ensure the boiler is isolated from the electrical supply.
2. Disconnect the air supply tube.
3. Remove the burner from the boiler.
4. Undo the two screws and remove the air inlet cover from the side of the burner.
5. The secondary air shutter disc is factory set in position 'C' – i.e. with the cut-out marked C located against the die-cast boss on the fan housing - suitable for outputs of 18.3 and 21 kW only. See Fig 22.

7 - COMMISSIONING

6. Remove the screw from the centre of the air shutter disc, and re-position the disc such that the cut-out 'B' (corresponding to 15 kW output setting – See Section 3.3) is located against the cast boss on the fan housing. Replace the screw in the centre of the air shutter disc and tighten.
7. Re-fit the air inlet cover to the side of the burner and reassemble in reverse order.

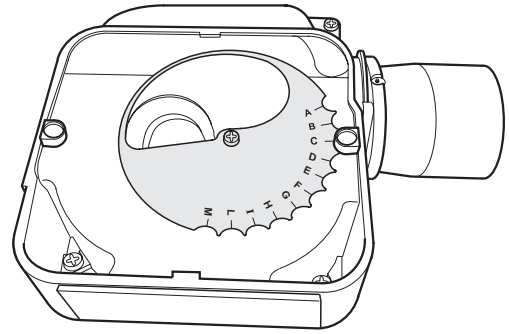

Fig. 22 - 15/21 air adjuster disc at position 'C'

8 - INFORMATION FOR THE USER

The User must be advised (and demonstrated if necessary) of the following important points:-

- 1 How to light and turn off the boiler and how to operate the system controls.
- 2 The precautions necessary to prevent damage to the central heating system and to the building, in the event of the boiler not being in operation during frost conditions.
- 3 The importance of servicing the boiler to ensure safe and efficient operation. This should normally only be required once a year.
- 4 The type of fuel used.
- 5 That any servicing or replacement of parts must only be carried out by a suitably qualified engineer.
- 6 Ensure that the boiler controls and room thermostat (if fitted) are set to the User's requirements.
- 7 If the boiler is used on a sealed heating system, tell the user the system pressure and show them the position of the safety valve discharge pipe.
- 8 Show the User how to reset the overheat thermostat and how to restart the boiler if it goes to 'Lock-out'.

Leave this Instruction manual with the User.

Ensure the User information pack is given to the Householder.

9 - BOILER SERVICING

To ensure efficient operation of the boiler it is recommended that it is checked and serviced as necessary at regular intervals. The frequency of servicing will depend upon the particular installation conditions and usage, but in general once per year should be adequate.

Servicing and replacement of parts must only be carried out by a suitably qualified engineer.

Important: Details of every service should be entered in the Service Log, in the Boiler Handbook. This information may be required to validate the Grant extended warranty.

IMPORTANT

Before starting any work on the boiler, or fuel supply please read the health and safety information given in Section 14 on page 47.

9.1 Important notes prior to servicing

- 1 Check the flue terminal and ensure it is not blocked or damaged.
- 2 Run the boiler and check the operation of its controls.
- 3 Ensure that all water/fuel system connections and fittings are sound. Remake any joints and check the tightness of any fittings that may be leaking.
If the boiler is used on a sealed central heating system, check the system pressure, check the operation of the pressure relief valve and check the expansion vessel air charge. See Section 6.6. Refill, vent and re-pressurise the system as necessary. See Section 6.11
- 4 Check that any ventilation openings are adequate and are clear. See Section 4.7.
- 5 Remove any sludge/water from the fuel tank by opening the sludge valve at the lower end of the tank.

9 - BOILER SERVICING

- 6 With the fuel supply valve closed, clean/replace the filter element and clean the filter bowl.
- 7 Flexible fuel supply hoses should be inspected annually when the boiler is serviced and braided hoses replaced every year. If in doubt replace the hoses

Warning: Before servicing, set the boiler On/Off switch to Off, isolate the electricity supply and close the fuel supply valve. Allow the boiler to cool. The data label on the inside of the case side panel will indicate the fuel used and the nozzle fitted.

9.2 Dismantling prior to servicing

- 1 Pull the front panel forward at the top to disengage the fixing clips then lift it up and off the boiler.
- 2 If a sealed system kit is fitted, carefully lift up and remove the expansion vessel from the front of the boiler. Place the vessel on the floor taking care not to strain the flexible pipe.
- 3 Disconnect the flexible air tube from the burner.
- 4 Remove the burner fixing nut (top of mounting flange) and withdraw the burner.
If required, disconnect the flexible oil hose(s), use a suitable container to prevent any oil spillage.

Note: If two flexible hoses are connected to the burner, identify (mark if necessary) which is the inlet and return if they are to be disconnected.

9.3 Cleaning the boiler

- 1 Remove the nuts and washers securing the front cleaning door and withdraw the door. Take care - it is heavy.
- 2 Remove the baffles as shown in Fig. 23.
- 3 Remove all deposits from the baffle plates and all the boiler internal surfaces using a stiff brush and scraper if necessary.
- 4 Check the condition of the flue, clean as necessary.
- 5 Check the condition of the front cleaning door seal, replace if necessary.
- 6 Replace the baffles, ensuring they are correctly fitted. See Fig. 23.
- 7 Pull out the spiral turbulators from the heat exchanger tubes. See Fig. 24.
Clean the turbulators using a stiff brush
Test the heat exchanger condensate drain by pouring water into one of the lower tubes and observe whether the water discharges from the 22 mm condensate outlet. Replace the turbulators.

- 8 Replace the front cleaning door, ensuring the seal is in good condition and secure it in position with the nuts and washers previously removed. Tighten to form a seal.
- 9 Remove the condensate trap and check that it is not blocked and is operating correctly, i.e. the float is free to move. Clean the trap and float as required.
- 10 Check that the boiler condensate outlet is unobstructed. Clean if necessary.

IMPORTANT: The condensate trap and condensate outlet must be checked on every service and cleaned as necessary.

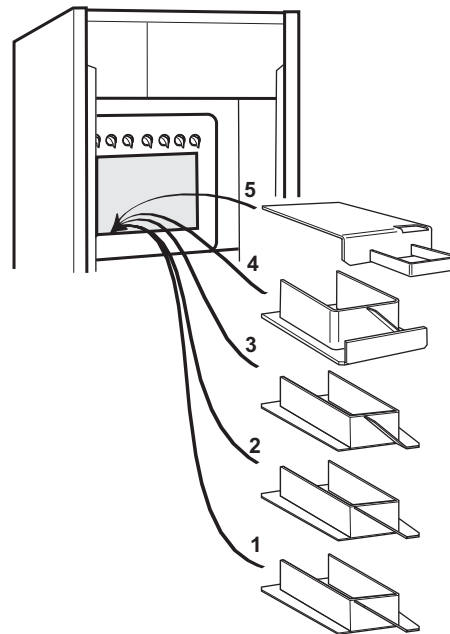

Fig. 23 - Baffles

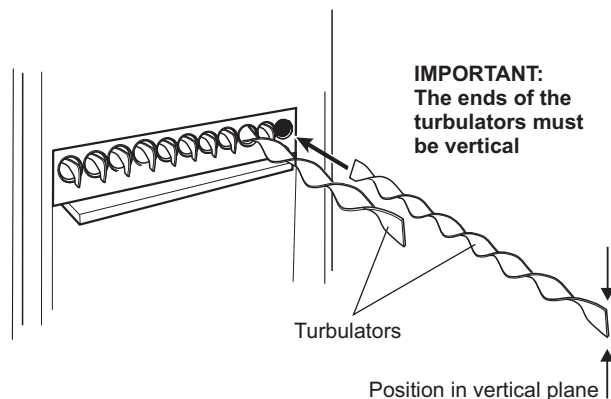

Fig. 24 - Turbulators

9.4 *Cleaning the burner*

See Section 13.1

- 1 **Combustion head** - Loosen the two screws securing the combustion head and withdraw the head. Clean and refit the combustion head.

- 2 **Inspect the ignition electrodes** - Remove the combustion head.

Loosen the electrode clamp screw and withdraw the electrode assembly. Wipe clean and check for any cracks in the ceramic insulation. Replace if necessary.

Check the electrode settings

Electrode tips approximately 4 mm apart and 3 to 3.5 mm in front of the nozzle, see Fig 25.

- 3 **Nozzle** - **The nozzle should be replaced on an annual service** - Check that the nozzle size and type are correct, refer to table in Section 3.3 and boiler data label.

With the combustion head removed, loosen the electrode assembly clamp screw and slide the electrodes away from the nozzle.

Do **NOT** attempt to clean the nozzle.

Remove the nozzle using a good fitting spanner (16 mm). The use of an ill-fitting spanner will damage the nozzle and could lead to an incorrect flame pattern. Always check the electrode settings after replacing the nozzle, see Fig. 25.

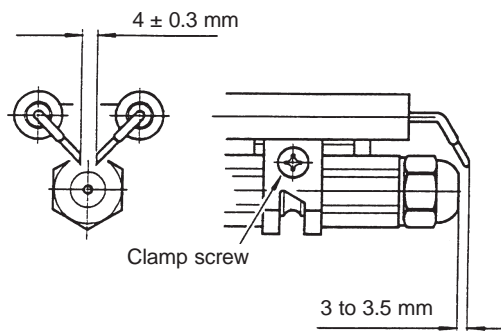

Fig. 25

IMPORTANT: The electrode settings given above MUST be observed

All models

- 1 **Photocell** - The photocell is a push-fit in the burner body. Carefully pull out the photocell to clean.
- 2 **Burner fan** - With the air intake grille or spigot removed, remove the screws securing the fan housing cover (R/H side of burner) and remove the cover. Inspect the fan and housing and clean as necessary. Replace the cover.
- 3 **Pump filter** - With the burner cover removed, remove the four screws securing the pump end cover. Remove the filter and wash in kerosene. Replace the filter and end cover, ensure the 'O' ring is in position.

Re-assemble in reverse order.

To ensure safe and efficient operation of the boiler it is important that re-commissioning is carried out, especially combustion checks (CO₂ level, flue gas temperature and smoke number) after the boiler has been serviced.

Refer to the Commissioning instructions starting on page 37.

10 - WIRING DIAGRAM

10.1 Control panel wiring diagram

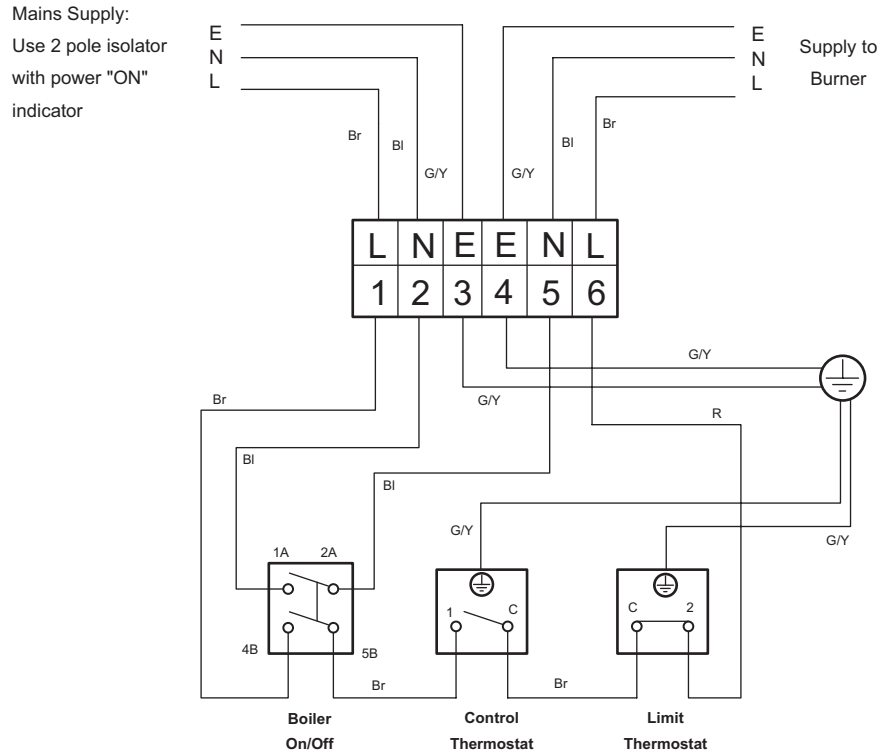

Colour code: Br - Brown, Bl - Blue, R - Red, G/Y - Green/Yellow

Fig. 26

11.1 Burner fault finding

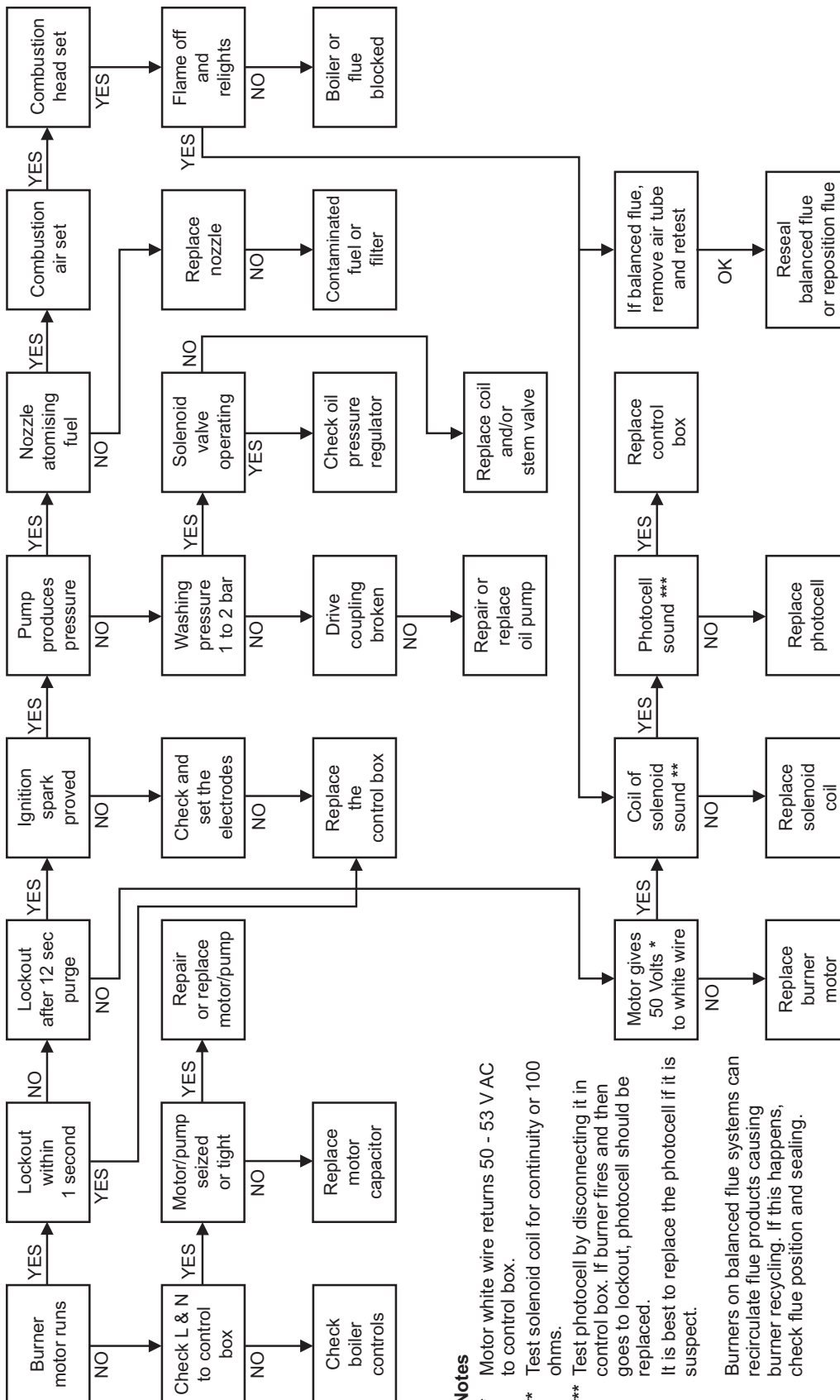

Notes

* Motor white wire returns 50 - 53 V AC to control box.

** Test solenoid coil for continuity or 100 ohms.

*** Test photocell by disconnecting it in control box. If burner fires and then goes to lockout, photocell should be replaced. It is best to replace the photocell if it is suspect.

Burners on balanced flue systems can recirculate flue products causing burner recycling. If this happens, check flue position and sealing.

11 - FAULT FINDING

11.2 Boiler fault finding

Warning: Always isolate the electricity supply to the boiler before working on the boiler.

Faults

Remedies

Boiler will not start

- | | |
|--|---|
| 1 No fuel supply. | Ensure that an adequate supply of fuel is available and that the fuel supply valve is open.
Check the condition of the fuel filter, clean if necessary.
Ensure fuel supply is reaching burner and vent pump. |
| 2 No electricity supply. | Ensure electricity supply to the boiler is switched on and that all controls are calling for heat.
Ensure that the overheat thermostat has not tripped, reset if necessary.
Check that a mains supply is present at the burner terminal block. If not, check the boiler and overheat thermostat. |
| 3 Burner not starting - fuel and electricity supplies present. | Press the reset button on the burner control box if it is lit.
Refer to burner fault finding flow diagram. |
| 4 Burner lights but goes to 'lock-out'. | If the flame is unstable, check the combustion settings.
Refer to burner fault finding flow diagram. |

Boiler works but:-

- | | |
|---|--|
| 5 Visible smoke from flue or high smoke number. | Insufficient air supply - check the air damper setting and the condition of the fan.
Check room ventilation is adequate, see Section 4.6.
Check the nozzle size and type.
Fuel pressure may be too high - check and adjust. |
| 6 Burner pulsates. | Insufficient air supply - check the air damper setting and the condition of the fan.
Check room ventilation is adequate, see Section 4.6.
Check the nozzle size and type. |
| 7 Flame slow to stabilise during start up. | Insufficient air supply - check the air damper setting and the condition of the fan.
Check room ventilation is adequate, see Section 4.6.
Check the nozzle size and type.
Fuel pressure may be too low - check and adjust.
Insufficient draught - clean boiler heat exchanger and check condition of flue. |
| 8 Water temperature low. | Undersize nozzle and/or low fuel pressure.
Check condition of boiler heat exchanger and clean if necessary.
Check the boiler thermostat.
Check the combustion settings.
Check the condition of the fuel filter. |
| 9 Boiler operating on overheat thermostat. | Faulty boiler thermostat. |
| 10 Fumes and puffing during starting (conventional flue). | Check the condition of the chimney, ensure it is not blocked and is high enough to produce the required draught.
Check that there is an adequate air supply near the burner and that a kitchen fan is not drawing products out of the burner. |
| 11 Oil odours. | Check all fuel line connections, remake as necessary. |
| 12 Combustion fumes smell. | Check boiler cleaning cover and seal are correctly fitted.
Check burner is correctly fitted onto flange.
Check flue is correctly sealed into flue outlet of boiler.
Check the condensate pipe and trap are operating correctly. |

12 - BOILER SPARE PARTS

12.1 Vortex Eco Utility - Spare Parts

Description	Part No.
Cleaning door nut and washer set	EFBS14
Double pole switch	EFBS19
Baffle set - 15/21	UBS93
Baffle set - 15/26	VBS12
Baffle set - 26/36 and 36/46	VBS13
Sealed system - Expansion vessel 10 litre - 15/21	MPCBS27
Sealed system - Expansion vessel 12 litre - 15/26	MPSS01
Sealed system - Expansion vessel 16 litre - 26/36 and 36/46	MPSS07
Sealed system - Water pressure gauge	MPSS02
Sealed system pressure relief valve	MPSS03
Sealed system - Expansion vessel flexible hose	MPSS04
Cleaning cover seal - 15/21	UBS15
Cleaning cover seal - 15/26	VBS15
Cleaning cover seal - 26/36 and 36/46	VBS16
Overheat thermostat	TPBS33
Boiler thermostat	TPBS34
Circulating pump - 6 m head	MPCBS23
Circulating pump - 7 m head	VBS54

Burner Heads

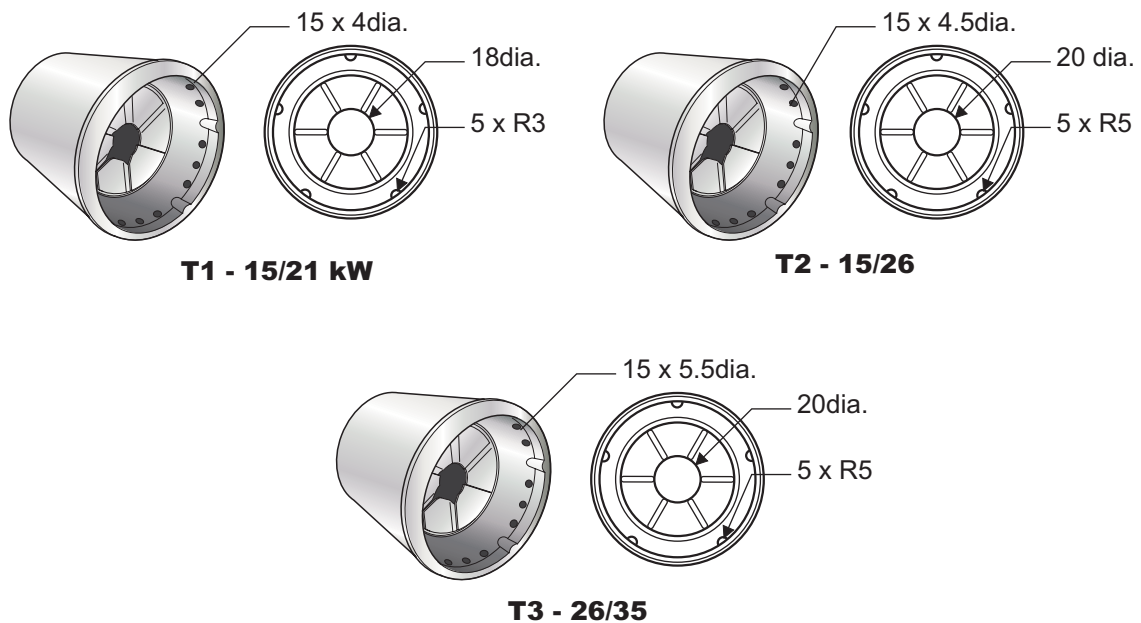

13 - BURNER SPARE PARTS

13.1 Riello RDB1, 2, 2.2 burner - exploded view

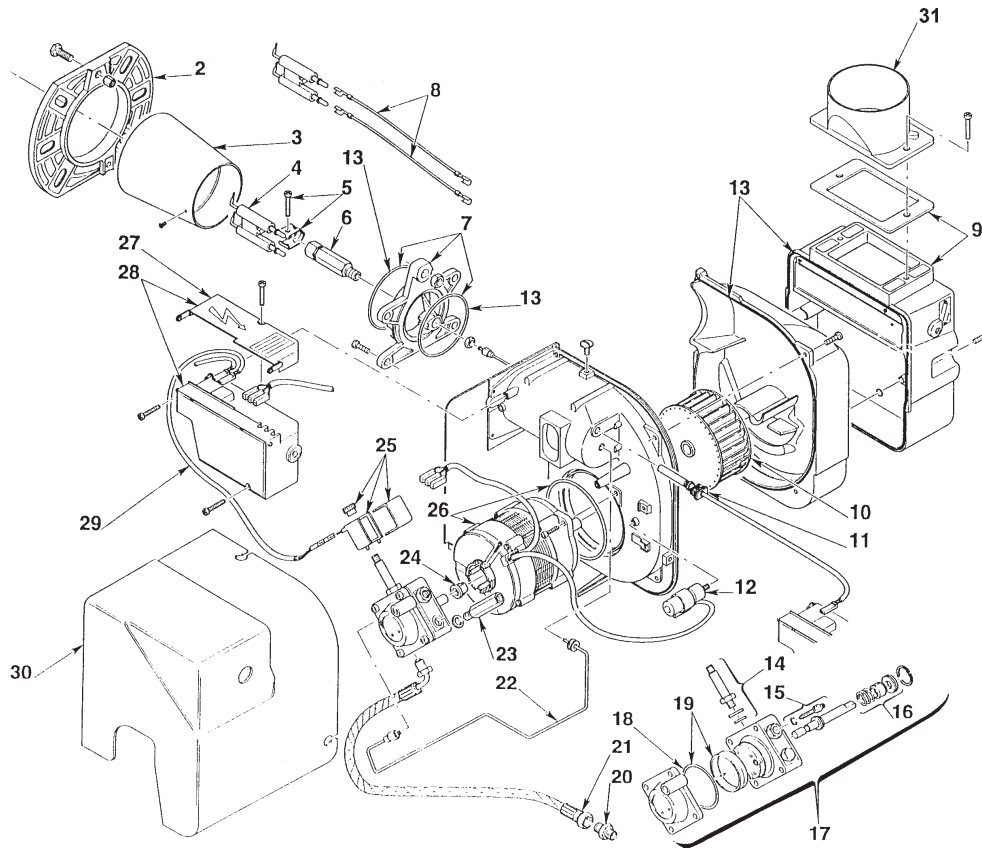

Key No.	Description	Riello Part No.	Grant Part No.	Key No.	Description	Riello Part No.	Grant Part No.
1	Not applicable	-	-	15	Regulator	3008651	RBS120
2	Flange	3005786	RBS119	16	Pump seal	3000439	RBS14
3	Combustion head T1 - 15/21 kW	3002507	RBS146	17	Pump	3008654	RBS101
3	Combustion head T2 - 15/26	3002423	RBS147	18	'O' ring	3007162	RBS08
3	Combustion head T3 - 26/35	3002447	RBS144	19	Filter - 'O' ring	3008653	RBS122
4	Electrode assembly	3007513	RBS108	20	Connector	3003602	RBS35
5	Electrode bracket	3006552	RBS29	21	Flexible pipe	3007672	RBS36
6	Nozzle holder	3008642	RBS111	22	Tube	3008644	RBS113
7	Collar	3008643	RBS112	23	Pressure gauge connector	3008876	RBS138
8	High voltage lead	3008794	RBS129	24	Drive coupling	3000443	RBS16
9	Air damper assembly	3008647	RBS116	25	Solenoid	3008648	RBS117
10	Fan - 15/21	3005788	RBS151	26	Motor RBS102	3002836	RBS102
10	Fan - 15/26	3005708	RBS39	27	Cover	3008649	RBS118
10	Fan - 26/35	3008645	RBS142	28	Control box assembly	3008652	RBS103
11	Photocell	3008646	RBS115	29	Solenoid lead	3008851	RBS139
12	Capacitor 4.5 µF	3002837	RBS149	30	Cover	3008879	RBS141
13	Seal kit	3008878	RBS140	31	Air tube spigot	3062774	RBS143
14	Needle valve	3007582	RBS109				

14 - HEALTH AND SAFETY INFORMATION

Under the Consumer Protection Act 1987 and Section 6 of the Health & Safety at Work Act 1974, we are required to provide information on substances hazardous to health (COSHH Regulations 1988).

Adhesives, sealants and paints used in the manufacture of the product are cured and present no known hazards when used in the manner for which they are intended.

The following other materials are present in the product:

Insulation materials

Material Types: Ceramic fibre board, mineral wool.

Description: Rigid board, slabs, sleeves, gaskets, ropes.

Known Hazards: May cause temporary irritation or rash to skin. High dust levels may irritate eyes and upper respiratory system.

Precautions: Avoid unnecessary or rough handling, or harsh abrasion of boards. Normal handling and use of material should not produce high dust levels.
Avoid inhalation, and contact with skin and eyes.
After handling always follow normal good hygiene practices.

Protection: Use disposable gloves, face mask and eye protection.

First Aid: Eyes - If irritation occurs, wash eyes with copious amounts of water. If symptoms persist, seek immediate medical advice.
Skin - If irritation occurs, wash under running water before washing with soap and water.
Inhalation - Remove to fresh air, drink water to clear throat and blow nose to remove dust/fibres.
Ingestion - Drink plenty of water.

Sealants

Material Types: Silicone elastomer.

Description: Sealant and adhesive.

Known Hazards: Irritation to eyes.

Precautions: Avoid inhalation of vapour, contact with eyes and prolonged or repeated contact with skin.
After handling always follow normal good hygiene practices.

Protection: Use eye protection. Rubber or plastic gloves should be worn where repeated contact occurs and a face mask worn when working in confined spaces.

First Aid: Eyes - Flush eyes with water for 15 minutes. Seek immediate medical attention.
Skin - Wipe off and wash with soap and water.
Inhalation - Remove to fresh air.

Kerosene and Gas oil fuels (Mineral oils)

Known Hazards: The effect of mineral oils on the skin vary according to the duration of exposure and the type of oil. The lighter fractions remove the protective grease naturally present on the skin, leaving it dry, liable to crack and more prone to damage by cuts, abrasions and irritant chemicals.
Skin rashes (Oil acne) most often on arms, but also on any part of the body in contact with oil or oily clothing.
Contact with fuel oils can cause dermatitis.

Precautions: Avoid as far as possible any skin contact with mineral oil or with clothing contaminated with mineral oil.
The use of a lanolin-based barrier cream is recommended, in conjunction with regular washing with soap and rinsing with water to ensure all oil is removed from the skin.
Take care to prevent clothing, especially underwear, from becoming contaminated with oil.
Do not put oily rags or tools in pockets, especially trouser pockets.
Have first-aid treatment at once for an injury, however slight.
Do not inhale any vapours from mineral oils.

15 - EC DECLARATION OF CONFORMITY

We declare that the Grant Vortex range of Oil Boilers equipped with Riello RDB burners approved to EN 267: 1991 satisfy the requirements of the following European Directives:-

1. 89/336/EEC - Electromagnetic Compatibility Directive
Referred to the generic standards EN 55014: 1993, EN 50082: 1: 1992
2. 73/23/EEC - Electrical Equipment Safety Regulations Directive
Referred to the generic standard NO: 3260: The Electrical Equipment (Safety) Regulations: 1994
3. 92/42/EEC - Hot Water Boiler Efficiency Directive
Referred to the generic standard The Boiler (Efficiency) (Amendment) Regulations 1994 (SI 1994/3083)







Complies with the EC Low voltage,
Electromagnetic compatibility and
Boiler efficiency Directives



89/336/EEC
73/23/EEC
92/42/EEC

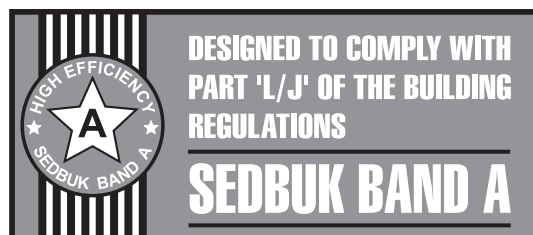

Grant Engineering (UK) Limited

Hopton House, Hopton Industrial Estate, Devizes, Wiltshire SN10 2EU

Telephone: (01380) 736920 Fax: (01380) 736991

email: info@grantuk.com website: www.grantuk.com

This manual is accurate at the date of printing but will be superseded and should be disregarded if specifications and/or appearances are changed in the interests of continued product improvement.

All goods sold are subject to our official Conditions of Sale, a copy of which may be obtained on application.

© Grant Engineering (UK) Limited 2008. No part of this manual may be reproduced by any means without prior written consent.