



Part No.DOC.29 Rev.01 July 2008

Supplementary User & Installation Instructions

Vortex Pro External Combi 21e, 26e & 36e

IMPORTANT

These Supplementary Instructions **MUST** be read in conjunction with the main User, Installation & Servicing Instructions supplied with the boiler.

1. USER INSTRUCTIONS

Please note that these User instructions REPLACE those given in Section 1 of the main instruction manual supplied with the boiler.

1.1 About your Vortex Pro External Combi boiler

Your Grant Vortex Pro Combi boiler is fully automatic and when the boiler On/off switch is set to ON, will provide domestic hot water at mains pressure on demand and central heating when the hot water and heating system controls call for it.

Your boiler may be fitted with one of the following control options, located in a convenient position remote from the boiler:

- Option A Programmable room thermostat only
- Option B Timer and room thermostat
- Option C 2-channel programmer and room thermostat

Whatever type of control is connected to your boiler, it will allow you to set the operating times of your central heating.

In the case of options A and B, domestic hot water is available continuously, providing the boiler is switched on, irrespective of the heating control settings. In the case of option C, you can set the operating times for both heating and hot water using the heating and hot water settings respectively on the programmer.

IMPORTANT. The boiler will produce a limited amount of hot water during the 'off' Hot Water periods set on the programmer. Refer to 'Night time' hot water operation – Section 1.7.

Heating operation

The boiler will only provide central heating when either the Programmer or Timer is in a 'heating 'on' period and the room thermostat is 'calling' for heat. When the Programmer or Timer is set to 'off', the boiler will not provide central heating at all.

For Summer time operation, when central heating is not required, set the Heating channel of the programmer (or the Heating Timer) to 'off'.

Hot Water operation

If either a Programmable Room Thermostat or Heating Timer with Room Thermostat is connected to the boiler (as Options A or B in section 1.1) there is no timed control for the hot water operation of the boiler and it will provide hot water continuously on demand, irrespective of any Timer settings.

If a Programmer with Room thermostat is connected to the boiler (as Option C in section 1.1) the boiler will only provide hot water during the 'on' periods set on the programmer.

'Night time' hot water function – refer to Section 1.7 of these Supplementary Instructions.

1.2 Boiler controls (see Fig. 1)

To access the controls, remove the front panel by turning the handle at the bottom anticlockwise and pull it forward at the bottom.

- 1 **Boiler On/Off switch** – This switches the boiler on and off. The boiler On/Off switch incorporates a 'mains on' neon; see Fig.1, which lights when the boiler is switched on. Please note that the 'mains on' neon does not necessarily indicate that the burner is firing.
NB. When the On/Off switch is set to 'ON' the POWER indicator on the control panel will light.
IMPORTANT: Please note that the boiler will not supply central heating or domestic hot water if this switch is set to 'OFF', and also the built in frost thermostat will not operate.
- 2 **Service switch** – This switch enables the Service Engineer to temporarily override the remote heating/hot water controls (timer, room thermostat or programmer) to operate the boiler for servicing purposes. This is a 'momentary' or non-latching switch that cannot be left set to ON. The boiler will automatically revert to normal operation when 15 minutes have elapsed since it was last operated.
- 3 **Boiler indicator lights** – These 8 red lights indicate the operating situation of the boiler.
- 4 **Boiler (heating) thermostat** – Controls the temperature of the water leaving the boiler to the central heating system. Operation of this control does **not** affect the temperature of the hot water flowing to the taps.

The temperature of the water leaving the boiler to the radiators can be increased by turning the boiler (heating) thermostat clockwise.

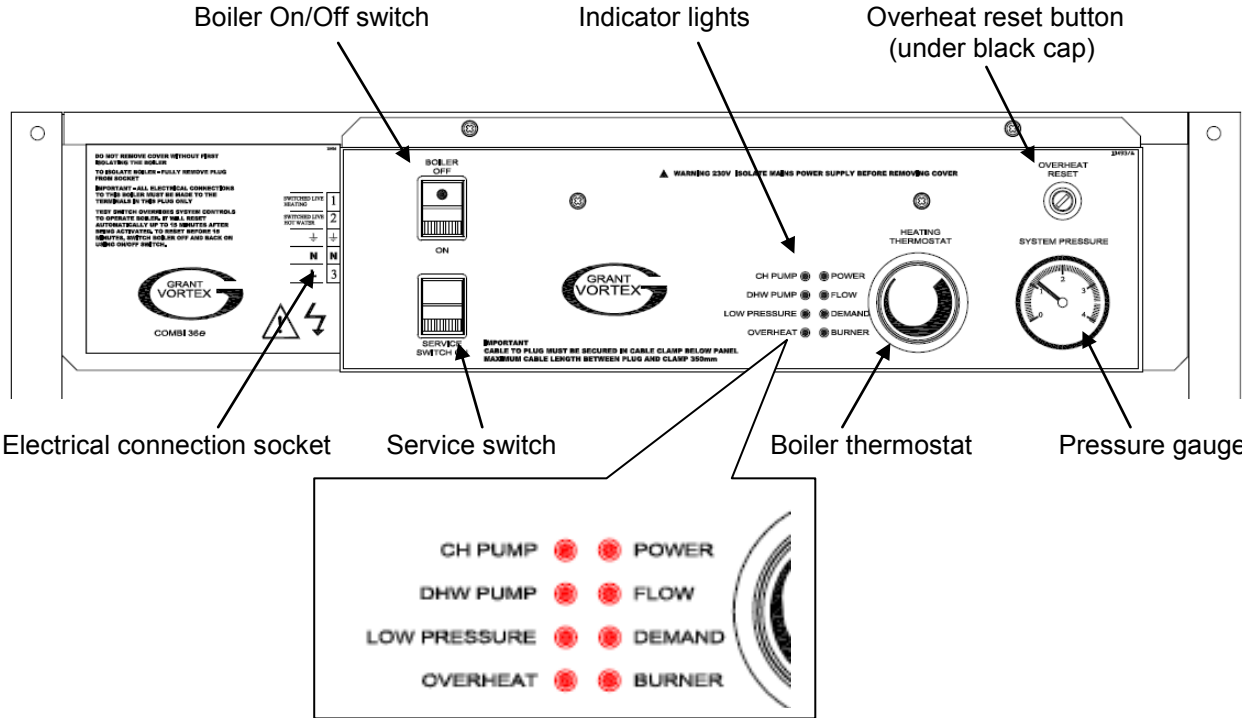

Fig. 1 – Vortex Pro External Combi control panel

1.3 About your fuel

Grant Vortex Pro Combi boilers only operate on Class C2 Kerosene to BS2869:1998. You should always quote the type of fuel you require when ordering from your supplier.

Do not wait until the fuel runs out before you order some more. Sludge in the bottom of the tank may be drawn into the fuel lines. If it is possible, switch off the boiler when the new supply is delivered and leave the fuel to settle for an hour before restarting the boiler.

1.4 Lighting your boiler (Refer to Fig. 1)

- 1 Before lighting your boiler, ensure that
 - There is sufficient fuel in the supply tank
 - All fuel supply valves are open
 - The water supply is on
 - The electricity supply to the boiler is off
 - The Boiler On/Off switch is set to OFF
 - The White pointer on the pressure gauge is not below the red pointer
 - The room thermostat is at the desired setting
 - The timer or programmer is correctly set
- 2 Switch on the electricity supply to the boiler.
- 3 Set the On/Off switch to ON.
- 4 The boiler will light automatically to heat the water stored in the boiler. If the Programmer or Timer is set to a 'heating 'on' period and the room thermostat is 'calling' for heat, the boiler will continue to run to provide central heating, after the store reaches temperature.
- 5 Once the store has reached temperature, if a hot tap is opened the boiler will supply hot water.

1.5 Turning off your boiler (Refer to Fig. 1)

For short periods – Set the On/Off switch to OFF.

To re-start the boiler, simply set the switch to ON.

For long periods – Set the On/Off switch to OFF and switch of the electricity supply to the boiler. If required, the fuel supply valve may be closed and the water and electrical supplies turned off at the mains. To re-start the boiler, refer to the full lighting instructions above.

1.6 Points to check if the boiler fails to light

- 1 Ensure that a fuse has not blown or that the electricity supply has not failed.
- 2 Check that the boiler On/Off switch is set to ON and that the POWER indicator on the control panel is lit.
- 3 Check that the timer or programmer is working and is in an 'on' period.
- 4 Check that all thermostats are set to the desired setting and are 'calling' for heat.
- 5 Check the DEMAND indicator on the control panel is lit.
- 6 Check if the burner 'Lock-out' reset button (on the front face of the burner) is lit.
- 7 If it is, press in the button to start the burner. If the burner fails to light and goes to 'Lock-out' again, check that you have sufficient fuel in the storage tank and the fuel supply valves are open.
- 8 Check that remote fire valve has not 'tripped'. Reset if necessary.
- 9 Check to see if the overheat thermostat has operated. Refer to note 4 – Section 1.9.

- 10 Check the heating system water pressure. If it falls below 0.2 bar the boiler low pressure cut-out will be activated, cutting power to the burner, and the red 'LOW PRESSURE' indicator on the control panel (see Fig. 1) will flash. The system must be re-charged to between 0.5 and 1 bar. If the heating system loses pressure on a regular basis then contact your Installer to investigate the cause.
- 11 If the burner still fails to light after carrying out these checks then a fault exists. Switch off the electricity supply to the boiler and contact your service engineer.

1.7 Domestic hot water system

The boiler will supply domestic hot water whenever a hot tap is opened, provided the boiler On/Off switch is set to ON. If a 2-channel programmer is fitted, the Hot water setting on the programmer must be 'on' for the boiler to provide continuous hot water.

'Night time' hot water function

This is a feature built in to your boiler allowing a limited amount of hot water to be drawn off during periods when either the hot water programmer channel is 'off' (e.g. during the night). When a hot tap is opened during this period, the flow switch activates the hot water store pump and the incoming mains cold water is heated using whatever heat is present in the primary store. The burner will not fire and so the heat in the store will gradually be used up and the hot water temperature will reduce with time.

PLEASE NOTE: The flow of water from the taps (hot or cold) depends on the mains pressure, and in some homes it may not be possible to use more than one tap at a time.

1.8 Sealed central heating system

The boiler operates on a sealed heating system. Your installer will have pressurised the system and set the red pointer on the pressure gauge (see Fig. 1) to indicate a system pressure (when cold) of usually between 0.5 and 1.0 bar. **Do not** adjust this pointer.

The white pointer indicates the actual system pressure which will increase slightly when the boiler is operating. If the white pointer falls below the red pointer (when the boiler is switched off and cold), you should contact your Installer to check the heating system for leaks.

If the heating system water pressure falls below 0.2 bar the boiler low pressure cut-out will be activated, cutting power to the burner, and the red 'LOW PRESSURE' indicator on the control panel (see Fig. 1) will flash. The system must be re-charged to between 0.5 and 1 bar. If the heating system loses pressure on a regular basis then contact your Installer to investigate and rectify the cause.

The boiler is fitted with an automatic air vent which removes air trapped in the boiler. Any air trapped in the radiators needs to be removed by venting the radiators via the vent screw at the top of each radiator. Only vent a radiator if the top is cool when the bottom is hot. Venting will reduce the system pressure, as indicated on the pressure gauge, so only vent when necessary and check the system pressure as mentioned above.

NB. Your sealed system may incorporate a 'Top-up' vessel. Advice on how to use this should be obtained from your installer.

The boiler is fitted with a safety (or pressure relief) valve to automatically release excess pressure from the system. If the water or steam is emitted from the end of the safety valve discharge pipe, switch off the boiler and contact your Installer or Service Engineer.

The Expansion vessel air charge must be checked annually. Failure to maintain an adequate air charge in the vessel may invalidate the warranty.

To re-pressurise the system by adding water:

- 1 Only add water to the system when it is cold and the boiler is switched off. Do not overfill.
- 2 Ensure the flexible filling loop is connected and that the shut off valve connecting it to the boiler is open and the double check valve at the front is closed. A valve is open when the operating lever is in line with the valve, and closed when it is at right angles to it.

- 3 Gradually open the double check valve on the front of the filling loop until the water is heard to flow.
- 4 Vent each radiator in turn, starting with the lowest one in the system, to remove air.
- 5 Continue to fill the system until the pressure gauge indicates the required pressure between 0.5 and 1.0 bar. Close the fill point valve.
- 6 Close the valves either side of the filling loop and disconnect the loop.

1.9 General notes and care of your system

- 1 **Boiler controls** – Refer to Section 1.2.
- 2 **Pressure switch** – If the heating system water pressure falls below 0.2 bar the boiler pressure cut-out switch will activate and the red 'LOW PRESSURE' indicator on the control panel (see Fig. 1) will flash. The system must be recharged to between 0.5 to 1bar. If the heating system loses pressure on a regular basis then contact your Installer to investigate the cause.
- 3 **Burner Lock-out reset button** – If there is a burner malfunction, a built-in safety circuit switches the burner off and the 'Lock-out' reset button on the burner will light. Usually such malfunctions are short lived and pressing the reset button will restore normal operation. The reset button should not be pressed more than twice in attempting to start the burner. If the burner continually goes to 'Lock-out' a fault exists **or** the fuel supply is low. If you have checked that you have sufficient fuel, you will need to call your Service engineer.
- 4 **Overheat thermostat** –Your boiler is fitted with a safety overheat thermostat which will automatically switch off the boiler in the case of a control malfunction causing overheating. The red 'OVERHEAT' indicator on the control panel (see Fig.1) will flash indicating the overheat thermostat has operated.

If your boiler goes off and you try to light it but nothing happens, and the 'Lock-out' reset button on the burner is not lit, the overheat thermostat has probably operated. The boiler will not light until the thermostat is reset. To reset, unscrew the small plastic cap (see Fig.1), and press the button and the 'OVERHEAT' indicator should go off. Replace the plastic cap.

Note: You may have to wait for the boiler to cool down before the button will reset. If this condition repeats, contact your Service engineer.

IMPORTANT: Check the system pressure and re-pressurise as necessary before attempting to reset the overheat thermostat. Refer to Section 1.8 for details on re-pressurising system.

- 5 **Ventilation** – Always ensure that the boiler ventilation openings in the front panel are **not** obstructed at any time. Periodically check that they are clear. **Do not** attempt to 'box in' the boiler or build an enclosure around it.
- 6 **Flue terminal** – The flue terminal **must not** be obstructed or damaged. In severe conditions check that the terminal does not become blocked with snow. **Do not** place any combustible material on or around the boiler or flue terminal.
- 7 **Frost Protection** – Your boiler is fitted with a pre-set internal frost protection thermostat. Should either the air temperature around the boiler, or the water temperature within the boiler, fall to below 5°C then this thermostat will be activated. The boiler will then operate briefly to prevent it from freezing. If you are intending to be away for a long period, the boiler and system should be drained. Contact your Service engineer for draining and filling the system.
- 8 **Cleaning and servicing** – Lightly wipe over the case with a damp cloth and a little detergent. **Do not** use abrasive pads or cleaners. You should have your boiler serviced at least once a year to ensure safe and efficient operation. Contact your Service engineer for further details.
- 9 **Failure of electricity supply** - If the electricity supply fails, the boiler will not operate. It should relight automatically when the supply is restored.

Note: The time and on/off settings on a 7-day or 24-hour timer or a 2-channel programmer may need to be reset after a power failure.

1.10 Electricity supply

The boiler requires a 230/240 V – 50 Hz supply. It must be protected by a 5 Amp fuse.

Warning: This appliance must be earthed

1.11 Access for servicing

The Vortex Outdoor Combi 36e requires adequate access to both the front and back of the boiler enclosure as well as clearance for removal of the top panel for servicing.

2. INSTALLATION - ELECTRICAL CONNECTION

Please note that the following REPLACES Sections 6.6, 6.7, 6.8 and 6.9 in the main instruction manual supplied with the boiler.

Important: ensure that the electrical supply has been isolated before making any connections to the boiler.

Note: A Service switch is fitted to the control panel to allow the Service Engineer to test-fire the boiler. When set to 'ON' the switch temporarily by-passes the external control system to operate the boiler.

This is a 'momentary' or non-latching switch that cannot be left set to ON. The boiler will automatically revert to normal operation when 15 minutes have elapsed since it was last operated. If required, this 15 minute override period can be stopped by switching the boiler On/Off switch OFF and then back to ON. The boiler will then operate as normal under control of the external heating/hot water controls (timer, room thermostat or programmer).

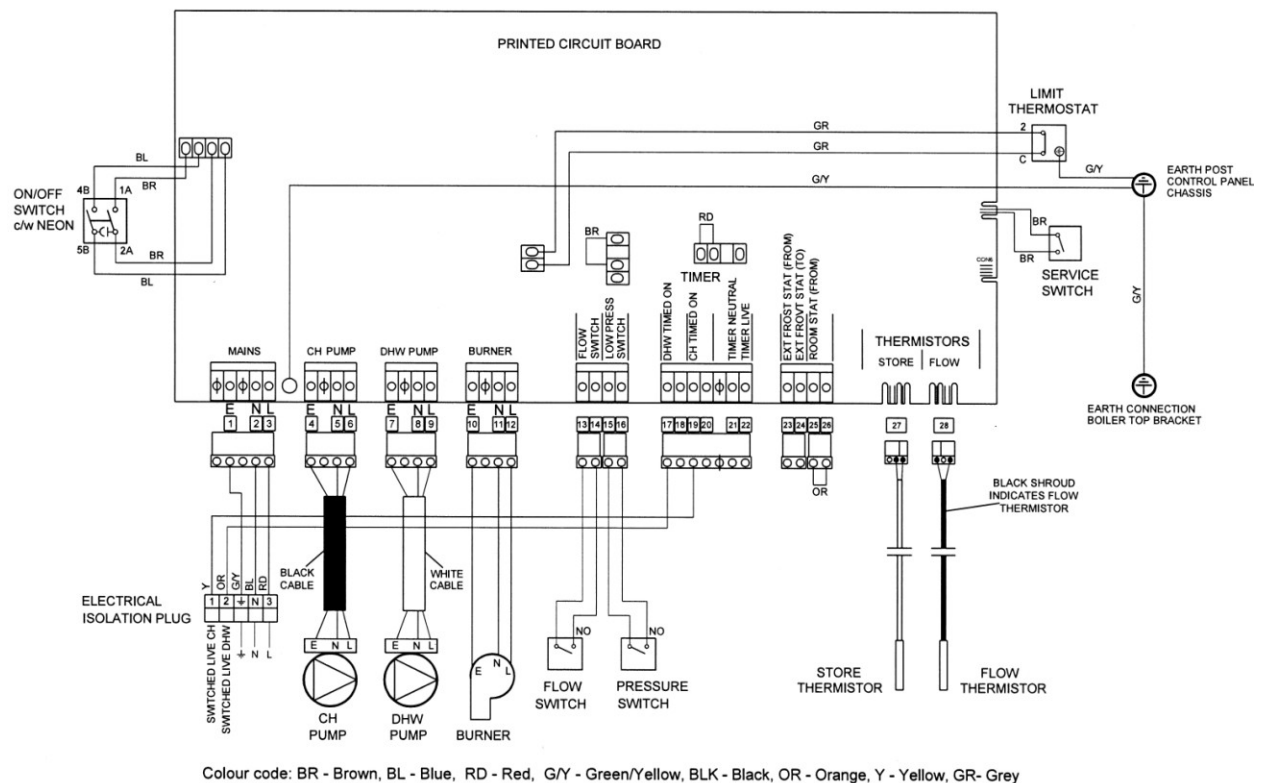

Fig.2. Boiler wiring diagram

2.1 Connection of the power supply

The boiler requires a permanent 230 V mains supply (fused at 5 Amp).

The Vortex Combi 36e is supplied fitted with an electrical isolation plug - located in the left hand end of the boiler control panel. All electrical wiring to the boiler **must** be made to this plug, as follows:

- 1 The isolation plug is located at the left hand end of the control panel. Pull the plug to the left to remove it from the socket in the control panel.
 - 2 Prise open the clips on either side of the plug and open the top to access the five terminals.
IMPORTANT: Pass the cable from the electrical power supply and heating/hot water controls through the cable clamp on the underside of the control panel **before** making connections to the isolating plug.
 - 3 Connect the electrical supply and heating/hot water controls to the terminals in the isolating plug as follows:
 - Terminal 1 – Heating on (from Timer, Thermostat or Programmer)
 - Terminal 2 – Hot water on (from Programmer)
 - Earth Terminal – Green/Yellow to mains Earth
 - Terminal N – Blue to mains Neutral
 - Terminal 3 – Brown to mains Live (including permanent live for Frost Thermostat)
- Note:** The terminal numbers are marked on the top cover of the plug.
- 4 Replace the cover on the plug ensuring it is securely fitted. Measure a maximum of 350 mm of cable between the plug and the cable clamp below the control panel and tighten the cable clamp to secure the cable.

IMPORTANT: Check that the cable is securely clamped and that the cable length between the clamp and plug is no more than 350 mm.
 - 5 Re-fit the isolating plug into the socket in the control panel.
Do not switch on the electricity supply at this stage.

2.2 Connect the Controls

To control the central heating on/off periods only (and not the domestic hot water), it is recommended that the boiler be wired to either a single channel timer and room thermostat, or the Grant programmable room thermostat (Ref. RSKIT), sited at a convenient location within the property. NB. Full installation and User instructions are provided with the Grant Programmable Room thermostat.

The switched live from these central heating controls must be connected to Terminal 1 on the electrical isolation plug. Refer to Fig.3 or Fig.4 for connection details.

Note: When connected in this way, a link **must** be fitted between terminals 2 and 3 - to enable the boiler to operate for hot water.

2.3 Connection of a two-channel Programmer

Alternatively, if control over hot water operation of the boiler is required for the Outdoor Vortex Combi 36e use the Grant two-channel programmer (ref. ESKIT).

Important: If an alternative two-channel programmer to the Grant ESKIT is to be used, it must be suitable for 230 V and internally linked.

Refer to Fig.5 for connection details. Connections from the programmer are as follows:

- Switched Live heating to terminal 1 on boiler plug
- Switched Live hot water to terminal 2 on boiler plug
- Mains Earth to terminal on boiler plug
- Mains Neutral to terminal N on boiler plug
- Permanent Live frost stat to terminal 3 on boiler plug

Note: If a two-channel programmer is used with the Outdoor Vortex Combi 36e, the User **must** be made aware that if the hot water channel is left in the OFF position, hot water may not be available on demand and that the primary store may need to recover before any hot water is available.

WIRING DIAGRAMS

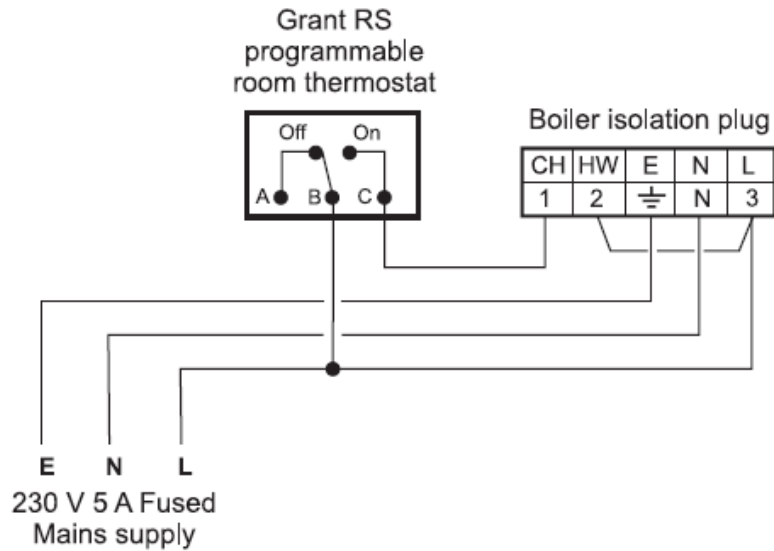

Fig.3. Connection for Programmable Room Thermostat (RSKIT)

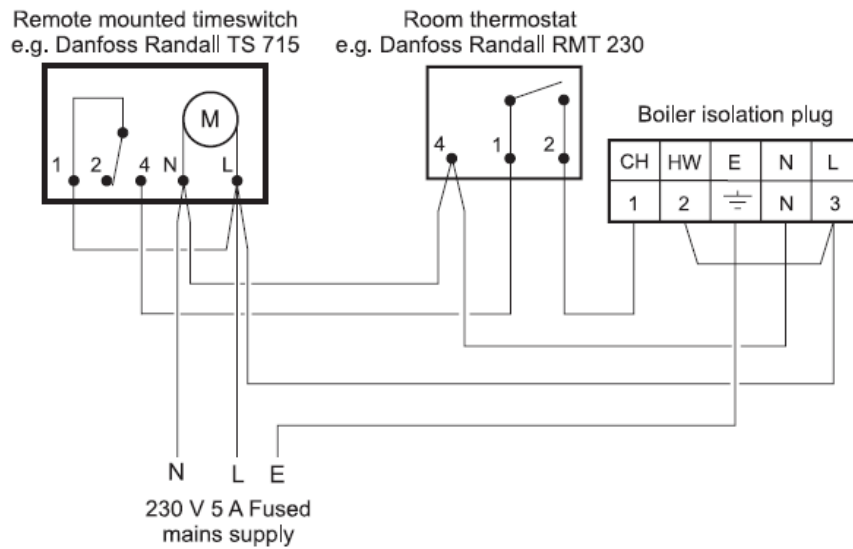

Fig.4. Connections for Timer and Room Thermostat

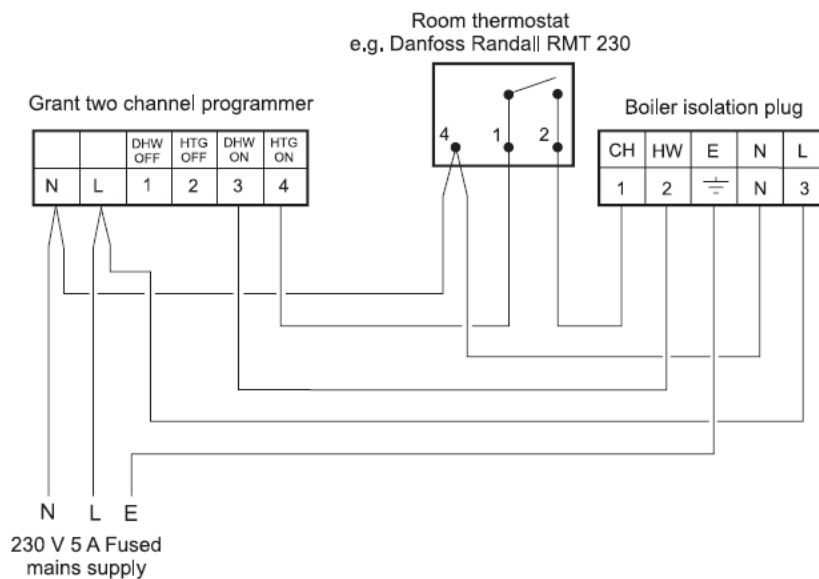

Fig.5. Connections for Grant 2-channel Programmer (ESKIT) and Room Thermostat

3. FAULT FINDING

3.1 Initial Check List - for Installer or Service Engineer.

If boiler fails to light – first follow the procedure given in Section 1.6 of this supplement.

If burner still fails to light – follow the procedure given below. Some faults can be identified by checking the indicator lights on the control panel. Refer to Fig.1

For Hot Water - the following indicator lights must be lit:

POWER	
DHW PUMP	If flashing this indicates a Store thermistor or PCB fault (see below).
FLOW	If not lit this indicates possible flow switch problem.
DEMAND	
BURNER	If flashing this indicates PCB fault (see below).

Note: There may be a delay before the BURNER indicator is lit when the store is up to temperature.

If the above indicator lights are lit this indicates that voltage is being supplied to the relative component. For further guidance refer to the main fault finding procedure.

Note: For 'Night time' Hot Water function (refer to section 1.7 of this supplement) - the following indicator lights must be lit:

POWER	
DHW PUMP	If flashing this indicates a Store thermistor or PCB fault (see below).
FLOW	If not lit this indicates possible flow switch problem.
DEMAND	

For Central Heating - the following indicator lights must be lit:

POWER	
CH PUMP	If flashing this indicates Boiler flow thermistor or PCB fault (see below).
	Note: The DHW PUMP indicator may be lit if the boiler is operating to heat the store – which has priority over the CH operation.
DEMAND	
BURNER	If flashing this indicates PCB fault (see below).

Note: There may be a delay before the BURNER indicator is lit when the boiler is up to temperature.

As above, for further guidance refer to the main fault finding procedure.

3.2 Main Fault finding procedure

3.2.1 If Hot Water is working but not Central Heating – follow the procedure below:

First, set 'Hot Water' channel of the programmer (if fitted) to 'off'.

If no programmer is fitted – isolate all electrical supplies to boiler, remove link from between terminals 2 & 3 in boiler isolation plug (refer to Fig. 2 or Fig.3) then re-connect electrical supply to continue check. Link must be replaced on completion of fault finding.

Is the 'DEMAND' indicator lit?

YES Continue to next check

NO Check programmer/timer and room thermostat are calling for heating
Note: If store is at temperature the 'DEMAND' indicator will NOT be lit.

Is the 'FLOW SWITCH' indicator lit with no hot tap operating?

YES Check flow switch

Is it correctly positioned - arrow must point in direction of flow.

Is it free to operate - close cold water isolation valve, remove flow switch from pipework body and manually operate switch when removed from the body.

Remove any blockage from flow switch.

NO Continue to next check.

Is the 'CH PUMP' indicator lit?

YES PCB is supplying voltage to the central heating circulating pump.

Check electrical connections at the pump.

Check for power at pump.

Check if CH pump is stuck. Remove pump Vent screw & check for rotation.

If stuck rotate shaft manually to restart.

If still not operating - replace the CH pump.

NOTE: A 6metre head pump must be used.

If the CH pump is operating but no circulation

Check both pump valves are open

Check there are no air locks in the boiler/system

Check that pump impellor is attached to shaft.

Check CH check valve is fitted correctly – with arrow in direction of flow.

NO Is the 'CH PUMP' indicator is flashing

Fast flash (twice per second) indicates a fault with 'Flow' thermistor

Slow flash (once every two seconds) indicates a fault with the PCB (relay).

3.2.2 If Central Heating is working but not Hot Water – follow the procedure below:

First, set either the Heating Timer or the 'Heating' channel of the programmer (whichever is fitted) to 'off'.

Is the 'DEMAND' indicator lit?

YES Continue to next check

NO Check programmer is it calling for Hot Water and the 'Hot water' switch set to 'Timed'.

If no programmer fitted – check link is fitted between terminals 2 & 3 in the boiler isolation plug (refer to Fig. 2 or Fig.3).

Is the hot tap open with a flow of at least 3ltr/min?

YES Flow rate is sufficient to operate flow switch – continue to next check.

NO Open tap to achieve at least 3ltr/min flow.

If 3ltr/min cannot be achieved, check the following:

Are all the isolation valves open?

Is water pressure sufficient? Low water pressure = Low flow rate.

Minimum pressure 2 bar standing and 1 bar minimum operating.

Is the 'FLOW SWITCH' indicator lit?

YES The flow switch is activated – continue to next check.

NO Check flow switch

Is it correctly positioned - arrow must point in direction of flow.

Is it free to operate - close cold water isolation valve, remove flow switch from pipework body and manually operate switch to check.

Remove any blockage from flow switch.

Is there 230V and/or continuity at terminals 13 & 14 on PCB connector?

Is the 'DHW PUMP' indicator lit?

YES PCB is supplying voltage to the DHW store pump – continue to next check.

NO Is the 'DHW PUMP' indicator is flashing
Fast flash (twice per second) indicates a fault with 'Store' thermistor
Slow flash (once every two seconds) indicates a fault with the PCB (relay).

Is the DHW pump operating?

YES DHW pump is operating – continue to next check.

NO Check at pump
Check electrical connections at the pump.
Check for power at pump.
Check if DHW pump is stuck. Remove pump Vent screw & check for rotation.
If stuck rotate shaft manually to restart.
If still not operating - replace the DHW pump.

If the DHW pump is operating but no circulation
Check both pump valves are open
Check there are no air locks in the boiler/system*
Check that pump impellor is attached to shaft.
Check DHW check valve is fitted correctly – with arrow in direction of flow.
Note: A 6metre head pump must be used and set to max speed.

***If boiler/system is air locked**

Check system pressure it should be approx 1bar. Re-charge if required.
Check both auto air vents are open.
Check for air in pump head (remove vent screw)
Check for air on return pipework by venting the manual air vent.
Check the vent nut on both of the non-return valves. Refer to venting procedure supplied with boiler.

If the system still appears to be air locked the following procedure can be used:

Increase the system pressure to 2 bar
Clear air lock by "shunting" the 2 circulating pumps - turn the DHW pump On and then Off and then immediately turn the CH pump On, repeating this cycle to remove the air.
Once system is operational, reduce the system pressure back to 1bar.

Is the burner operating?

YES The boiler should now produce hot water.

NO Continue to next check.

Is the 'BURNER' indicator lit?

YES PCB is supplying voltage to burner.
Refer to Burner Fault Finding. Refer to page 58 in main manual supplied with the boiler.

NO Is the 'BURNER' indicator flashing - Slow flash (once every two seconds) indicates a fault with the PCB (relay).



Grant Engineering (UK) Ltd
Hopton House, Hopton Industrial Estate, Devizes, Wiltshire. SN10 2EU
Telephone 01380 736920 Fax 01380 736991
Email: sales @grantuk.com Website: www.grantuk.com